

H PARTS LIST

AIRTEK® Front Suspension System for Spartan Motorhome Chassis SOFTEK® Front Suspension System for Spartan Bus

LIT NO: SP-184

DATE: March 2020

REVISION: H

CONTENTS

DESCRIPTION	PAGE
AIRTEK® for Spartan Motorhome Chassis	
■ 12.4K Capacity – Equipped with STEERTEK™ NXT Axle equipped and Air Disc Brakes 12.4K	2
■ 13.5K • 14.6K Capacity – Equipped with STEERTEK NXT Axle and Air Disc Brakes	4
■ 10.5K • 12K • 12.6K • 14.6K Capacity – Equipped with STEERTEK Axle and Drum Brakes	8
SOFTEK® with STEERTEK Axle for Spartan Bus	
■ 10K Capacity – Equipped with Air Disc Brakes	12
■ 10K Capacity – Equipped with Drum Brakes	14
Tie Rod Selection Guide	7
Notes	7
Special Tool	11

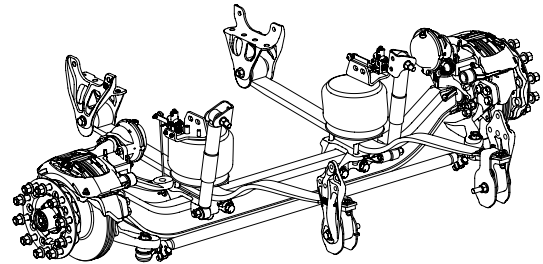

AIRTEK® with STEERTEK™ NXT Axle equipped with Air Disc Brakes

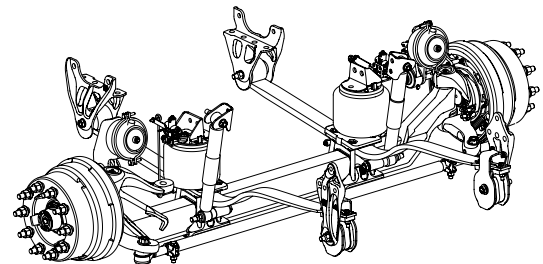

AIRTEK with STEERTEK Axle equipped with Drum Brakes

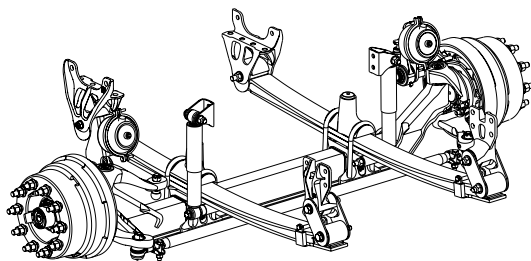

SOFTEK® with STEERTEK Axle equipped with Drum Brakes

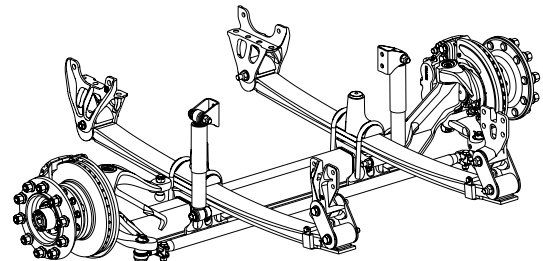

SOFTEK with STEERTEK Axle equipped with Air Disc Brakes



AIRTEK® with STEERTEK™ NXT axle built after May 2019

Equipped with Air Disc Brakes – 12.4K Capacity

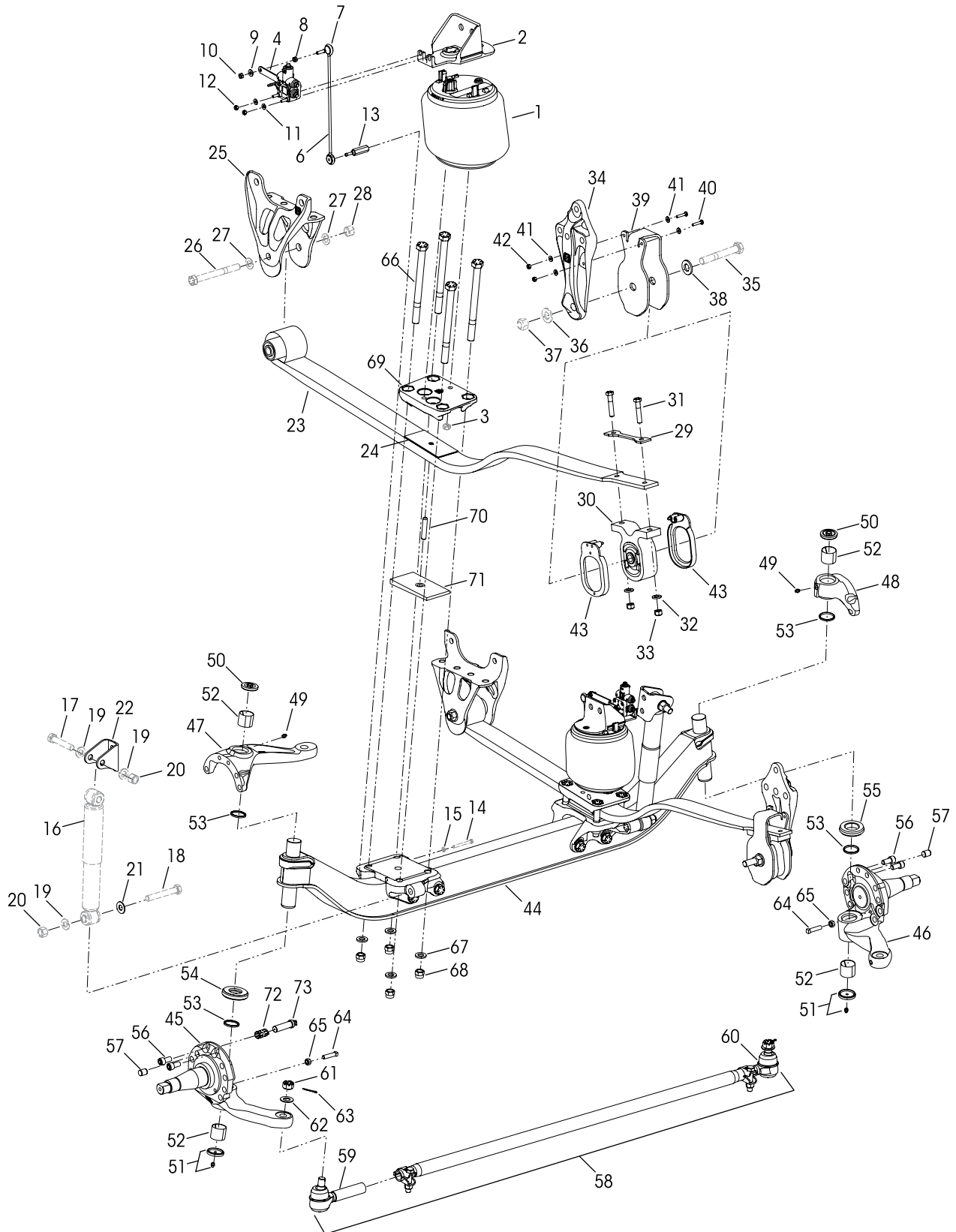

H AIRTEK® with STEERTEK™ NXT Axle for Spartan Motorhome Chassis equipped with Air Disc Brakes

VEHICLE				VEHICLE			
KEY NO.	PART NO.	DESCRIPTION	QTY.	KEY NO.	PART NO.	DESCRIPTION	QTY.
1	66349-002	Air Spring	2			Lower Steering Knuckle Assembly, Includes Key Nos. 52-53, 57	
2	60850-002	Upper Air Spring Bracket	2	45	58900-427	Left Hand	1
3		*1/2"-13 UNC Locknut	2	46	58900-428	Right Hand	1
		Height Control Valve & Linkage Assembly				Upper Steering Knuckle Assembly, Includes Key Nos. 52-53	
	66277-001	Left Hand, Includes Key Nos. 4, 6-12	1	47	60903-404	Left Hand	1
	66277-002	Right Hand, Includes Key Nos. 5-12	1	48	60904-402	Right Hand	1
		Height Control Valve				Kingpin Bushing and Bearing Service Kits	
4	66414-001	Left Hand	1		60961-628	Axle Set , Includes Kit Nos. 60961-629 & -630	
5	66414-002	Right Hand	1		60961-629	Left Hand with Composite Thrust Bearing , Includes Key Nos. 49-54, 56, Loctite	
6	59428-001	HCV Linkage - 335 mm	2		60961-630	Right Hand with Roller Thrust Bearing , Includes Key Nos. 49-53, 55-56, Loctite	
7	59169-000	5/16"-18 UNC Stud	2	49	33117-000	Grease Zerk	2
8	17491-011	5/16"-18 UNC Nut	2	50	68687-003	Grease Cap Assembly, Upper	2
9	22962-029	5/16" Hardened Washer	2	51	68687-002	Grease Cap Assembly, Lower	2
10	59016-000	5/16"-18 UNC Locknut	2	52	58909-001	Kingpin Bushing	4
11	22962-028	1/4" Hardened Washer	4			Thrust Bearing Service Kits	
12	49983-000	1/4"-20 UNC Locknut	4		60961-631	Axle Set , Includes Kit Nos. 60961-632 & -633	
13	59429-001	Lower Link Mount	2		60961-632	Left Hand Composite Thrust Bearing , Includes Key Nos. 53-54, 56, Loctite	
14		*3/8"-16 UNC x 3 1/2" Hex Bolt	2		60961-633	Right Hand Roller Thrust Bearing , Includes Key Nos. 53, 55-56, Loctite	
15		*3/8" Flat Washer	2	53	68731-000	Kingpin Seal	4
16		*Shock Absorber	2	54	59828-000	Left Hand Composite Thrust Bearing	1
17		*3/4"-10 UNC Upper Shock Bolt	2	55	64256-000L	Right Hand Roller Thrust Bearing	1
18		*3/4"-10 UNC Lower Shock Bolt	2	56	60236-001	5/8" Socket Head Cap Screw	4
19		*3/4" Hardened Washer	6	Not Shown	60937-000	Loctite® (Red) Compound Tube	1
20		*3/4"-10 UNC Hex Locknut	4	57	64246-000	ABS Sensor Sleeve	2
21	22962-046	Shock Spacer (Flat Washer) - 0.118" Thick	2	58		Tie Rod Assembly, Includes Key Nos. 59-61 <i>See Selection Guide on Page 7</i>	1
22	59423-002	Shock Bracket	2		60961-XXX	Tie Rod End Service Kits , <i>See Selection Guide on Page 7</i>	
		***Leaf Spring Assembly, Includes Key Nos. 23-24, 29-33, 43				Axle Set , Includes Left Hand & Right Hand Kits	
	82598-000	Left Hand	1			Left Hand , Includes Key Nos. 59, 61-63	
	82599-000	Right Hand	1			Right Hand , Includes Key Nos. 60-63	
23		**Leaf Spring with Spring Eye Bushing	2			Tie Rod Ends, Includes Key No. 61, <i>See Selection Guide on Page 7</i>	
24		**Galvanized Liner	2	59		Left Hand	1
25	64488-000	Front Hanger	2	60		Right Hand	1
26		*M20 Bolt	2	61		**7/8" Castle Nut	2
27		*M20 Washer	4	62	22962-007	7/8" Hardened Washer	2
28		*M20 Locknut	2	63	17800-004	Cotter Pin	2
	60961-002	Rear Spring Mount Service Kit, One Side , Includes Key Nos. 29-33			60961-069	Stop Bolt Service Kit, One Side , Includes Key Nos. 64-65	
29	58920-000	Spring End Plate	2	64	60238-001	1/2"-13 UNC Square Head Bolt	2
30	58918-000	Rear Spring Mount	2	65	60240-000	1/2"-13 UNC Hex Jam Nut	2
31	30970-011	1/2"-20 UNF x 2 1/4" Hex Bolt	4		34013-383	Clamp Group Fastener Kit, Axle Set , Includes Key Nos. 66-68	
32	22962-014	1/2" Hardened Washer	4	66	58917-001	3/4"-10 UNC x 4 1/4" Hex Bolt	8
33	17700-034	1/2"-20 UNF Nylon Locknut	4	67	22962-001	3/4" Hardened Washer	8
	59829-001	Rear Hanger Assembly, Includes Key Nos. 34, 38-42	2	68	17700-033	3/4"-10 UNC-2B Nylocknut	8
34	59825-000	Rear hanger	2	69	59826-000	Top Pad	2
35		*3/4"-10 UNC Hex Bolt	2	70	57159-004	1/2" Dowel Pin - 2.63"	2
36		*3/4" Flat Washer	2	71	68861-000	Caster Wedge	2
37		*3/4"-10 UNC Locknut	2	72	A-22930-4	ABS Sensor	2
	60961-016	Rear Hanger Clamp Service Kit, One Side , Includes Key Nos. 38-43		73	64550-000	ABS Sensor Clip	2
38	22962-033	3/4" Wide Washer	2			Air Disc Brake Assembly, <i>see Page 6 for Contents</i>	2
39	59830-001	Rear Hanger Clamp	2				
40	56935-001	1/4"-20 UNC x 1 1/4" Hex Bolt	4				
41	22962-028	1/4" Hardened Washer	8				
42	49983-000	1/4"-20 UNC Locknut	4				
43	59346-001	Thrust Washer	4				
	68977-008	STEERTEK NXT Axle Assembly , Includes Key Nos. 44-65	1				
44	68976-001M	Axle & Kingpin Assembly	1				



AIRTEK® with STEERTEK™ NXT axle built after May 2019
 Equipped with Air Disc Brakes – 13.5K • 14.6K Capacity

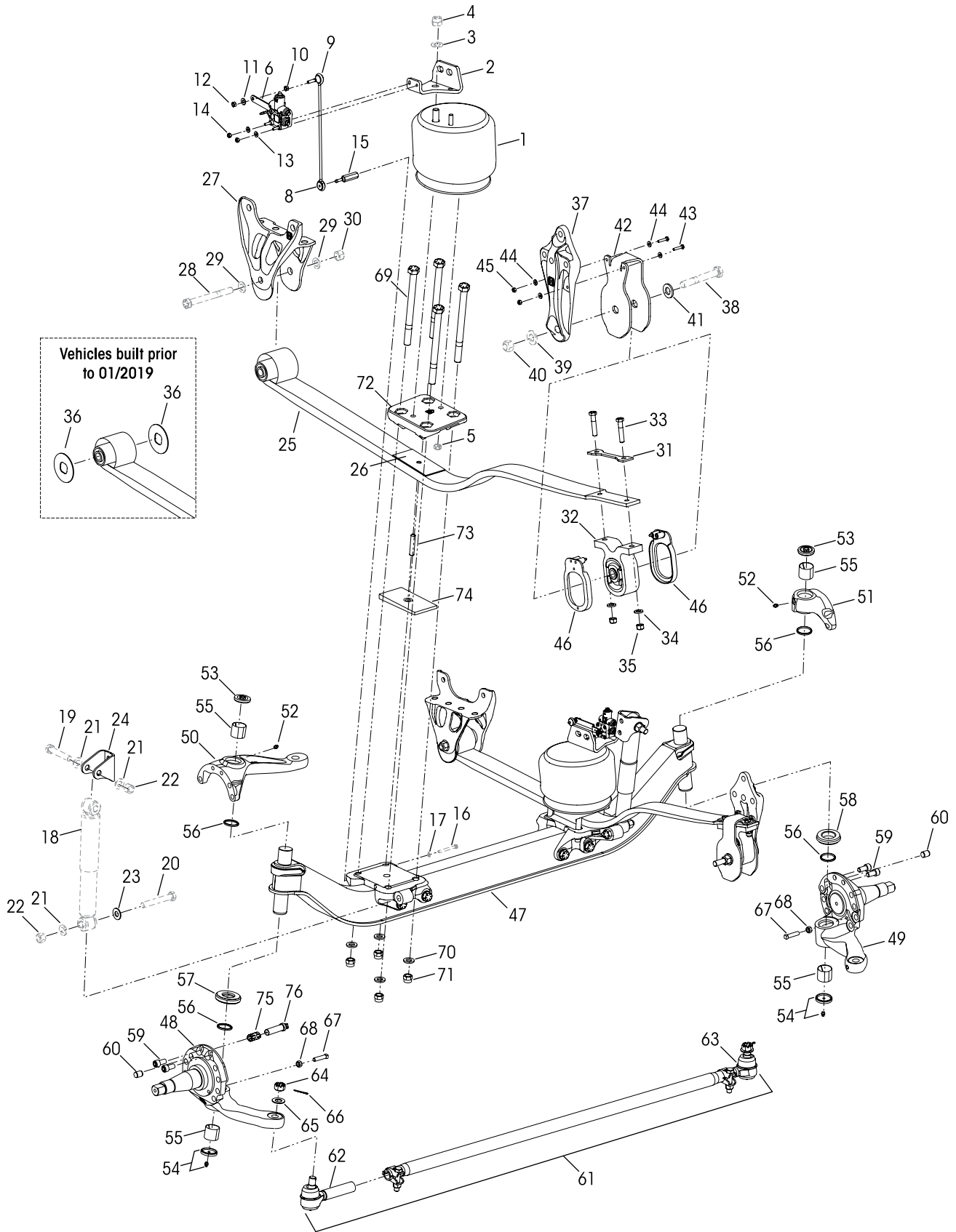

H AIRTEK® with STEERTEK™ NXT Axle for Spartan Motorhome Chassis equipped with Air Disc Brakes

VEHICLE				VEHICLE			
KEY NO.	PART NO.	DESCRIPTION	QTY.	KEY NO.	PART NO.	DESCRIPTION	QTY.
1	65790-002L	Air Spring	2	47		Axle & Kingpin Assembly	1
2	66140-000	Upper Air Spring Bracket	2		68966-005M	13.5K	
3		*3/4" Flat Washer	2		68976-002M	14.6K	
4		*3/4"-16 UNF Locknut	2			Lower Steering Knuckle Assembly, Includes Key Nos. 55-56, 60	
5		*1/2"-13 UNC Locknut	2	48	58900-427	Left Hand	1
	66277-005	Height Control Valve & Linkage Assembly Left Hand, Includes Key Nos. 6, 8-14	1	49	58900-428	Right Hand	1
	66277-006	Right Hand, Includes Key Nos. 7-14	1			Upper Steering Knuckle Assembly, Includes Key Nos. 55-56	
6	66414-001	Height Control Valve Left Hand	1	50	60903-404	Left Hand	1
7	66414-002	Right Hand	1	51	60904-402	Right Hand	1
8	59428-013	HCV Linkage - 352 mm	2			Kingpin Bushing and Bearing Service Kits	
9	59169-000	5/16"-18 UNC Stud	2		60961-628	Axle Set , Includes Kit Nos. 60961-629 & -630	
10	17491-011	5/16"-18 UNC Nut	2		60961-629	Left Hand with Composite Thrust Bearing , Includes Key Nos. 52-57, 59, Loctite	
11	22962-029	5/16" Hardened Washer	2		60961-630	Right Hand with Roller Thrust Bearing , Includes Key Nos. 52-56, 58-59, Loctite	
12	59016-000	5/16"-18 UNC Locknut	2	52	33117-000	Grease Zerk	2
13	22962-028	1/4" Hardened Washer	4	53	68687-003	Grease Cap Assembly, Upper	2
14	49983-000	1/4"-20 UNC Locknut	4	54	68687-002	Grease Cap Assembly, Lower	2
15	59429-001	Lower Link Mount	2	55	58909-001	Kingpin Bushing	4
16		*3/8"-16 UNC x 3 1/2" Hex Bolt	2			Thrust Bearing Service Kits	
17		*3/8" Flat Washer	2		60961-631	Axle Set , Includes Kit Nos. 60961-632 & -633	
18		*Shock Absorber	2		60961-632	Left Hand Composite Thrust Bearing , Includes Key Nos. 56-57, 59, Loctite	
19		*3/4"-10 UNC Upper Shock Bolt	2		60961-633	Right Hand Roller Thrust Bearing , Includes Key Nos. 56, 58-59, Loctite	
20		*3/4"-10 UNC Lower Shock Bolt	2	56	68731-000	Kingpin Seal	4
21		*3/4" Hardened Washer	6	57	59828-000	Left Hand Composite Thrust Bearing	1
22		*3/4"-10 UNC Hex Locknut	4	58	64256-000L	Right Hand Roller Thrust Bearing	1
23	22962-046	Shock Spacer (Flat Washer) - 0.118" Thick	2	59	60236-001	5/8" Socket Head Cap Screw	4
24	59423-002	Shock Bracket	2	Not Shown	60937-000	Loctite® (Red) Compound Tube	1
		***Leaf Spring Assembly, Includes Key Nos. 25-26, 31-35, 46		60	64246-000	ABS Sensor Sleeve	2
	82598-000	Left Hand, <i>replaces 59930-031</i>	1	61		Tie Rod Assembly, Includes Key Nos. 62-64 <i>See Selection Guide on Page 7</i>	1
	82599-000	Right Hand, <i>replaces 59930-032</i>	1		60961-XXX	Tie Rod End Service Kits , <i>See Selection Guide on Page 7</i>	
25		**Leaf Spring with Spring Eye Bushing	2			Axle Set , Includes Left Hand & Right Hand Kits	
26		**Galvanized Liner	2			Left Hand , Includes Key Nos. 62, 64-66	
27	64488-000	Front Hanger	2			Right Hand , Includes Key Nos. 63-66	
28		*M20 Bolt	2			Tie Rod Ends, Includes Key No. 64, <i>See Selection Guide on Page 7</i>	
29		*M20 Washer	4	62		Left Hand	1
30		*M20 Locknut	2	63		Right Hand	1
	60961-002	Rear Spring Mount Service Kit, One Side , Includes Key Nos. 32-36		64		**7/8" Castle Nut	2
31	58920-000	Spring End Plate	2	65	22962-007	7/8" Hardened Washer	2
32	58918-000	Rear Spring Mount	2	66	17800-004	Cotter Pin	2
33	30970-011	1/2"-20 UNF x 2 1/4" Hex Bolt	4		60961-069	Stop Bolt Service Kit, One Side , Includes Key Nos. 67-68	
34	22962-014	1/2" Hardened Washer	4	67	60238-001	1/2"-13 UNC Square Head Bolt	2
35	17700-034	1/2"-20 UNF Nylon Locknut	4	68	60240-000	1/2"-13 UNC Hex Jam Nut	2
36	67495-000	***Thrust Washer-Front Hanger, <i>only for vehicles prior to 01/2019, Replaces 66264-001</i>	4		34013-383	Clamp Group Fastener Kit, Axle Set , Includes Key Nos. 69-71	
	59829-001	Rear Hanger Assembly, Includes Key Nos. 37, 41-45	2	69	58917-001	3/4"-10 UNC x 4 1/4" Hex Bolt	8
37	59825-000	Rear hanger	2	70	22962-001	3/4" Hardened Washer	8
38		*3/4"-10 UNC Hex Bolt	2	71	17700-033	3/4"-10 UNC-2B Nylocknut	8
39		*3/4" Flat Washer	2	72	59826-002	Top Pad	2
40		*3/4"-10 UNC Locknut	2	73	57159-004	1/2" Dowel Pin - 2.63"	2
	60961-016	Rear Hanger Clamp Service Kit, One Side , Includes Key Nos. 41-46		74	68861-000	Caster Wedge	2
41	22962-033	3/4" Wide Washer	2	75	A-22930-4	ABS Sensor	2
42	59830-001	Rear Hanger Clamp	2	76	64550-000	ABS Sensor Clip	2
43	56935-001	1/4"-20 UNC x 1 1/4" Hex Bolt	4			Air Disc Brake Assembly, <i>see Page 6 for Contents</i>	2
44	22962-028	1/4" Hardened Washer	8				
45	49983-000	1/4"-20 UNC Locknut	4				
46	59346-001	Thrust Washer	4				
		STEERTEK NXT Axle Assembly , Includes Key Nos. 47-68	1				
	68977-003	13.5K					
	68977-006	14.6K					



AIRTEK® with STEERTEK™ NXT axle

Air Disc Brake Assembly

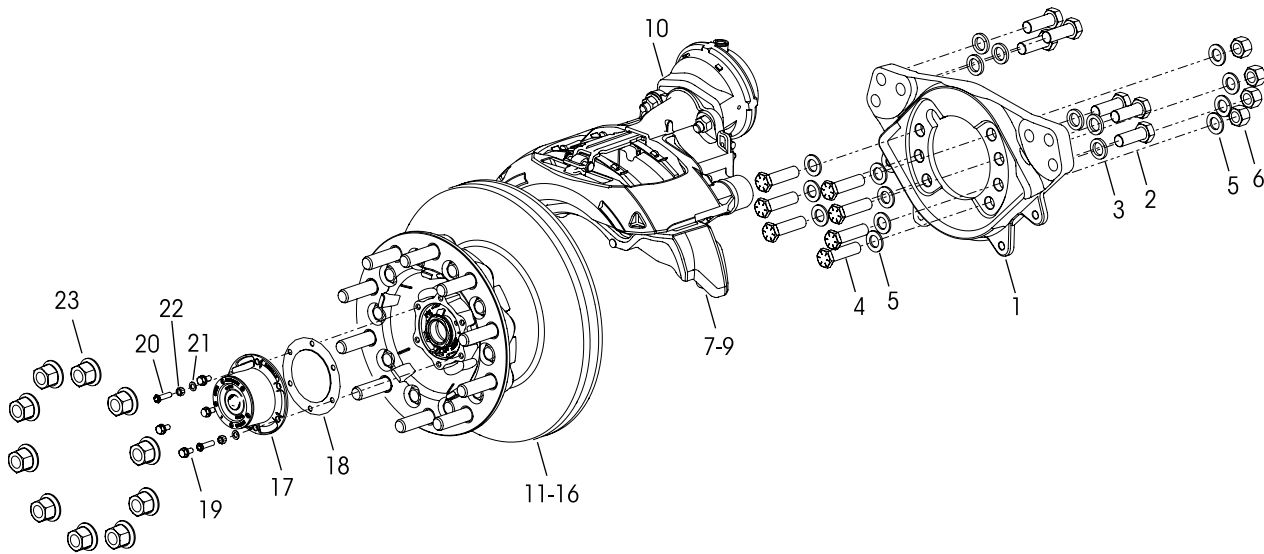

KEY NO.	PART NO.	DESCRIPTION	VEHICLE QTY.
1		****Bendix® Torque Plate Assembly Left Hand Part No. K114010 Right Hand Part No. K114011	1 1
2		M20 x 2.5 x 60 mm Caliper Bolt	12
3		M20 Flat Washer	12
4	80135-002	3/4"-10 UNC x 2 3/4" Hex Bolt	14
5	22962-001	3/4" Hardened Washer	22
6	49842-000	3/4"-10 UNC Locknut	8
7		****Bendix Brake Caliper/Carrier Assembly Left Hand Part No. K166122 Right Hand Part No. K166121	1 1
8		****Bendix Brake Pad Kit No. K129276, Axle Set (Includes hardware)	
9		****Bendix Shear Adapter for the Adjuster, Part No. 802455	
10		****Bendix Air Brake Chamber Part No. K028022	
		****Conmet® Hub and Rotor Assembly, Part No. 10083194, Includes Key Nos. 11-16	2
11		****Conmet Hub Bearing Rebuild Kit, Part No. 10081727	

KEY NO.	PART NO.	DESCRIPTION	VEHICLE QTY.
12		****Conmet Inner Bearing Cup and Cone Assembly, Part No. 10041905	
13		****Conmet Outer Bearing Cup and Cone Assembly, Part No. 10041906	
14		****Conmet Wheel Seal and Spacer Kit, Part No. 10081518	
15		****Conmet Seal Kit, Part No. 10045885	
16		****Conmet Rotor Service Kit, Part No. 10082074	
17		****Stemco Hubcap Assembly - 6", Kit No. 343-4346, Includes Key No. 18	2
18		****Stemco Hubcap Gasket Part No. 330-3024	2
19	64545-002	5/16"-18 UNC x 3/4" Hex Bolt with Retainer Washer (Hubcap Bolts)	8
20	10061-0004	5/16"-18 UNC x 2" Stud, Socket Head Set Screw (Hub Cover Bracket)	4
21	17497-015	5/16" Washer	4
22	6005CH2HB	5/16"-18 UNC Hex Nut	4
23		*M22 x 1.5 Two-piece Wheel Nut	20



Tie Rod Selection Guide

		Axle Model	Tie Rod Assembly Part Number	Tie Rod End Part Number	Tie Rod End Service Kit No.		
10K • 10.5K 12K • 12.6K • 13.5K	Straight Tie Rods 1 1/8" Threads	Vehicles built after November 2014					
		STEEERTEK NXT	76877-003	70995-001 (LH) 70995-002 (RH)	60961-734 (Axle Set) 60961-736 (LH) 60961-741 (RH)		
		* Vehicles built prior to November 2014					Tie Rod Assembly Replacement Part No.
		STEEERTEK	60239-003	* Tie rod end kits are no longer available for these assembly numbers, requires complete tie rod assembly replacement.		76877-003	
14.6K	Straight Tie Rods 1 1/4" Threads	Vehicles built after January 2019					
		STEEERTEK NXT	76879-003	76876-001 (LH) 76876-002 (RH)	60961-735 (Axle Set) 60961-742 (LH) 60961-743 (RH)		
		* Vehicles built prior to January 2019					Tie Rod Assembly Replacement Part No.
		STEEERTEK	64006-003	* Tie rod end kits are no longer available for these assembly numbers, requires complete tie rod assembly replacement.		76879-003	
NOTE: * Hendrickson supplies different tie rod assemblies and each type may take a different replacement tie rod end kit to service. Prior to ordering, find the part number on the tie rod tube, refer to Hendrickson Publication No. SEU-0223 or contact Hendrickson Truck Parts for corresponding Kit Numbers.							

NOTES: * Not supplied by Hendrickson, used for reference only. Contact the vehicle manufacturer for more information.

** Item included in assembly/kit only, part not sold separately.

*** New production and aftermarket replacement leaf spring assemblies as of 01/19 (Part Nos. 82598-000 and 82599-000) **DO NOT** require thrust washers. Thrust washers (Part No. 67495-000) are only required for previous production vehicles equipped with leaf spring assemblies (Part Nos. 59930-031 or 59930-032). If one leaf spring requires replacement both leaf springs need to be replaced.

**** Not supplied by Hendrickson for aftermarket service purposes. Description and part number listed for reference only. For more information and assistance with service, maintenance and rebuild instructions on these components see below component manufacturers:

- Bendix 1-800-AIR-BRAKE, customer service option 1, Tech Team, option 2. Online part number support go to: www.bendix.com/en/service/support/partnumbersearch/partnumbersearch_1.jsp
Online technical support training go to: www.brake-school.com
- Conmet Technical and Part Support 800.547.9473 or go to aftermarket.conmetwheelends.com/hub-selection
- Federal Mogul Technical and Part Support 800.325.8886 or go to www.fme-cat.com
- Meritor Technical and Part Support 888.725.9355, or for parts www.meritorpartsexpress.com and for technical support www.meritorbullpen.com
- Stemco Technical and Part Support 800.527.8492 or go to www.stemco.com
- Timken at Technical and Part Support 866.984.6536 or go to www.timken.com/resources or Timken YouTube series, Timken Tricks of the Trade (Installing a Timken® Set-Right® Bearing)
- WABCO Technical and Part Support 855.228.3203 or go to www.wabco-auto.com/emea/Services-and-Support/Services-and-Support
- Webb technical and part support 800.633.3256 or online at www.webbwheel.com

Hendrickson **AIRTEK Ride Height Gauges** for Spartan, order online www.hendrickson-intl.com/Liform

- Lit. No. 45745-289 – 10.5K • 12K Capacity
- Lit. No. 45745-288 – 12.4K • 12.6K • 13.5K • 14.6K Capacity



AIRTEK® with STEERTEK™ axle built prior to May 2019

Equipped with Drum Brakes – 10.5K • 12K • 12.6K • 14.6K Capacity

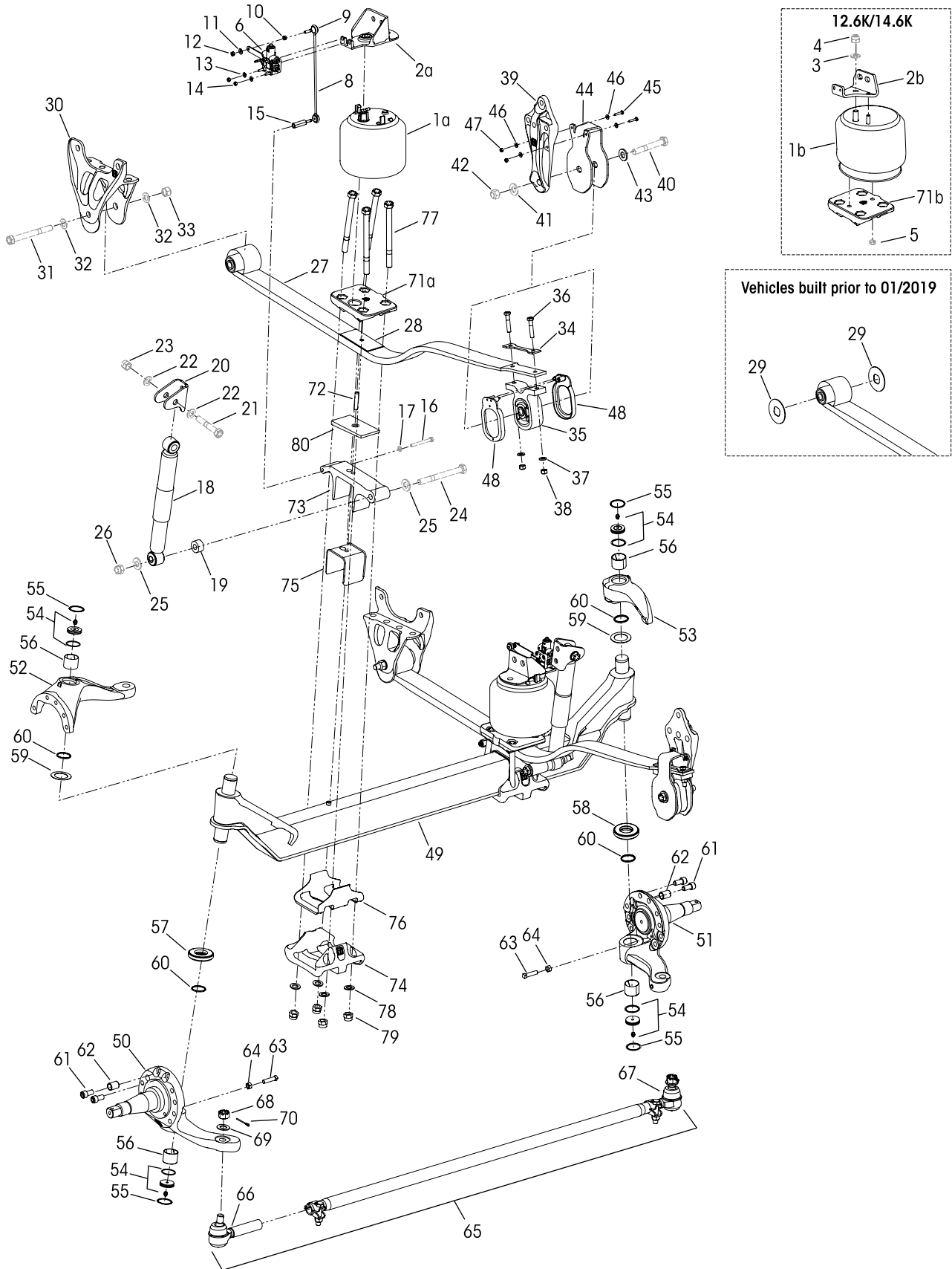



AIRTEK® with STEERTEK™ Axle for Spartan Motorhome Chassis with Drum Brakes

KEY NO.	PART NO.	DESCRIPTION	VEHICLE QTY.	KEY NO.	PART NO.	DESCRIPTION	VEHICLE QTY.
1		Air Spring	2			STEERTEK Axle Assembly,	1
a	66349-002L	10.5K • 12K				Includes Key Nos. 49-76, and Drum Brake Assembly, <i>see Page 10 for contents</i>	
b	65790-002L	12.6K • 14.6K		64502-044	10.5K • 12K • 12.6K with 15 x 4 Wheel Ends, <i>Replaces 64502-041</i>		
2		Upper Air Spring Bracket	2	64502-045	14.6K with 16.5 x 5 Wheel Ends, <i>Replaces 64502-042</i>		
a	60850-002	10.5K • 12K		49	Axle & Kingpin Assembly		1
b	66140-000	12.6K • 14.6K		64905-001	10.5K • 12K • 12.6K		
3		*3/4" Flat Washer	2	64905-005	14.6K		
4		*3/4"-16 UNF Locknut	2		Lower Steering Knuckle Assembly, Includes Key Nos. 56, 60, 62		
5		* 1/2"-13 UNC Locknut	2	50	Left Hand		1
	66277-001	Height Control Valve & Linkage Assembly Left Hand, Includes Key Nos. 6, 8-14	1	51	Right Hand		1
	66277-002	Right Hand, Includes Key Nos. 7-14	1		Upper Steering Knuckle Assembly, Includes Key Nos. 56, 60		
		Height Control Valve		52	Left Hand		1
6	66414-001	Left Hand	1	53	Right Hand		1
7	66414-002	Right Hand	1		Kingpin Bushing and Bearing Service Kits		
8	59428-001	HCV Linkage - 335 mm	2	60961-040	Axle Set, Includes Kit Nos. 60961-009 & -039		
9	59169-000	5/16"-18 UNC Stud	2	60961-009	Left Hand with Composite Thrust Bearing,		
10	17491-011	5/16"-18 UNC Nut	2		Includes Key Nos. 54-57, 59-61 & Loctite		
11	22962-029	5/16" Hardened Washer	2	60961-039	Right Hand with Roller Thrust Bearing,		
12	59016-000	5/16"-18 UNC Locknut	2		Includes Key Nos. 54-56, 58-61 & Loctite		
13	22962-028	1/4" Hardened Washer	4	54	59156-000 Grease Cap Assembly		4
14	49983-000	1/4"-20 UNC Locknut	4	55	58937-000 Retaining Ring		4
15	59429-001	Lower Link Mount	2	56	58909-000 Kingpin Bushing		4
16		*3/8"-16 UNC x 3 1/2" Hex Bolt	2		Thrust Bearing Service Kits		
17		*3/8" Flat Washer	2	60961-043	Axle Set, Includes Kit Nos. 60961-041 & -042		
18		Shock Absorber, <i>Replaces 66153-001</i>	2	60961-041	Left Hand Composite Thrust Bearing,		
	66153-006	10.5K • 12K • 12.6K			Includes Key Nos. 57, 59-61 & Loctite		
	66153-007	14.6K		60961-042	Right Hand Roller Thrust Bearing,		
19	59946-001	Shock Spacer	2		Includes Key Nos. 58-61 & Loctite		
20	66589-002	Shock Bracket	2	57	59828-000 Left Hand Composite Thrust Bearing		1
21		*3/4" Upper Shock x 3 3/4" Bolt	2	58	64256-000 Right Hand Roller Thrust Bearing		1
22		*3/4" Upper Shock Washer	4	59	Kingpin Shim		As Req.
23		*3/4" Upper Shock Locknut	2	60259-001X	0.005" Thickness (Pack of 4)		
24		*3/4" Lower Shock x 7 1/2" Bolt	2	60259-002	0.047" Thickness		
25		*3/4" Lower Shock Washer - 2" Wide	4	60	58910-001 Kingpin Seal, <i>Replaces 58910-000</i>		4
26		*3/4" Lower Shock Locknut	2	61	60236-001 5/8"-11 UNC Socket Head Cap Screw		4
		***Leaf Spring Assembly, Includes Key Nos. 27-29, 34-38, 48			60937-000 Loctite (Red) Compound Tube (Not Shown)		1
	82598-000	Left Hand, <i>replaces 59930-031</i>	1	62	64246-000 ABS Sensor Sleeve		2
	82599-000	Right Hand, <i>replaces 59930-032</i>	1		60961-069 Stop Bolt Service Kit, One End,		
27		**Leaf Spring with Spring Eye Bushing	2		Includes Key Nos. 63-64		
28		**Galvanized Liner	2	63	60238-001 1/2"-13 UNC x 2" Square Head Bolt		2
29	67495-000	***Thrust Washer-Front Hanger, <i>only for vehicles prior to 01/19, Replaces 66264-001</i>	4	64	60240-000 1/2"-13 UNC Hex Jam Nut		2
30	64488-000	Front Hanger	2	65	Tie Rod Assembly, Includes Key Nos. 66-68		1
31		*M20 x 170 mm Bolt	2		<i>See Selection Guide on Page 7</i>		
32		*M20 Washer	4		60961-XXX Tie Rod End Service Kits, See Selection Guide on Page 7		
33		*M20 Locknut	2		Axle Set, Includes Left Hand & Right Hand Kits		
	60961-002	Rear Spring Mount Service Kit, One Side,			Left Hand, Includes Key Nos. 66, 68-70		
		Includes Key Nos. 34-38			Right Hand, Includes Key Nos. 67-70		
34	58920-000	Spring End Plate	2		Tie Rod Ends, Includes Key No. 68, <i>See Selection Guide on Page 7</i>		
35	58918-000	Rear Spring Mount	2	66	Left Hand,		1
36	30970-011	1/2"-20 UNF x 2 1/4" Hex Bolt	4	67	Right Hand		1
37	22962-014	1/2" Hardened Washer	4	68	**7/8" Castle Nut		2
38	17700-034	1/2"-20 UNF Nylon Locknut	4	69	22962-007 7/8" Hardened Washer		2
	59829-001	Rear Hanger Assembly, Includes Key Nos. 39, 43-47	2	70	17800-004 Cotter Pin		2
39	59825-000	Rear hanger	2	71	Top Pad		2
40		*3/4"-10 UNC x 4 3/4" Hex Bolt	2	a	66144-000 10.5K • 12K		
41		*3/4" Flat Washer	2	b	66191-000 12.6K • 14.6K		
42		*3/4"-10 UNC Locknut	2	72	57159-004 1/2" Dowel Pin - 2.63"		2
	60961-016	Rear Hanger Clamp Service Kit, One Side,		73	59952-028 Top Axle Wrap, <i>Replaces 59952-001</i>		2
		Includes Key Nos. 43-48		74	64723-005 Bottom Axle Wrap		2
43	22962-033	3/4" Wide Washer	2				
44	59830-001	Rear Hanger Clamp	2				
45	56935-001	1/4"-20 UNC x 1 1/4" Hex Bolt	4				
46	22962-028	1/4" Hardened Washer	8				
47	49983-000	1/4"-20 UNC Locknut	4				
48	59346-001	Thrust Washer	4				



KEY NO.	PART NO.	DESCRIPTION	VEHICLE QTY.	KEY NO.	PART NO.	DESCRIPTION	VEHICLE QTY.
		Top/Bottom Axle Wrap Liner Service Kit, One Side, Includes Key Nos. 75-79		77		3/4"-10 UNC x 9" Hex Bolt	8
	60961-164	• For all vehicles built after 02/07			68715-353	• For all vehicles built after 02/07, Replaces 58917-013	
	60961-013	• For vehicles built prior to 02/07			58917-016	• For vehicles built prior to 02/07	
	60961-164	10.5K • 12K • 12.6K			68715-353	10.5K • 12K • 12.6K	
		14.6K				14.6K, Replaces 58917-013	
75	59449-000	Top Axle Wrap Liner	2	78	22962-001	3/4" Hardened Washer	8
76	59845-000	Bottom Axle Wrap Liner	2	79	17700-033	3/4"-10 UNC-2B Nylocknut	8
		Clamp Group Fastener Kit, Axle Set, Includes Key Nos. 77-79		80	68861-000	Caster Wedge	2
	60961-113	• For all vehicles built after 02/07				Drum Brake Assembly, see Parts List below for Contents	2
	60961-150	• For vehicles built prior to 02/07					
	60961-150	10.5K • 12K • 12.6K					
	60961-113	14.6K					

AIRTEK® with STEERTEK™ axle

Drum Brake Assembly

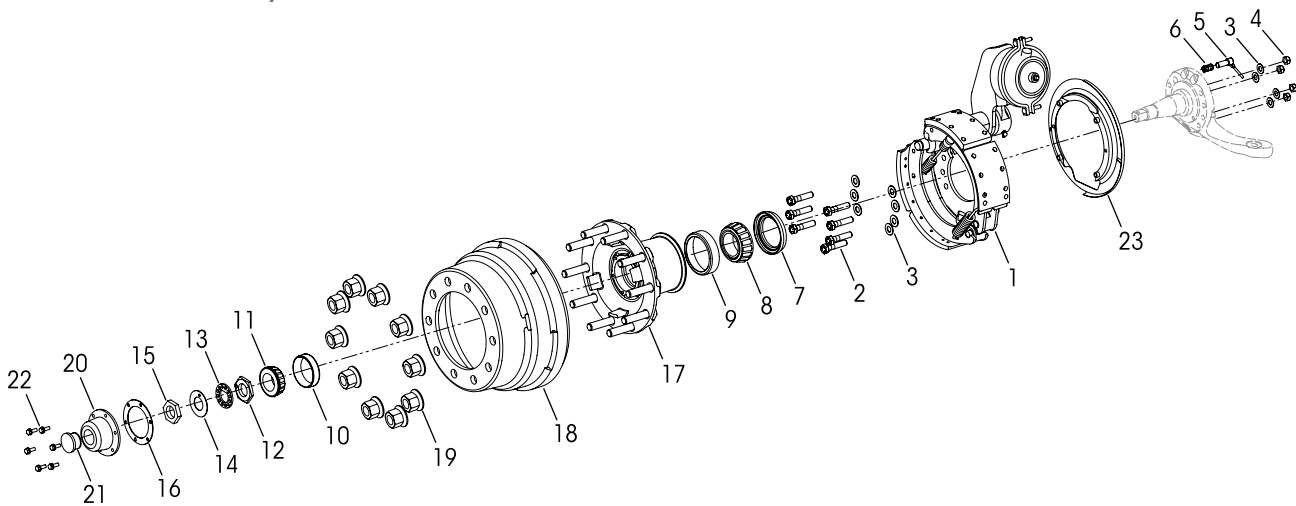

KEY NO.	PART NO.	DESCRIPTION	VEHICLE QTY.	KEY NO.	PART NO.	DESCRIPTION	VEHICLE QTY.
1		****Meritor Drum Brake Assembly, AIRTEK 10.5K, 12K, 12.6K, 15" x 4" Left Hand Part No. QP4-1540-3085 Right Hand Part No. QP4-1540-3086 AIRTEK 14.6K, 16.5" x 5" Left Hand Part No. QP4-1655-893 Right Hand Part No. QP4-1655-894	1 1 1 1	12		****Meritor 1 1/2"-12 UNF Inner Wheel Bearing Adj. Nut Part No. 1227-U-541	2
2	32043-002	5/8"-11 UNC x 2 3/4" Hex Bolt	14	13		****Meritor 3/8" Wheel End Lock Ring Part No. 1229-G-475	2
3	22962-036	5/8" Hardened Washer	22	14		****Meritor 0.05" Wheel End Lock Washer Part No. 1229-F-474	2
4	47764-000	5/8"- UNC Locknut	8	15		****Meritor Wheel End Outer Nut No. 1227-B-106	2
5	64547-000	ABS Sensor	2	16		****Stemco Hubcap Gasket Part No. 330-3024	2
6	64550-000	ABS Sensor Clip	2	17		****Webb Hub Part No. 25201-1T	2
7		****Federal Mogul Wheel Seal Kit No. M380001TX0	2	18		****Webb Drum AIRTEK 10.5K, 12K, 12.6K, Part No. 65545B AIRTEK 14.6K, Part No. 65163B	2
		****Timken Inner Bearing One side, Set No. 413, Includes Key Nos. 88-89		19		*M22 x 1.5 Two-piece Wheel Nut	20
8		Inner Bearing Cone	2	20		****Stemco Hubcap Assembly - 6", Kit No. 343-4346, Includes Key No. 70	2
9		Inner Bearing Cup	2	21		**Rubber Plug	2
		****Timken Outer Bearing One Side, Set No. 406, Includes Key Nos. 90-91		22	64545-002	5/16"-18 UNC x 3/4" Hex Bolt with Retainer Washer 12 (Hubcap Bolts), Replaces 64545-001	12
10		Outer Bearing Cup	2	23		**Meritor Dust Shield AIRTEK 10.5K, 12K, 12.6K, Part No. 3264-R-1292 AIRTEK 14.6K, Part No. 3264-N-118	2
11		Outer Bearing Cone	2				



Special Tool

KINGPIN BUSHING TOOL – ADJUSTABLE STRAIGHT FLUTE REAMER

The dimension of cutting diameter must facilitate a range of 1.802" – 1.812"





SOFTEK® with STEERTEK™ axle built prior to May 2019

Equipped with Air Disc Brakes – 10K Capacity

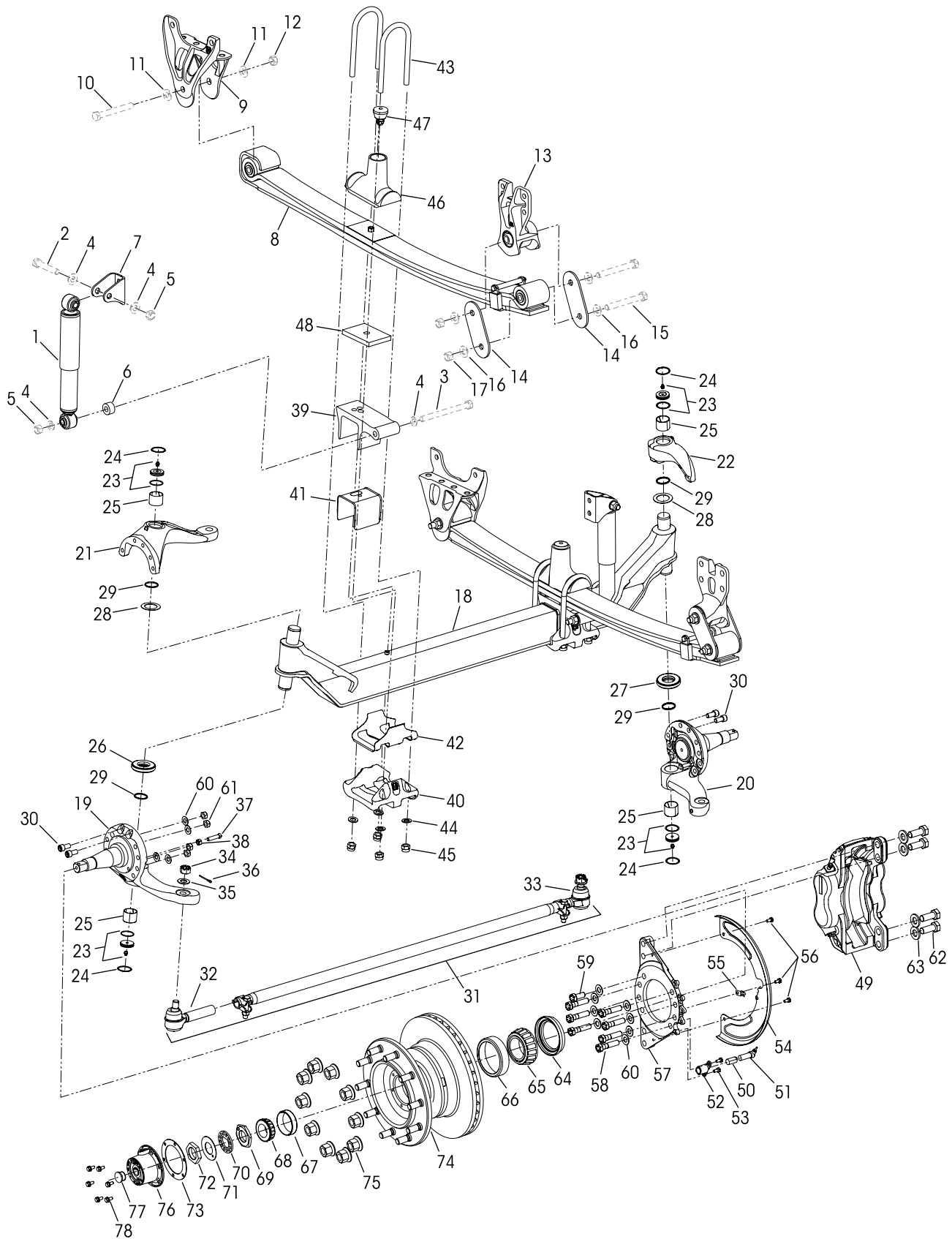



SOFTEK® with STEERTEK™ Axle for Spartan Bus equipped with Air Disc Brakes

VEHICLE				VEHICLE			
KEY NO.	PART NO.	DESCRIPTION	QTY.	KEY NO.	PART NO.	DESCRIPTION	QTY.
1	58913-009L	Shock Absorber	2	37	60238-001	½"-13 UNC x 2" Square Head Bolt	2
2		*¾"-10 UNC Upper Shock Bolt	2	38	60240-000	½"-13 UNC Hex Jam Nut	2
3		*¾"-10 UNC Lower Shock Bolt	2	39	59952-003	Top Axle Wrap	2
4		*¾" Hardened Washer	8	40	64722-003	Bottom Axle Wrap	2
5		*¾"-10 UNC Hex Locknut	4	41	60508-000	Top Axle Wrap Liner, <i>Replaces 59449-000</i>	2
6	59946-001	Shock Spacer	2	42	59845-000	Bottom Axle Wrap Liner	2
7	59423-002	Shock Bracket	2		60961-140	Clamp Group Service Kit, One side, Includes Key Nos. 43-45	
	60961-162	Leaf Spring Assembly Service Kit, Includes Key Nos. 8, 13-14		43	64804-110	¾"-16 UNF x 11" U-bolt	4
8	53624-000	Leaf Spring Assembly, <i>Replaces 66624-001</i>	2	44	22962-001	¾" Flat Washer	8
9	64488-002	Front Hanger	2	45	17700-035	¾"-16 UNF 2B Nylon Locknut	8
10		*M20 Hex Bolt	2		64506-000	Top Pad/Axle Stop Assembly Includes Key Nos. 46-47	
11		*M20 Hardened Washer	4	46	64519-000	Top Pad	2
12		*M20 Locknut	2	47	64080-000	Rubber Axle Stop	2
13	66510-001	Rear Shackle Bracket	2	48	70105-010	Front Axle Spacer, <i>Replaces 64536-010</i>	2
14	64314-000	Rear Shackle Plate	4		18831-021	Dowel Pin 2" (Not Shown)	2
15		*M20 x 150 mm Hex Bolt	4	49		****Meritor Brake Caliper Assembly Left Hand Part No. 60450482007 Right Hand Part No. 60450483007	2
16		*M20 Hardened Washer	8	50		****Wabco ABS Sensor Clip Part No. 300088	2
17		*M20 Locknut	4	51		****Wabco ABS Sensor Part No. 441 032 814 0	2
18	64905-001	Axle & Kingpin Assembly	1	52		****Meritor ABS Bracket Part No. 69180466	2
		Lower Steering Knuckle Assembly, Includes Key Nos. 25, 29		53	18160-012	⅝"-18 UNC x ½" Bolt (ABS Bracket)	4
19	58900-027	Left Hand	1	54		****Meritor Dust Shield Part No. 3264W1453	2
20	58900-028	Right Hand	1	55		****Meritor Dust Shield Clip Part No. 2257V1270	2
		Upper Steering Knuckle Assembly, Includes Key Nos. 25, 29		56	64201-001	M8 x 1¼"-6G Cap Screw (Dust Shield)	6
21	60903-004	Left Hand	1	57		****Meritor Torque Plate Left Hand Part No. 69120952 Right Hand Part No. 69120951	2
22	60904-002	Right Hand	1	58	32043-002	⅝"-11 UNC x 2¾" Hex Bolt (Torque Plate)	14
		Kingpin Bushing and Bearing Service Kits		59	32043-021	⅝"-11 UNC x 1½" Hex Bolt (Torque Plate)	2
	60961-040	Axle Set, Includes Kit Nos. 60961-009 & -039		60	22962-036	⅝" Hardened Washer (Torque Plate)	24
	60961-009	Left Hand with Composite Thrust Bearing, Includes Key Nos. 23-26, 28-30 & Loctite		61	47764-000	⅝"-11 UNC Locknut (Torque Plate)	8
	60961-039	Right Hand with Roller Thrust Bearing, Includes Key Nos. 23-25, 27-30 & Loctite		62	58258-017	M20 x 2.5-6G Hex Bolt (Caliper)	8
23	59156-000	Grease Cap Assembly	4	63	58246-018	M20 Hardened Washer (Caliper) <i>Replaces 58246-009</i>	8
24	58937-000	Retaining Ring	4	64		****Federal Mogul Wheel Seal Kit No. M380001TX0	2
25	58909-000	Kingpin Bushing	4			****Timken Inner Bearing One side, Set No. 413, Includes Key Nos. 65-66	
		Thrust Bearing Service Kits		65		Inner Bearing Cone	2
	60961-043	Axle Set, Includes Kit Nos. 60961-041 & -042		66		Inner Bearing Cup	2
	60961-041	Left Hand Composite Thrust Bearing, Includes Key Nos. 26, 28-30 & Loctite				****Timken Outer Bearing One Side, Set No. 406, Includes Key Nos. 67-68	
	60961-042	Right Hand Roller Thrust Bearing, Includes Key Nos. 27-30 & Loctite		67		Outer Bearing Cup	2
26	59828-000	Left Hand Composite Thrust Bearing	1	68		Outer Bearing Cone	2
27	64256-000	Right Hand Roller Thrust Bearing	1	69		****Meritor 1½"-12 UNF Inner Wheel Bearing Adj. Nut Part No. 1227-U-541	2
28		Kingpin Shim	As Req.	70		****Meritor ⅜" Wheel End Lock Ring Part No. 1229-G-475	2
	60259-001X	0.005" Thickness (Pack of 4)		71		****Meritor 0.05" Wheel End Lock Washer Part No. 1229-F-474	2
	60259-002	0.047" Thickness		72		****Meritor Wheel End Outer Nut No. 1227-B-106	2
29	58910-001	Kingpin Seal	4	73		****Stemco Hubcap Gasket Part No. 330-3024	2
30	60236-001	⅝"-11 UNC Socket Head Cap Screw	4	74		****Meritor Hub & Rotor Assembly, Steel Hub 15.38 x 1.54 Rotor Part No. 17160671003	2
	60937-000	Loctite (Red) Compound Tube (Not Shown)	1	75		*M22 x 1.5 Two-piece Wheel Nut	20
31		Tie Rod Assembly, Includes Key Nos. 32-34 <i>See Selection Guide on Page 7</i>	1	76		****Stemco Hubcap Assembly - 6" Kit No. 343-4346, Includes Key No. 77	2
	60961-XXX	Tie Rod End Service Kits, See Selection Guide <i>on Page 7</i>		77		**Rubber Plug	2
		Axle Set, Includes Left Hand & Right Hand Kits		78	64545-002	⅝"-18 UNC x ¾" Hex Bolt with Retainer Washer (Hubcap Bolts)	12
		Left Hand, Includes Key Nos. 32, 34-36					
		Right Hand, Includes Key Nos. 33-36					
		Tie Rod Ends, Includes Key No. 34, <i>See Selection</i> <i>Guide on Page 7</i>					
32		Left Hand	1				
33		Right Hand	1				
34		**⅞" Castle Nut	2				
35	22962-007	⅞" Flat Washer	2				
36	17800-004	Tie Rod Nut Cotter Pin	2				
	60961-069	Stop Bolt Service Kit, One Side, Includes Key Nos. 37-38					



SOFTEK® with STEERTEK™ Axle for Spartan Bus equipped with Drum Brakes

VEHICLE				VEHICLE			
KEY NO.	PART NO.	DESCRIPTION	QTY.	KEY NO.	PART NO.	DESCRIPTION	QTY.
1	58913-009L	Shock Absorber	2			Tie Rod Ends, Includes Key No. 35, <i>See Selection Guide on Page 7</i>	
2		*¾"-10 UNC Upper Shock Bolt	2	33		Left Hand	1
3		*¾"-10 UNC Lower Shock Bolt	2	34		Right Hand	1
4		*¾" Hardened Washer	8	35		**⅞" Castle Nut	2
5		*¾"-10 UNC Hex Locknut	4	36	22962-007	⅞" Flat Washer	2
6	59946-001	Shock Spacer	2	37	17800-004	Tie Rod Nut Cotter Pin	2
7	59423-002	Shock Bracket	2		60961-069	Stop Bolt Service Kit, One Side, Includes Key Nos. 38-39	
	60961-162	Leaf Spring Assembly Service Kit, Includes Key Nos. 8, 13-14		38	60238-001	½"-13 UNC x 2" Square Head Bolt	2
8	53624-000	Leaf Spring Assembly, <i>Replaces 66624-001</i>	2	39	60240-000	½"-13 UNC Hex Jam Nut	2
9	64488-002	Front Hanger	2	40	59952-003	Top Axle Wrap	2
10		*M20 Hex Bolt	2	41	64722-003	Bottom Axle Wrap	2
11		*M20 Hardened Washer	4	42	60508-000	Top Axle Wrap Liner, <i>Replaces 59449-000</i>	2
12		*M20 Locknut	2	43	59845-000	Bottom Axle Wrap Liner	2
13	66510-001	Rear Shackles Bracket	2		60961-140	Clamp Group Service Kit, One side, Includes Key Nos. 44-46	
14	64314-000	Rear Shackles Plate	4	44	64804-110	¾"-16 UNF x 1 1/8" U-bolt	4
15		*M20 Hex Bolt	4	45	22962-001	¾" Flat Washer	8
16		*M20 Hardened Washer	8	46	17700-035	¾"-16 UNF 2B Nylon Locknut	8
17		*M20 Locknut	4		64506-000	Top Pad/Axle Stop Assembly, Includes Key Nos. 47-48	
18	64905-001	Axle & Kingpin Assembly	1	47	64519-000	Top Pad	2
		Lower Steering Knuckle Assembly, Includes Key Nos. 25, 29, 31		48	64080-000	Rubber Axle Stop	2
19	58900-027	Left Hand	1	49	70105-010	Front Axle Spacer, <i>Replaces 64536-010</i>	2
20	58900-028	Right Hand	1		18831-021	Dowel Pin 2" (Not Shown)	2
		Upper Steering Knuckle Assembly, Includes Key Nos. 25, 29		50		****Meritor Dust Shield Part No. 3264-R-1292	2
21	60903-004	Left Hand	1	51		****Meritor Drum Brake Assembly, 15" x 4"	
22	60904-002	Right Hand	1			Left Hand Part No. QP4-1540-3085	1
		Kingpin Bushing and Bearing Service Kits				Right Hand Part No. QP4-1540-3086	1
	60961-040	Axle Set, Includes Kit Nos. 60961-009 & -039		52	32043-002	⅝"-11 UNC x 2 3/4" Hex Bolt	14
	60961-009	Left Hand with Composite Thrust Bearing, Includes Key Nos. 23-26, 28-30 & Loctite		53	22962-036	⅝" Hardened Washer	22
	60961-039	Right Hand with Roller Thrust Bearing, Includes Key Nos. 23-25, 27-30 & Loctite		54	47764-000	⅝"- UNC Locknut	8
23	59156-000	Grease Cap Assembly	4	55	64547-000	ABS Sensor	2
24	58937-000	Retaining Ring	4	56	64550-000	ABS Sensor Clip	2
25	58909-000	Kingpin Bushing	4	57		****Federal Mogul Wheel Seal Kit No. M380001TX0	2
		Thrust Bearing Service Kits				****Timken Inner Bearing One side, Set No. 413, Includes Key Nos. 58-59	
	60961-043	Axle Set, Includes Kit Nos. 60961-041 & -042		58		Inner Bearing Cone	2
	60961-041	Left Hand Composite Thrust Bearing, Includes Key Nos. 26, 28-30 & Loctite		59		Inner Bearing Cup	2
	60961-042	Right Hand Roller Thrust Bearing, Includes Key Nos. 27-30 & Loctite				****Timken Outer Bearing One Side, Set No. 406, Includes Key Nos. 60-61	
26	59828-000	Left Hand Composite Thrust Bearing	1	60		Outer Bearing Cup	2
27	64256-000	Right Hand Roller Thrust Bearing	1	61		Outer Bearing Cone	2
28		Kingpin Shim	As Req.	62		****Meritor 1 1/2"-12 UNF Inner Wheel Bearing Adj. Nut Part No. 1227-U-541	2
	60259-001X	0.005" Thickness (Pack of 4)		63		****Meritor 3/16" Wheel End Lock Ring Part No. 1229-G-475	2
	60259-002	0.047" Thickness		64		****Meritor 0.05" Wheel End Lock Washer Part No. 1229-F-474	2
29	58910-001	Kingpin Seal	4	65		****Meritor Wheel End Outer Nut No. 1227-B-106	2
30	60236-001	⅝"-11 UNC Socket Head Cap Screw	4	66		****Stemco Hubcap Gasket Part No. 330-3024	2
	60937-000	Loctite (Red) Compound Tube (Not Shown)	1	67		****Webb Hub Part No. 25201-1T	2
31	64246-000	ABS Sensor Sleeve	2	68		****Webb Drum Part No. 65545B	2
32		Tie Rod Assembly, Includes Key Nos. 33-35 <i>See Selection Guide on Page 7</i>	1	69		*M22 x 1.5 Two-piece Wheel Nut	20
	60961-XXX	Tie Rod End Service Kits, See Selection Guide on Page 7		70		****Stemco Hubcap Assembly - 6", Kit No. 343-4346, Includes Key No. 71	2
		Axle Set, Includes Left Hand & Right Hand Kits		71		**Rubber Plug	2
		Left Hand, Includes Key Nos. 33, 35-37		72	64545-002	⅝"-18 UNC x ¾" Hex Bolt with Retainer Washer (Hubcap Bolts)	12
		Right Hand, Includes Key Nos. 34-37					

This is a general parts list to provide directional information. Components may vary by model. Questions in regards to parts, contact Hendrickson Truck Parts at 1.866.755.5968 (Toll-free U.S. and Canada), 630.910.2800 (Outside U.S. and Canada) or e-mail: truckparts@hendrickson-intl.com.

Actual product performance may vary depending upon vehicle configuration, operation, service and other factors.

All applications must comply with applicable Hendrickson specifications and must be approved by the respective vehicle manufacturer with the vehicle in its original, as-built configuration. Contact Hendrickson for additional details regarding specifications, applications, capacities, and operation, service and maintenance instructions.

Call Hendrickson at 1.866.755.5968 (toll-free) or 1.630.910.2800 for additional information.



www.hendrickson-intl.com

SP-184 Rev H 03-20

© 2017 – 2020 Hendrickson USA, L.L.C. All Rights Reserved. All trademarks shown are owned by Hendrickson USA, L.L.C., or one of the affiliates, in one or more countries.

Information contained in this literature was accurate at the time of publication. Product changes may have been made after the copyright date that are not reflected.

TRUCK COMMERCIAL VEHICLE SYSTEMS

800 South Frontage Road

Woodridge, IL 60517-4904 USA

1.866.755.5968 (Toll-free U.S. and Canada)

1.630.910.2800 (Outside U.S. and Canada)

Fax 1.630.910.2899

Printed in United States of America