

H TECHNICAL PROCEDURE PIVOT BUSHINGS

SUBJECT: Bushing Tube Spacer
Inspection / Replacement Procedure

LIT NO: L750

DATE: October 2020

REVISION: D

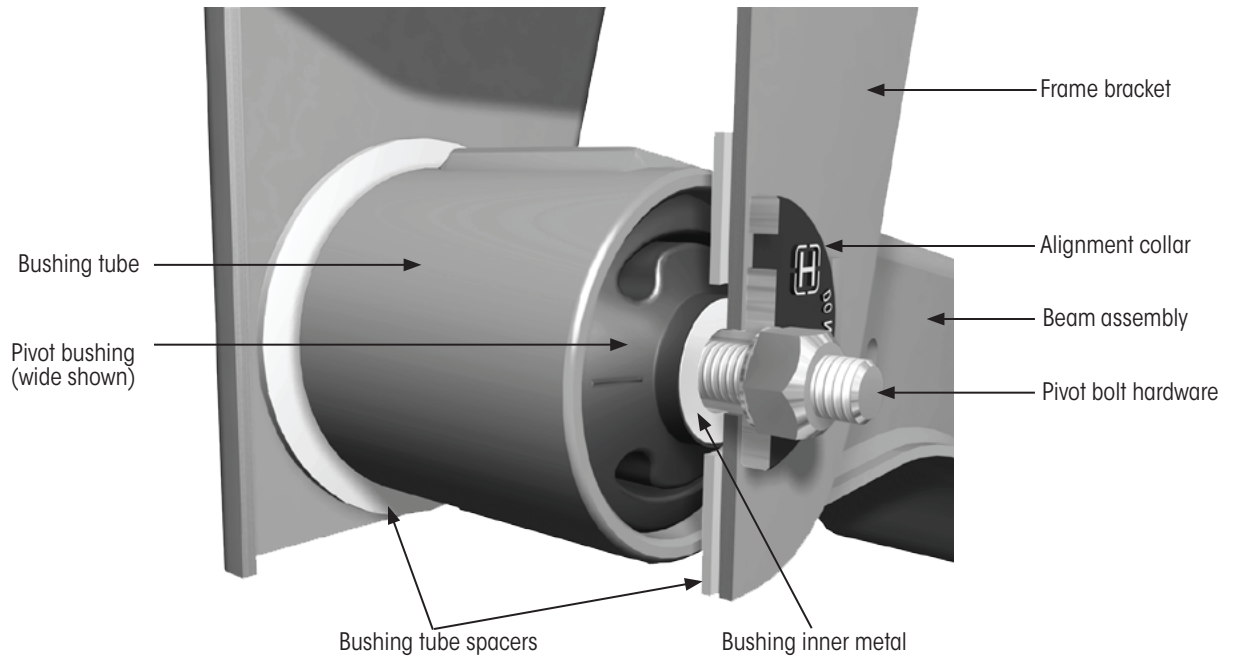

TABLE OF CONTENTS

Inspecting Bushing Tube Spacers	2
Evaluating Bushing Position Within The Bushing Tube	4
If Bushing Tube Spacer is Worn Through	4
Evaluating Frame Bracket Wear	5
Evaluating Bushing Tube Wear.....	5
Repair Recommendations.....	6
Bushing Tube Edge Dressing	7
Installing The New Bushing	7
Replacement Bushing Tube Spacer, Wide Bushing	8

This document, along with the following Hendrickson publications, comprise the complete set of bushing, bushing tube and bushing tube spacer inspection, evaluation and replacement information:

- L1071** *Pivot Bushing Inspection/Replacement Information*
- L1073** *Fixed Suspension Installation Information and Requirements*
- L1074** *Slider Suspension Installation Information and Requirements*
- L578** *Preventive Maintenance Guide*

These Hendrickson publications, and any others that may be referenced on the following pages, are available as free downloads from www.Hendrickson-intl.com/TrailerLit. If more information is required, contact **Hendrickson Trailer Technical Services**: in the United States and Canada at 866-RIDEAIR (743-3247) or email HTTS@Hendrickson-intl.com.

The bushing tube (shown on front cover) evaluation information in this document applies to both wide and narrow bushing types (Table 1).

BUSHING TYPE	BUSHING TUBE WIDTH	APPLICABLE SUSPENSION TYPES
Wide	6"	INTRAAX®, VANTRAAX® and HT™ Series
Narrow	3 1/8"	INTRAAX, VANTRAAX and ULTRA-K®

Table 1: *Bushing types*

INSPECTING BUSHING TUBE SPACERS

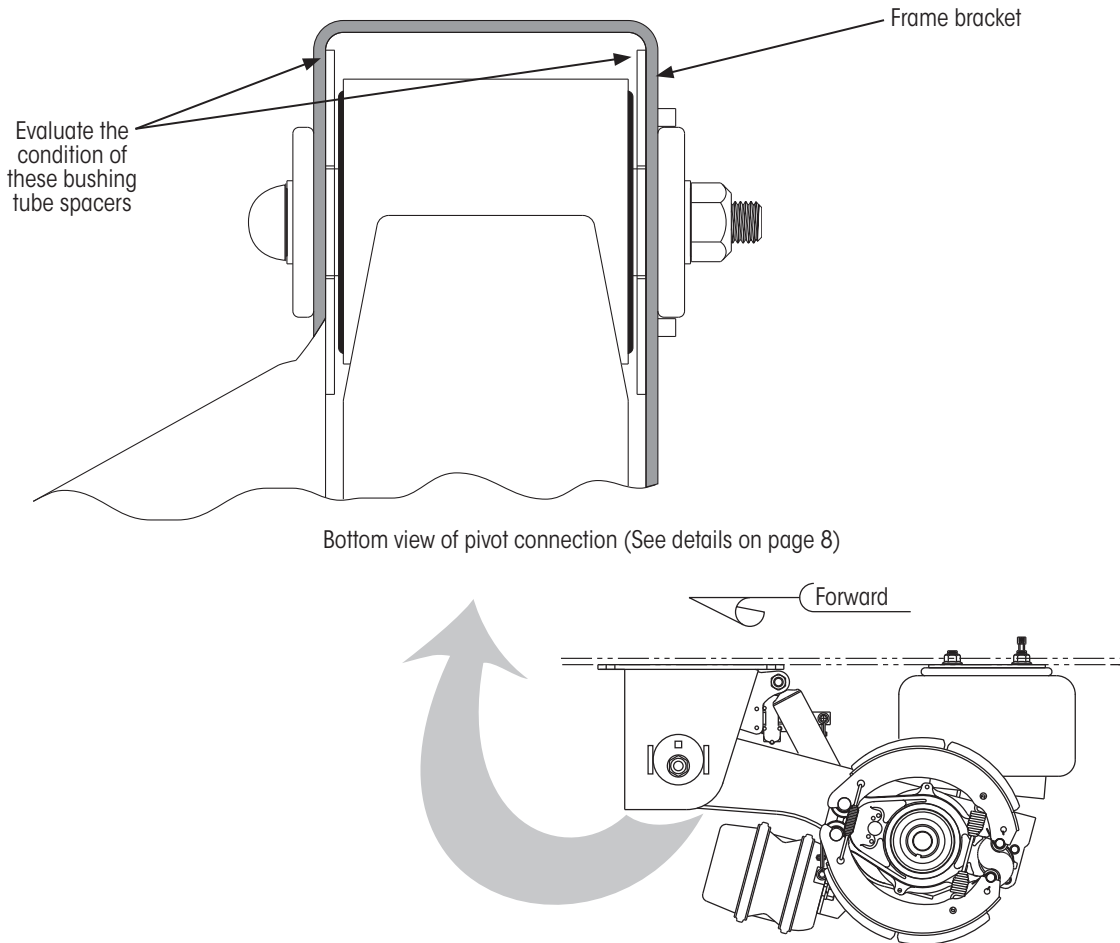

Bottom view of pivot connection (See details on page 8)

Figure 1: *Bushing tube spacer location*



BUSHING TUBE SPACER INSPECTION / REPLACEMENT PROCEDURE

Periodic inspections are an important part of an air suspension maintenance routine. Of particular importance are the bushing tube spacers, which are located inside the frame brackets on each side of the pivot bushing (front cover and Figure 1). For inspection intervals, refer to Hendrickson literature number *L578 Preventive Maintenance Guide*. An evaluation should include all bushing tube spacers on the trailer.

NORMAL

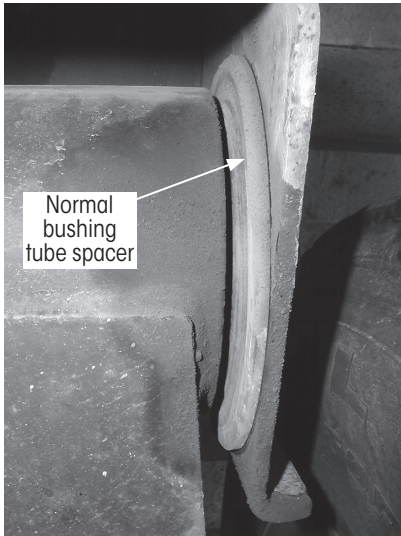

"CUPPED" — ALSO NORMAL

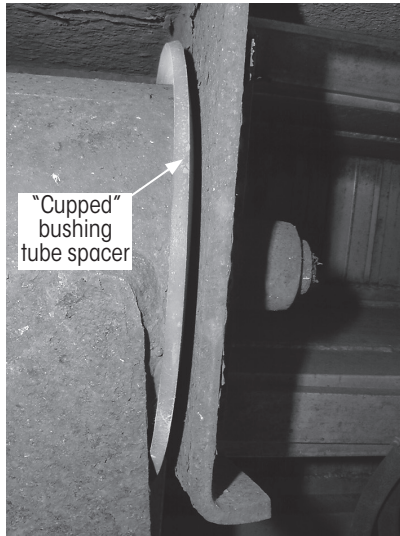

"WORN-THROUGH" — ABNORMAL

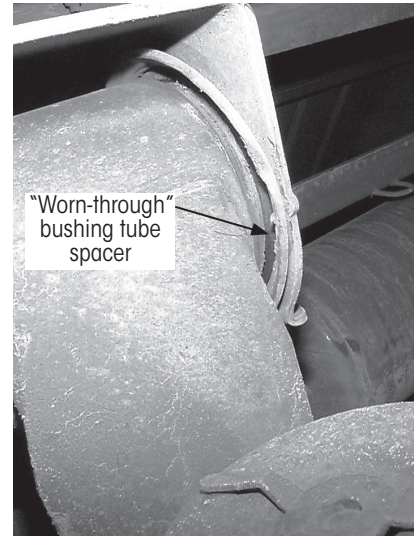

Normal bushing tube spacer in serviceable condition.



An example of a "cupped" bushing tube spacer. Friction-generated heat causes the spacer to "form" or "cup" around the bushing and bushing tube. This is normal and serviceable as long as the bushing tube spacer remains intact and does not become cut or worn-through.



Examples of "worn-through" bushing tube spacers. The spacer on the right is an example of extreme wear. Its circumference has been completely trimmed by the bushing tube. The spacer is not in serviceable condition.

Figure 2: Bushing tube spacer examples

Visually verify that the bushing tube spacers are intact and are not missing, cut, worn-through or otherwise deteriorated. Due to the pivoting motion inherent with this connection, some bushing tube spacer wear is expected (Figure 2). Bushing tube spacer "cupping", where the bushing tube spacer forms around the bushing tube and resembles a shallow dish, is also normal. If you see these conditions, no further inspection is required at this time. The bushing tube spacers are in serviceable condition.

However, a bushing tube spacer that is completely missing, has been cut or worn through is considered abnormal. If these conditions exist, a closer, more detailed inspection is required to prevent serious or costly problems and to prolong the life of the suspension.



EVALUATING BUSHING POSITION WITHIN THE BUSHING TUBE

NOTE: This procedure is not required if replacing the beam (HT™ Series suspensions) or HALFTRAAX™.

For evaluation purposes, the pivot bushing is considered either centered or off-center with respect to the bushing tube (Figure 3). The pivot bushing is considered off-center when a portion of the rubber extends outside of the bushing tube on one side and not on the other.

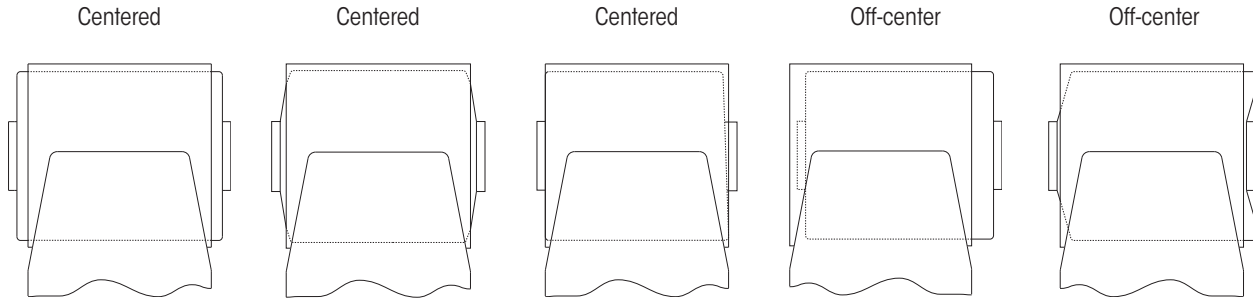

Figure 3: Typical examples of bushing position relative to the bushing tube (not representative of every possible case).

The key to identifying an off-center bushing is the bushing tube spacers. If the bushing tube spacers are in serviceable condition (not missing, cut, worn-through or otherwise deteriorated), the bushing cannot be off-center (Figure 3).

If the bushing is off-center, but the bushing tube width is acceptable, replace the bushing. Refer to Hendrickson literature number L427 *Bushing Replacement Procedure* for complete bushing replacement instructions.

IF BUSHING TUBE SPACER IS WORN THROUGH

If a missing, cut or otherwise worn through bushing tube spacer is discovered, the suspension pivot connection must be disassembled and the beam assembly lowered to check for potential beam and/or frame bracket wear (Figure 4). Refer to Hendrickson literature number L427 *Bushing Replacement Procedure* for complete pivot connection disassembly instructions.

⚠ CAUTION: Chock trailer wheels on the down axle, if available, and apply the trailer parking brakes so that it cannot move during disassembly. Follow local shop safety practices.

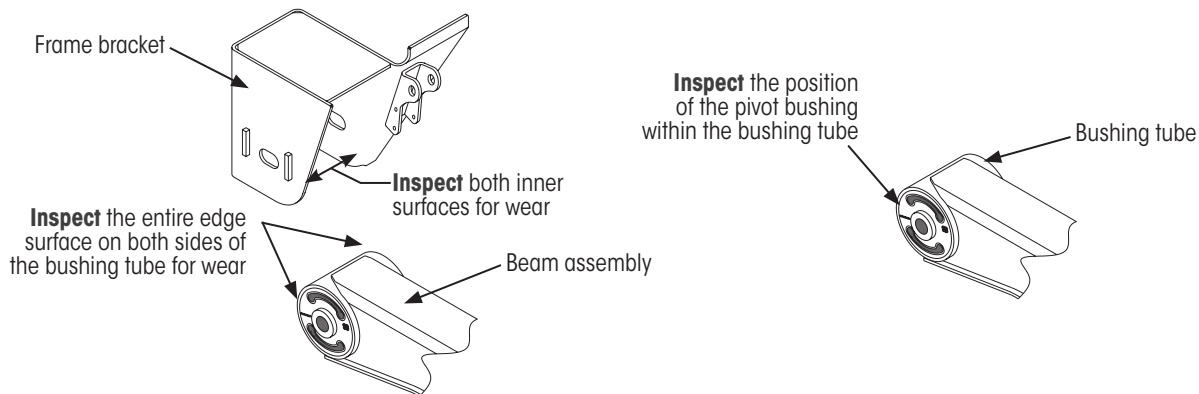

Figure 4: Pivot connection component inspection

With the beam assembly lowered (Figure 4), inspect inner surfaces of the frame bracket and edges of the bushing tube for wear. Also inspect the position of the pivot bushing within the bushing tube. The condition of these three areas will dictate the repair requirements or the necessity to replace any parts as instructed in [Table 2 on page 6](#).



EVALUATING FRAME BRACKET WEAR

With the beam assembly lowered (Figure 4), inspect the inner surfaces of the frame bracket. Some wear (polished metal) on the inner surface of the frame bracket is considered normal due to the pivoting motion inherent with this connection. Gouges or grooves worn into the frame bracket are abnormal. If any gouges, grooves or missing metal is found, the frame bracket must be replaced. For complete frame bracket replacement instructions, refer to applicable Hendrickson literature listed at the top of page 2.

After the frame bracket evaluation is complete. Continue with EVALUATING BUSHING TUBE WEAR.

EVALUATING BUSHING TUBE WEAR

Some wear (polished metal) on the edge of the bushing tube is considered normal (Figure 5) due to the pivoting motion inherent with this connection. Missing metal where the bushing tube's radius edge has been worn away is considered abnormal. If this type of wear is present, determine how much wear has occurred.

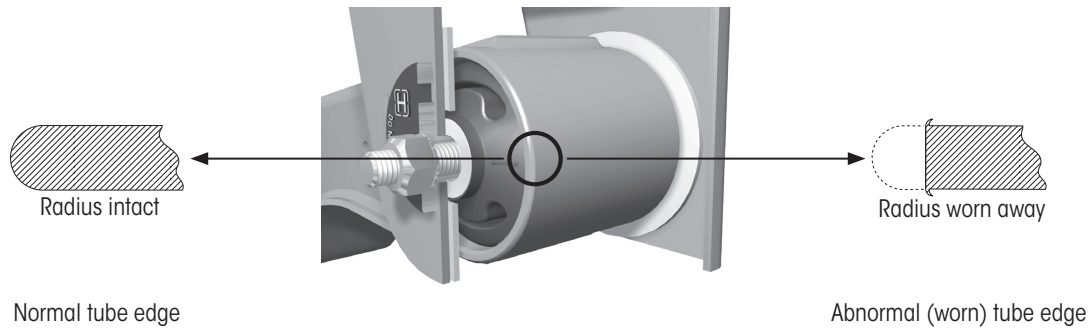
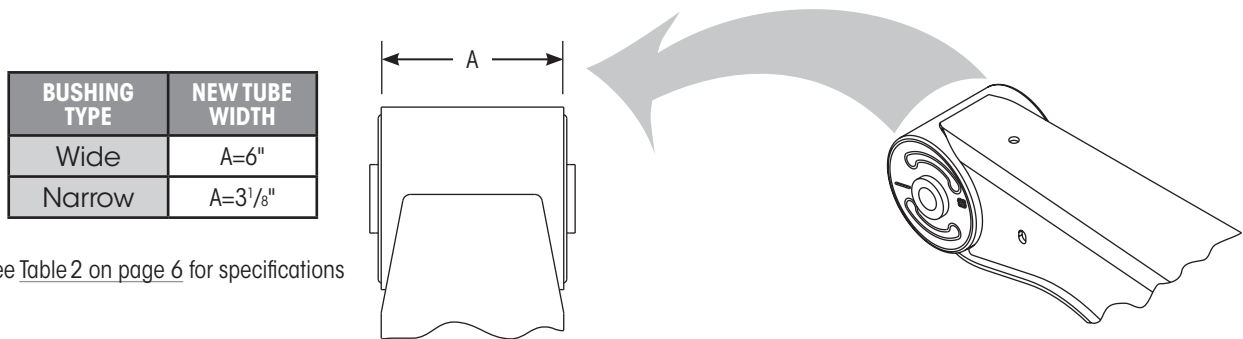

Figure 5: *Bushing tube edge wear (wide bushing)*

The amount of bushing tube wear can be determined by measuring the width of the worn bushing tube (Figure 6) and subtracting this measured dimension from the new tube width.



See Table 2 on page 6 for specifications

Figure 6: *Bushing tube width*

For example (wide bushing):

Suppose the inspection reveals extensive bushing tube wear and the bushing tube measures $5\frac{15}{16}$ inches. Subtracting $5\frac{15}{16}$ from 6 reveals the amount of bushing tube material that has worn away, in this case $\frac{1}{16}$ of an inch.

$$6'' - 5\frac{15}{16}'' = \frac{1}{16}''$$

Refer to the REPAIR RECOMMENDATIONS for repair procedures based on bushing tube width.



REPAIR RECOMMENDATIONS

Once each pivot connection component has been evaluated, and if bushing tube spacers are missing, cut or otherwise worn through; use the following table to determine the correct repair action. **DO NOT** add more bushing tube spacers than what is recommended in the table. A slight degree of freedom is required by the pivot bushing within the frame bracket to flex, elongate and otherwise absorb forces generated by braking, accelerating, turning and irregular road surfaces.

NOTICE: If more bushing tube spacers than what is recommended are added, the pivot bushing will not have enough room within the frame bracket to function properly and severe damage to the suspension could result.

IF THE BUSHING TUBE MEASURES:		AND THE BUSHING IS:	THEN:
Wide	Narrow		
5 ⁷ / ₈ to 6" (No wear on the bushing tube)	3 ¹ / ₈ ± ¹ / ₃₂ " (No wear on the bushing tube) ⁶	Centered ¹	Replace both bushing tube spacers and realign the axle. ^{2,5}
		Off-centered ^{2,3}	<ol style="list-style-type: none"> 1. Install new bushing. Refer to <u>L427 Bushing Replacement Procedure</u> for complete instructions. 2. Replace both bushing tube spacers and realign the axle.
5 ³ / ₄ " TO 5 ⁷ / ₈ " (Wear of 1/8" to 1/4" on the bushing tube)	N/A	N/A	<ol style="list-style-type: none"> 1. Remove existing bushing and dress the radius on the bushing tube edge according to the instructions in this document. 2. Install new bushing.⁴ Refer to <u>L427 Bushing Replacement Procedure</u> for complete instructions. 3. Replace both bushing tube spacers and realign the axle.
Less than 5 ³ / ₄ " (More than 1/4" wear on the bushing tube, Worn into the weld) ⁶	Less than 3 ³ / ₃₂ " (Worn into the weld) ⁶	N/A	<ol style="list-style-type: none"> 1. Replace the HALFTRAAX™ or the beam assembly. Refer to <u>L533 HALFTRAAX™ Axle and Beam Removal/Replacement Procedure</u> for complete HALFTRAAX replacement instructions for complete beam replacement instructions. 2. Replace both bushing tube spacers and realign the axle.

¹ Refer to the paragraph titled Figure 3 on page 4 for centered/off-center bushing definitions.
² Refer to Hendrickson literature number L579 Alignment Procedure for complete axle alignment instructions.
³ DO NOT attempt to center an off-center bushing (Figure 3). Remove the off-centered bushing and install a new one.
⁴ **Wide bushing only:** Install the new bushing from the worn side of the bushing tube. Refer to the paragraph titled REPLACEMENT BUSHING TUBE SPACER, WIDE BUSHING on page 8 for complete details.
⁵ Refer to the paragraph titled REPLACEMENT BUSHING TUBE SPACER, WIDE BUSHING on page 8 for installation details.
⁶ Any bushing tube wear into the weld is not acceptable. In this case, the axle/beam weldment (HALFTRAAX) will need to be replaced.

Table 2: Bushing tube measurement evaluation



BUSHING TUBE EDGE DRESSING

As described in [Table 2](#), it is acceptable to reuse the bushing tube if within the specifications listed in the table. However, the bushing tube edge must be dressed before the new bushing is installed. If not properly dressed, bushing tube and frame bracket components will wear more rapidly than normal.

Before attempting to install a new bushing, the worn bushing tube edge must be dressed. Use a grinder to re-establish a radius on the edge of the bushing tube as shown in [Figure 7](#) and defined in [Table 2](#).

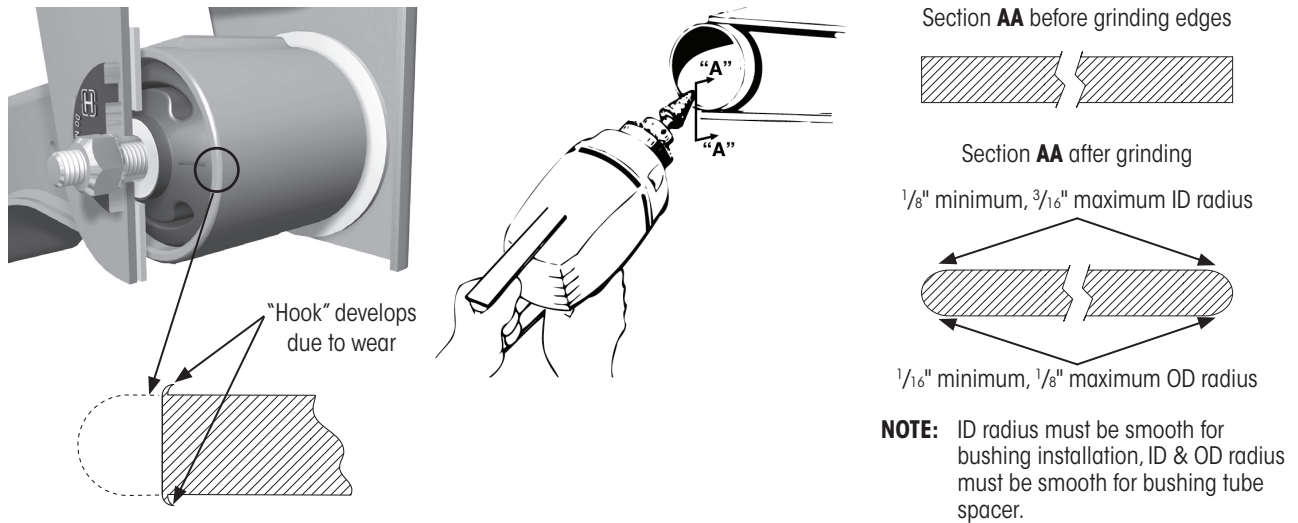

Figure 7: Repairing bushing tube edge

When the bushing tube wears, a slight “hook” or “tooth” of metal may develop on both inside and outside diameters of the tube ([Figure 7](#)). As the vehicle turns, the unique design of the pivot bushing allows it to elongate slightly to absorb the forces associated with road surface, load, etc. When the turn is complete and those particular forces are no longer present, the pivot bushing returns to its original position. If the “hook” or “tooth” on the bushing tube is not removed, it can “bite” into the rubber pivot bushing when elongated and hold or prevent it from returning to its original position, which is unacceptable. As this is repeated, the pivot bushing can eventually be pulled out of the bushing tube. The rubber pivot bushing may also become damaged by these irregular edges.

INSTALLING THE NEW BUSHING

The new bushing must be installed from the worn side of the bushing tube. If improperly installed, components will wear more rapidly than normal. Refer to Hendrickson literature number [L427 Bushing Replacement Procedure](#) for complete bushing tool and bushing replacement details.

⚠ CAUTION: After reassembly, remove wheel chocks and release the trailer parking brakes before moving the trailer.

REPLACEMENT BUSHING TUBE SPACER, WIDE BUSHING

When installing the replacement bushing tube spacers (part number S-21099), ensure the recessed side of each spacer faces the bushing tube as shown in [Figure 8](#).

NOTE: This information does not apply to narrow bushing tube spacers. Refer to [trailer parts catalogs](#); available online at www.hendrickson-intl.com/parts.

NOTE: Machined recess on S-21099 spacer must face toward the exposed surface of the bushing.

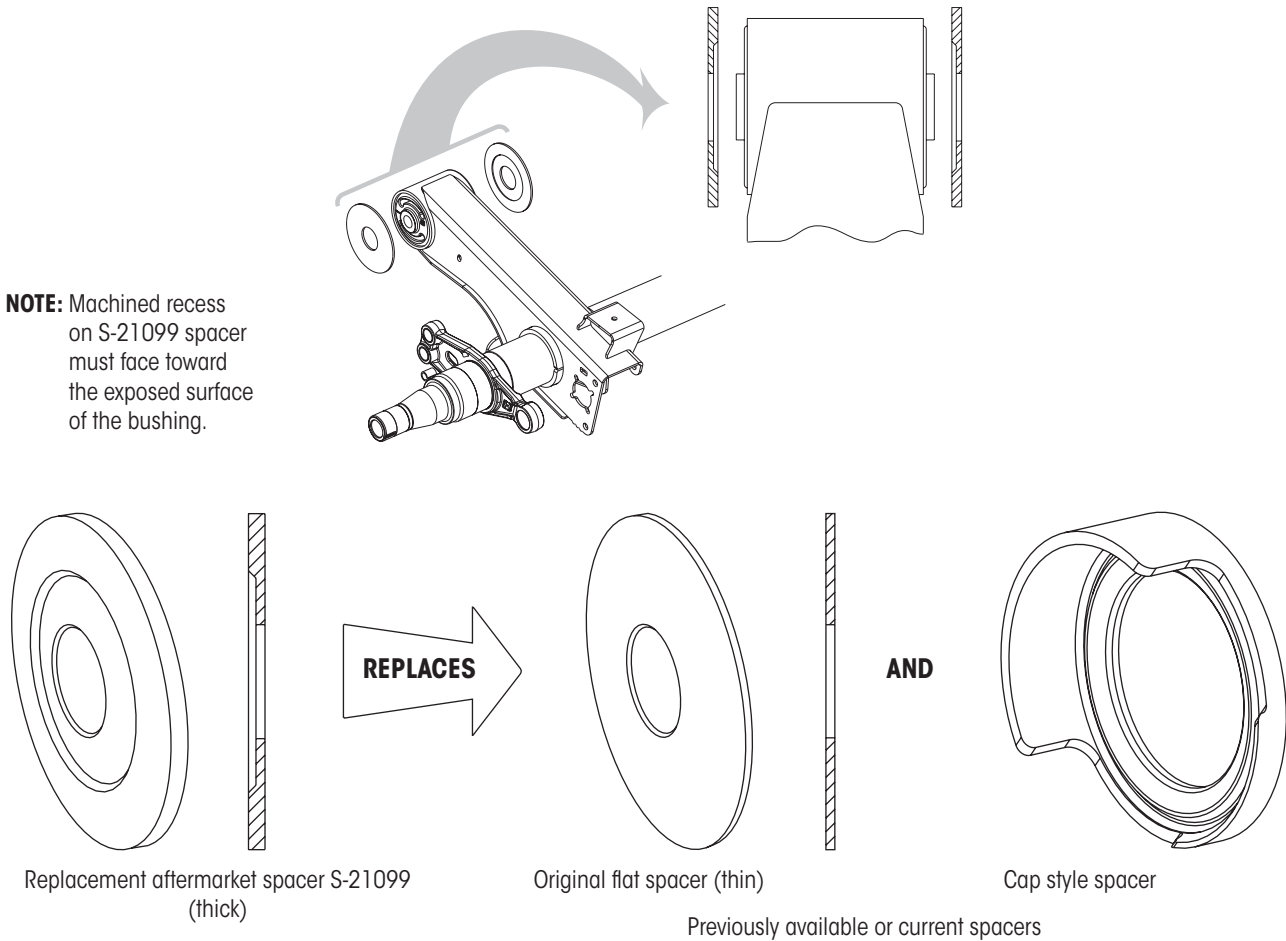

Figure 8: Bushing tube spacer orientation (wide bushing)

For additional technical support, contact **Hendrickson Trailer Technical Services**, in the United States and Canada at 866-RIDEAIR (743-3247) or email HTTS@Hendrickson-intl.com.

Call Hendrickson at **866.RIDEAIR (743.3247)** for additional information.



www.hendrickson-intl.com

TRAILER COMMERCIAL VEHICLE SYSTEMS

2070 Industrial Place SE
Canton, OH 44707-2641 USA
866.RIDEAIR (743.3247)
330.489.0045 • Fax 800.696.4416

Hendrickson Canada

250 Chrysler Drive, Unit #3
Brampton, ON Canada L6S 6B6
800.668.5360
905.789.1030 • Fax 905.789.1033

Hendrickson Mexicana

Circuito El Marqués Sur #29
Parque Industrial El Marqués
Pob. El Colorado, Municipio El Marqués,
Querétaro, México C.P. 76246
+52 (442) 296.3600 • Fax +52 (442) 296.3601