

HHN[®] SERIES VariRate[®] Spring System

- Maximize payload
- Maximize driver comfort
- Maximize durability

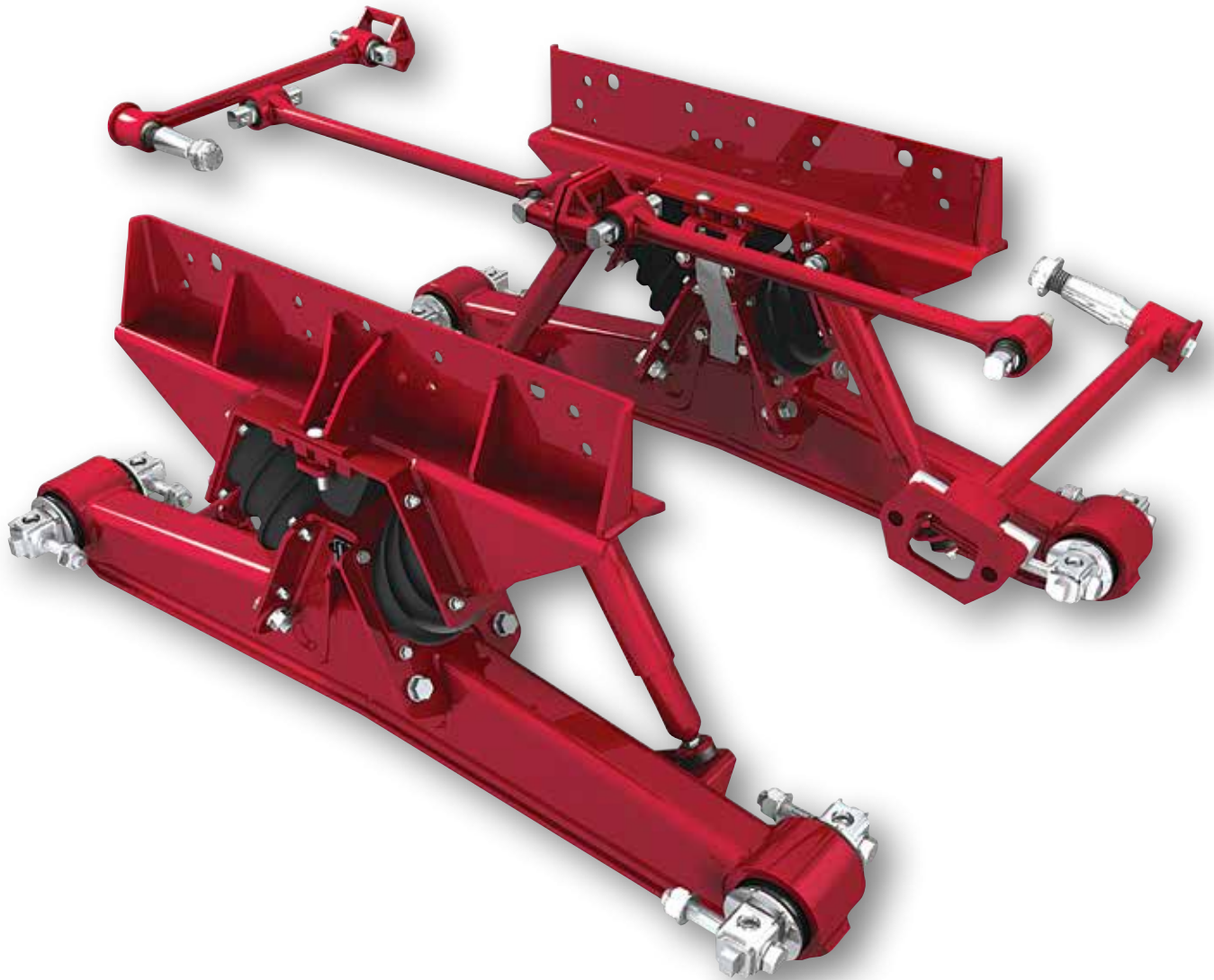

To learn more about HN Series
call 855.743.3733 or visit
www.hendrickson-intl.com

HHENDRICKSON
The World Rides On Us[®]

HN[®] SERIES

Lightweight for Increased Payload

VariRate[®] Spring System

- Delivers a combination of superior stability, articulation and ride

Rubber Bolster Springs

- Lightweight, diagonally-mounted rubber bolster springs deliver a smooth ride and outstanding articulation in empty or lightly loaded conditions
- Wide spring centers enhance stability and eliminate need for cross tube

Saddle

- Weight-saving, high-strength design increases payload capacity and durability

Genuine Hendrickson Torque Rods

- Improve cornering by controlling lateral forces
- Transverse rods ensure maximum lateral axle control and straight line suspension stability
- Longitudinal rods engineered to optimize resistance to wind up during acceleration and braking

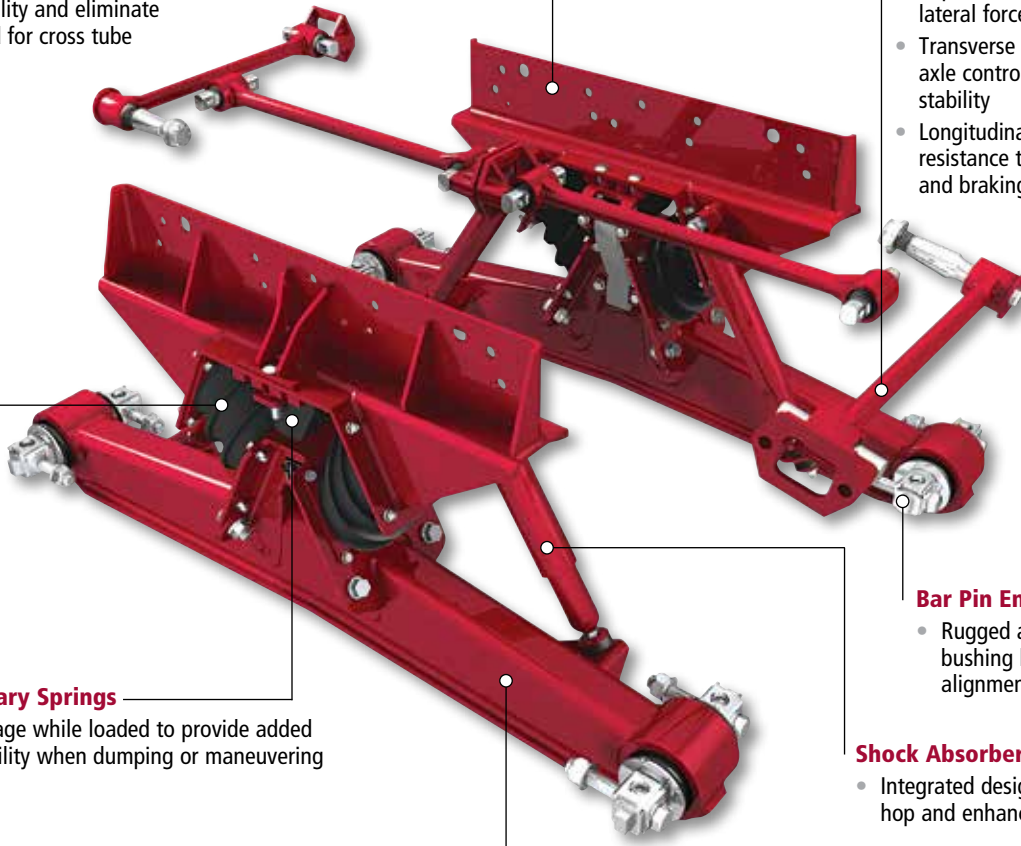

Auxiliary Springs

- Engage while loaded to provide added stability when dumping or maneuvering

Bar Pin End Connection

- Rugged axle connection extends bushing life and allows easy axle alignment and serviceability

Shock Absorbers

- Integrated design reduces axle hop and enhances ride quality

Equalizing Beam

- Formed and robotically-welded beam provides a narrow profile for weight savings
- Distributes load equally between both axles for improved traction
- Lowers center of gravity to increase stability
- Establishes a solid axle connection for improved handling
- Center bushing eliminated for reduced maintenance

46,000 lbs. Weight Comparison*

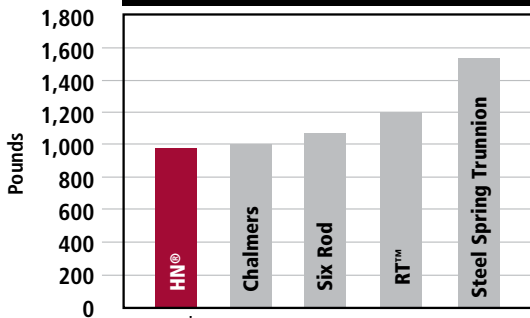

*OEM databook weights may vary.

Weight includes the suspension system and related components. Data is based on internal testing and / or published specifications. Actual product specifications and performance may vary depending upon suspension and vehicle configuration, operation, service and other factors.

Maximize Driver Comfort and Confidence

The heart of the HN® Series suspension is the VariRate® spring system. In the empty or lightly loaded condition, the unique diagonally-mounted rubber bolster springs deliver superior ride quality. Extra wide spring centers and auxiliary springs provide exceptional stability for demanding applications such as refuse trucks, concrete mixers and dumps. Here's how it works:



Unloaded Condition

Diagonally-mounted rubber bolster springs act in compression and shear to provide optimum spring deflection for outstanding ride quality.

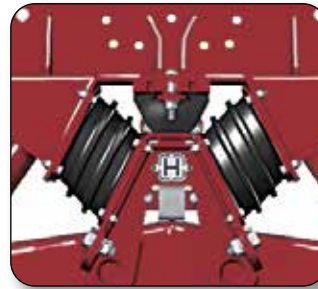

Loaded Condition

As payload increases, the bolster springs compress and increase in stiffness, while maintaining excellent ride quality. When loaded, the auxiliary spring engages to provide additional stability.

Maximize Ride and Stability

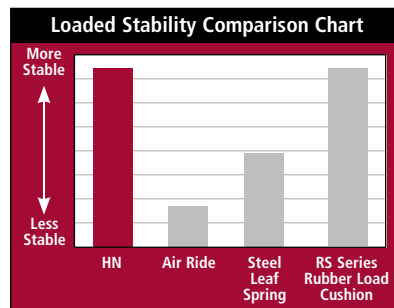
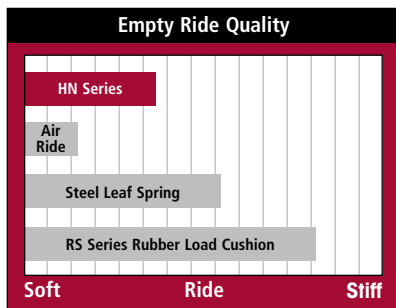

Combining empty ride quality with loaded stability, Hendrickson's VariRate Spring System outperforms other suspension systems.

Data is based upon internal testing and / or published specifications. Actual product specifications and performance may vary depending upon suspension and vehicle configuration, operation, service and other factors.

Maximize Uptime

Reduced Maintenance Through Advanced Design

- The robotically-welded equalizing beam design eliminates center bushings and lubrication requirements, significantly reducing scheduled maintenance.
- Hendrickson's unique bar pin beam end connection extends service life and offers axle alignment capability for accurate wheel tracking and improved tire life.
- Hendrickson's unique bonded torque rod bushings greatly increase service life. By eliminating the outer metal sleeve, Hendrickson made rebushing faster and easier.
- Hendrickson parts are available at thousands of service locations worldwide.



Bar Pin End Connection

Maximize Traction

Excellent Traction for Outstanding Off-Road Mobility

The HN Series unique combination of equalizing beam and VariRate technology provides excellent traction on punishing job sites. When loaded, HN suspensions allow 17 inches* of diagonal wheel articulation to keep load on all drive wheels. Unloaded articulation varies with vehicle configuration and empty body weight.



* Suspension articulation may exceed vehicle's capability and may be limited by vehicle manufacturer; vehicle manufacturer installed axle stops may restrict suspension's articulation.

HN® SERIES Specifications

	HN 402	HN 462	HN 522
Installed Weight ¹ (54-in. axle spacing)	935 lbs.	948 lbs.	955 lbs.
Suspension Rating	40,000 lbs.	46,000 lbs.	52,000 lbs.
GVW Approval ²	73,000 lbs.	80,000 lbs.	80,000 lbs.
GCW Approval	160,000 lbs.	190,000 lbs.	245,000 lbs.
Site Travel Rating ³	55,000 lbs.	60,000 lbs.	65,000 lbs.
Diagonal Articulation ⁴	17 inches	17 inches	17 inches
Lift Axles	Approved	Approved	Approved
Axle Spacing	52, 54, 60, 72.5 inches	54, 60, 72.5 inches	54, 60 inches
Wheel Base Restrictions	None	None	None

HN® Series suspensions are intended for a wide range of applications, including dump, refuse, mixer and logging. All such applications must comply with applicable Hendrickson specifications and must also be approved by the respective vehicle manufacturer with the vehicle in its original, as-built configuration. Contact Hendrickson and the respective vehicle manufacturer for approval of additional applications.

A variant of the HN system called HN FR is available for fire and rescue applications. Please see Hendrickson literature number 45745-318 for further details regarding the HN FR system. If you have any questions, contact Hendrickson or your local truck dealer.

- ¹ Installed weight includes complete suspension, torque rods, axle brackets, shock absorbers and frame brackets.
- ² Contact Hendrickson for applications that may exceed GVW approval ratings.
- ³ Site Travel Rating — Operators using vehicles equipped with liftable pusher or tag axles must not exceed published ratings. Ratings are limited to no more than 5 percent of vehicle operation at speed not to exceed 5 mph. Liftable pusher or tag axles should only be raised (or unloaded) to improve vehicle maneuverability in off-road use or when vehicle is empty. Site travel ratings are consistent with published axle manufacturer's limitations. Axle and suspension site travel specifications must not be exceeded.
- ⁴ Suspension articulation may exceed vehicle's capability and may be limited by vehicle manufacturer; vehicle manufacturer installed axle stops may restrict suspension's articulation.

Actual product specifications and performance may vary depending upon suspension and vehicle configuration, operation, service and other factors.

Hendrickson Genuine Parts are the same quality components installed in Hendrickson original equipment suspensions — consisting of the same design, construction, performance and durability. There's only one way to maintain and protect your suspension's original performance. Ask for the name that is synonymous with the finest manufactured suspensions in the world.

Extended Warranty options available at www.hendrickson-intl.com

Actual product performance may vary depending upon vehicle configuration, operation, service and other factors.

All applications must comply with applicable Hendrickson specifications and must be approved by the respective vehicle manufacturer with the vehicle in its original, as-built configuration. Contact Hendrickson for additional details regarding specifications, applications, capacities, and operation, service and maintenance instructions.

Call Hendrickson at **630.910.2800** or **855.RIDERED (743.3733)** for additional information.



TRUCK COMMERCIAL VEHICLE SYSTEMS

800 South Frontage Road
Woodridge, IL 60517-4904 USA
855.RIDERED (743.3733)
630.910.2800 • Fax 630.910.2899

www.hendrickson-intl.com

45745-087 Rev K 05-20

© 2006 - 2020 Hendrickson USA, L.L.C. All Rights Reserved. All trademarks shown are owned by Hendrickson USA, L.L.C., or one of its affiliates, in one or more countries. Information contained in this literature was accurate at the time of publication. Product changes may have been made after the copyright date that are not reflected.

Printed in United States of America