

H PARTS LIST

VANTRAAX® HKANT 46K/

HKAT 46K/HKA200

LIT NO: L890

DATE: May 2019

REVISION: I





SLIDER BOX ASSEMBLY

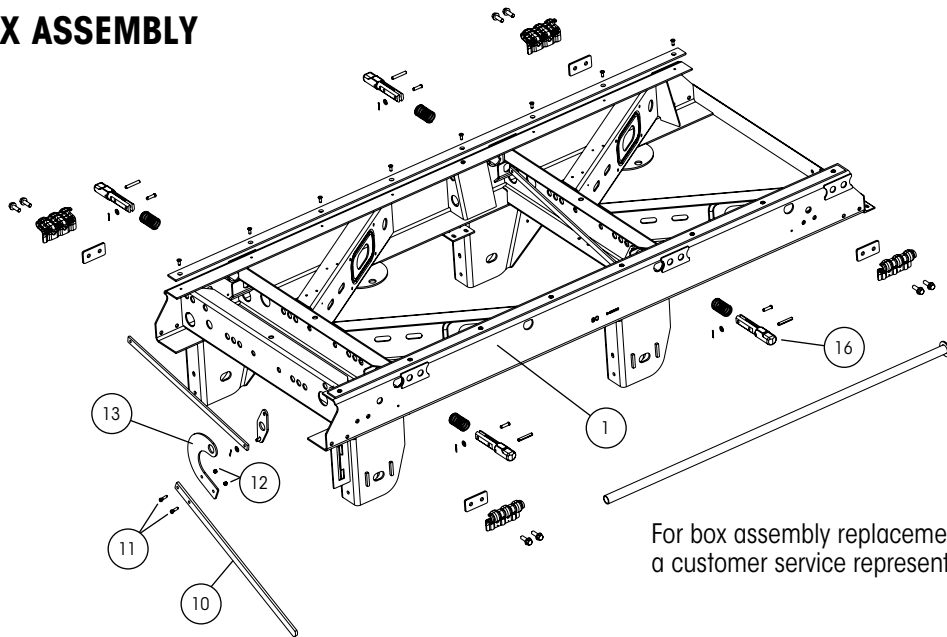

For box assembly replacement, contact a customer service representative.

SLIDER PINS

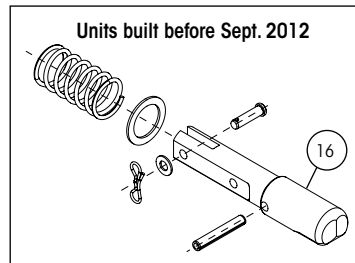
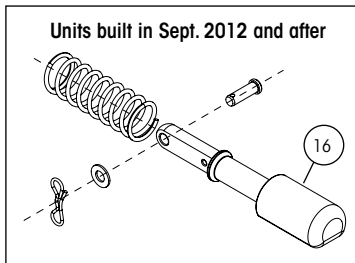

QUIK-DRAW® ACTUATOR ENDS

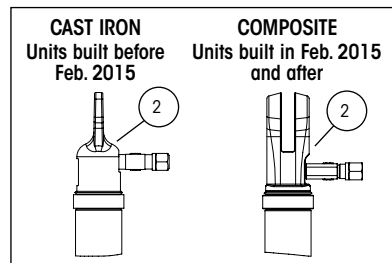

RELEASE MECHANISMS

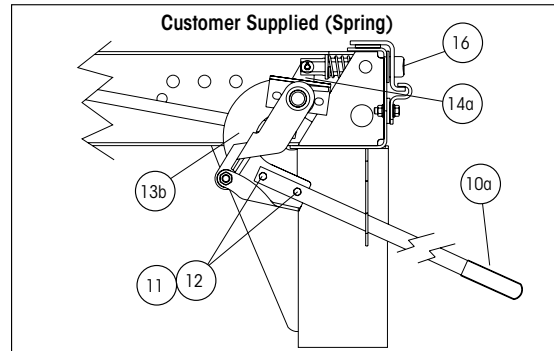
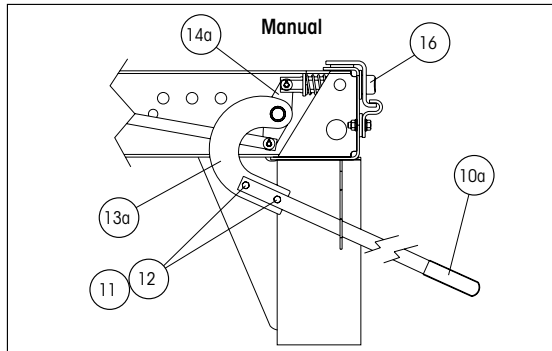

NO LONGER AVAILABLE ON PRODUCTION MODELS OR BOX REPLACEMENTS — PARTS FOR THESE MECHANISMS ARE STILL AVAILABLE

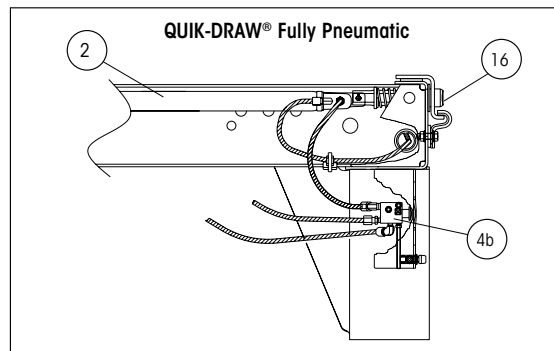
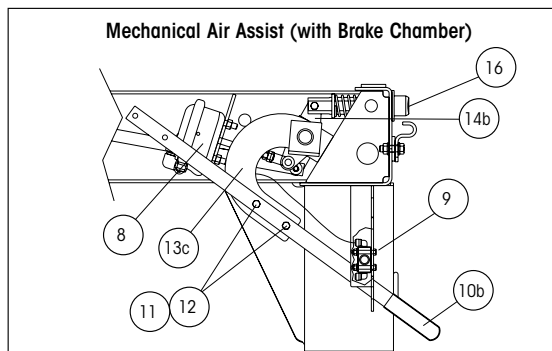

**SLIDER BOX ASSEMBLY**

ITEM	DESCRIPTION	PART NO.	SYSTEM	
			QTY.	NOTE
1	AFTERMARKET BOX REPLACEMENT	AMBOX.###		Contact Hendrickson for assistance
2	QUIK-DRAW® PNEUMATIC PIN-PULL MECHANISM			See L751 QUIK-DRAW Parts List
3	PIN EXTENSION 54" BOX WIDTH (Not shown)			See L751 QUIK-DRAW Parts List
4	QUIK-DRAW VALVE			See L751 QUIK-DRAW Parts List
5	QUIK-DRAW VALVE KNOB with SET SCREW (Not shown)			See L751 QUIK-DRAW Parts List
6	QUIK-DRAW VALVE SPACER (Not shown)			See L751 QUIK-DRAW Parts List
7	QUIK-DRAW RETROFIT KIT (Not shown)			See L751 QUIK-DRAW Parts List
8	BRAKE CHAMBER MECHANICAL AIR ASSIST	A-23039	1	Type 12 modified
9	AIR VALVE MECHANICAL AIR ASSIST	VS-23224	1	Air valve with fittings
10	HANDLE ASSEMBLY			
	10a Manual and customer supplied release mechanisms	S-25592	1	Handle and grip assembly
	10b Mechanical air assist release mechanisms	B-22923	1	Handle only
11	HANDLE BOLT	SA-1100-10	2	2-3/8"-16 × 1-1/4" hex head bolt, grade 5
12	HANDLE NUT	SA-9000-5	2	2-3/8"-16 lock nut, grade B
13	HANDLE MOUNT			
	13a Manual	C-21275	1	
	13b Customer supplied	S-23534	1	Includes crank arm bolt kit
	13c Mechanical air assist	C-23231	1	
14	CRANK ARM WELDMENT			
	14a Manual and customer supplied	B-33010	2	For front and rear of slider box
	14b Mechanical air assist	B-33010	1	For rear of slider box
15	CRANK ARM BOLT KIT (Not shown)	A-22041	1	Includes bolt, flat washer, lock washer and nut
16	LOCKING PIN			See L751 QUIK-DRAW Parts List

Note: Narrow hanger shown. Pin pull mechanisms are identical for both wide and narrow width slider models.

Note: Identification can be found on the roadside slider box rail above the front frame bracket there will also be a blank INTRAAX® tag on the inside of the curbside beam



SLIDER BOX ASSEMBLY

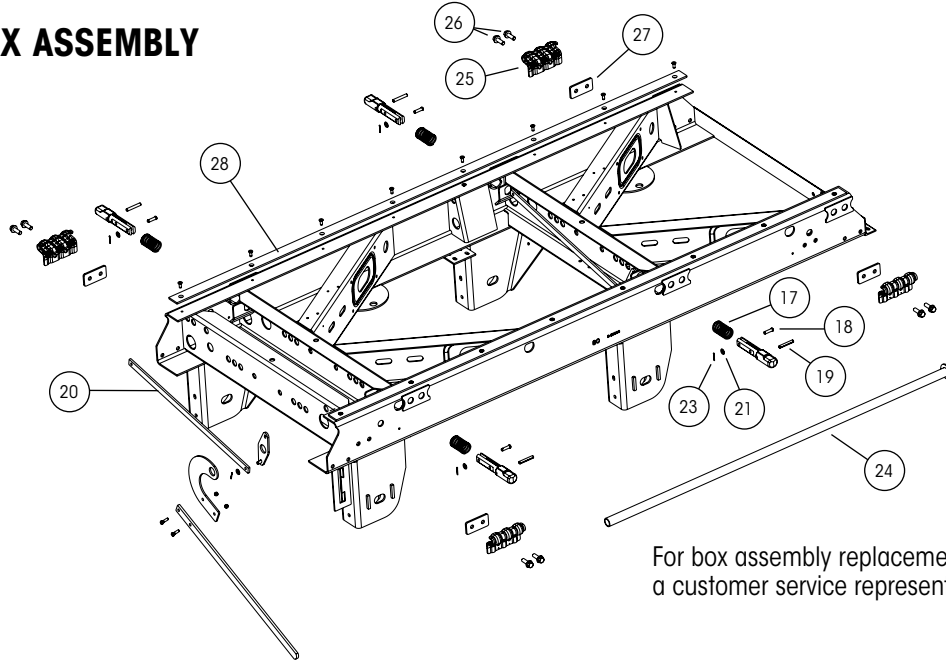

For box assembly replacement, contact a customer service representative.

SLIDER PINS

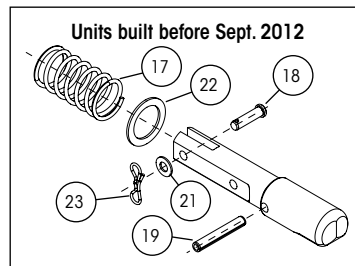
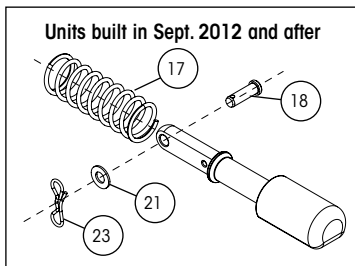

QUIK-DRAW® ACTUATOR ENDS

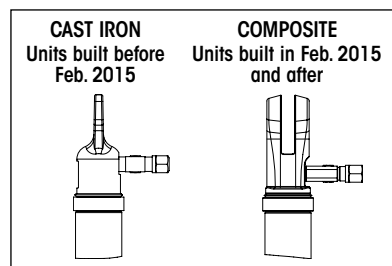

RELEASE MECHANISMS

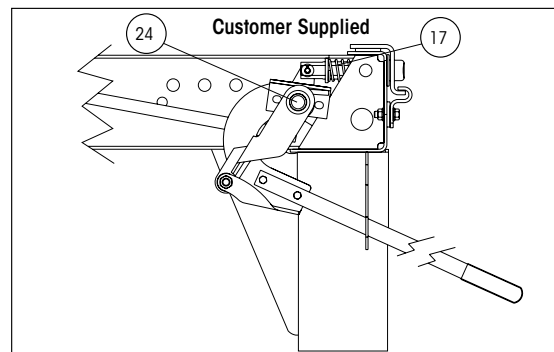
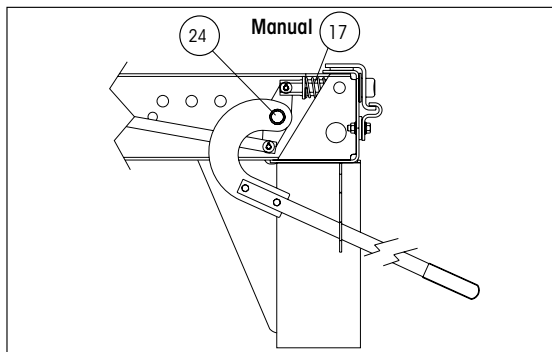

NO LONGER AVAILABLE ON PRODUCTION MODELS OR BOX REPLACEMENTS — PARTS FOR THESE MECHANISMS ARE STILL AVAILABLE

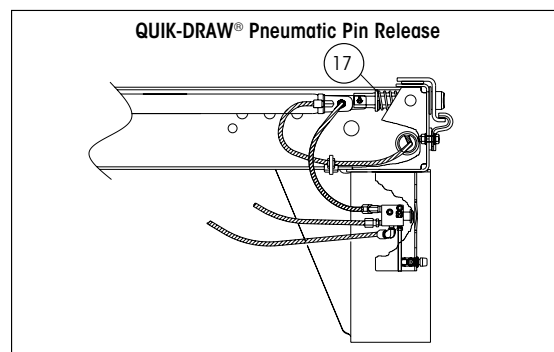
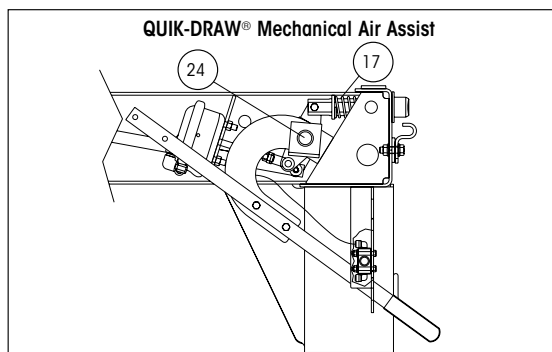

**SLIDER BOX ASSEMBLY**

ITEM	DESCRIPTION	PART NO.	SYSTEM QTY.	NOTE
17	LOCKING PIN SPRING			See L751 QUIK-DRAW® Parts List
18	CLEVIS PIN			See L751 QUIK-DRAW Parts List
19	SPRING PIN (Units built before Sept. 2012)			See L751 QUIK-DRAW Parts List
20	LOCKING PIN LINK			See L751 QUIK-DRAW Parts List
21	LOCKING PIN WASHER			See L751 QUIK-DRAW Parts List
22	PIN WASHER (Units built before Sept. 2012)			See L751 QUIK-DRAW Parts List
23	LOCKING PIN LINK COTTER PIN			See L751 QUIK-DRAW Parts List
24	PIPE WELDMENT			
	Manual and mechanical air assist	S-21433	1	
	Customer supplied	S-21433-1	1	
25	BODY RAIL CLIP			
	3.4" clip height	S-24459	4	Use with 4" hole centers and 1.625" locking pin
	3.8" clip height	S-24460	4	Use with 6" hole centers and 1.395" locking pin
26	BODY RAIL CLIP BOLT	SA-6900-2	8	1/2"-13" x 1-1/2" flanged bolt
27	BODY RAIL CLIP SPACER	A-22367	4	2" clip hole centers
28	SLIDER WEAR PAD KIT	S-14342-3	2	Includes (1) slider wear pad and (8) screws



SUSPENSION ASSEMBLIES

HKANT 46K - Narrow Bushing / Tapered Beam Model

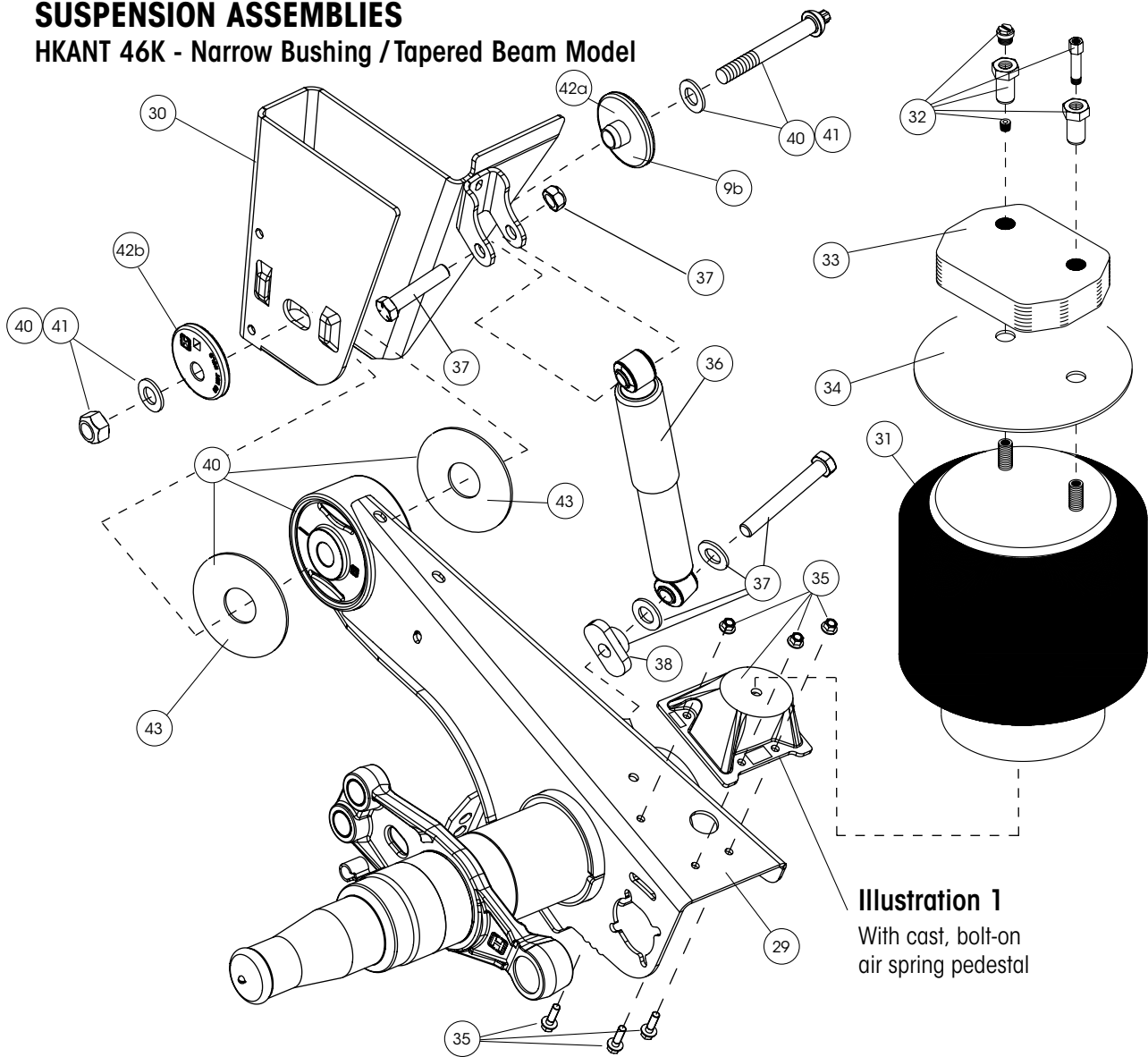

Illustration 1
With cast, bolt-on
air spring pedestal

Manufactured Late August 2002 Through 2008

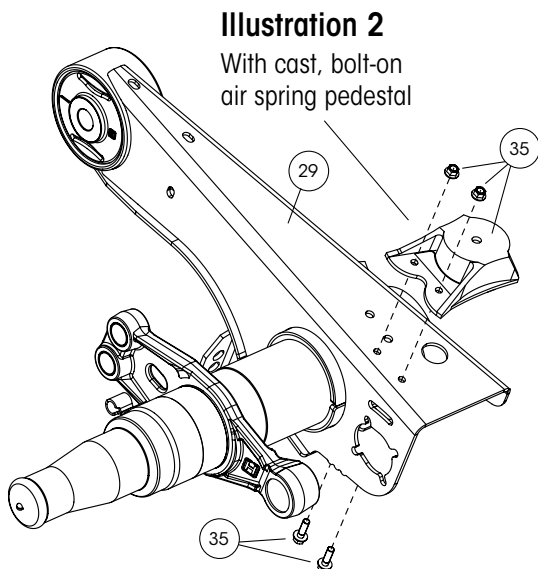

Illustration 2
With cast, bolt-on
air spring pedestal

Manufactured 2001 Through 2002

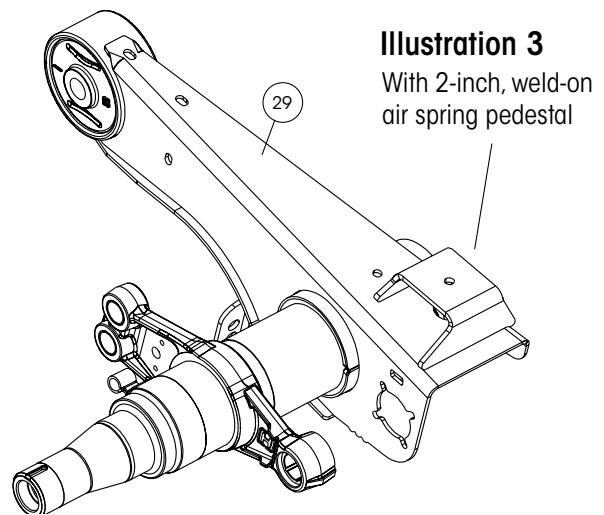

Illustration 3
With 2-inch, weld-on
air spring pedestal

**SUSPENSION ASSEMBLIES —****HKANT 46K - Narrow Bushing / Tapered Beam Model**

ITEM	DESCRIPTION	PART NO.	SYSTEM QTY.	NOTE
29	HALFTRAAX™ AXLE/BEAM WELDMENT	HTRAAX.###	2	Contact Hendrickson for assistance
30	FRAME BRACKET			See L1266 Frame Bracket Parts List
31	AIR SPRING			
	16" ride height and above	S-22948	4	Replaces C-21966
	Below 16" ride height	S-21800	4	Replaces C-21800
32	AIR SPRING MOUNTING KIT (per air spring) - When model includes a cast, bolt-on pedestal under the air spring.			
	14" - 18" ride heights	S-22619/2	4	Includes Spiralock nuts, pipe plug and flange nut
	19" ride height	S-22630/2	4	Includes Spiralock nuts, pipe plug, air fitting and flange nut
33	AIR SPRING SPACER - When model includes a cast, bolt-on pedestal under the air spring.			19" ride height
		B-22510-1	4	1-1/8" spacer
34	AIR SPRING MOUNTING PLATE	S-27042	4	15.5" ride height
35	CAST AIR SPRING PEDESTAL KIT - When model includes a cast, bolt-on pedestal under the air spring. (Illustrations 1 and 2)			
	16" ride height with 2" pedestal	S-27447-1	2	Includes left and right side pedestals and fasteners
	16.5" ride height with 2.57" pedestal	S-27447-2	2	Same as above
	14" and 17" ride heights with 3.17" pedestal	S-27447-3	2	Same as above
	15", 15.5", 18" and 19" ride heights with 3.91" pedestal	S-27447-4	2	Same as above
36	SHOCK ABSORBER	S-23566	4	Standard duty
37	SHOCK BOLT KIT	S-24049/2	4	Includes shear bolt, spacer, washers, hex bolt and hex nut
38	SHOCK SPACER	S-27196	4	
39	SHOCK STRAP KIT (Not shown)	C-23086-1	4	Includes (2) straps, (2) clevis and (4) ties
40	TRI-FUNCTIONAL® PIVOT BUSHING KIT ¹	S-26321	2	Narrow bushing, includes (2) bushings, (2) pivot bolt kits, (4) bushing tube spacers and lubricant pack
41	QUIK-ALIGN® PIVOT BOLT KIT	S-24705	4	Contains 7" bolt, nut and hardened washers
42	QUIK-ALIGN ALIGNMENT COLLAR			
	42a Concentric (inner)	S-20924	4	Pivot bolt hole is centered
	42b Eccentric (outer)	S-20925	4	Pivot bolt hole is offset from center
43	BUSHING TUBE SPACER	S-26807	8	Outer diameter dimension of TRI-FUNCTIONAL bushing inner metal is 2.6"; inner hole dimension of bushing tube spacer 2.95"

1. Bushing tool S-24736 is required to correctly re-bush the suspension.

Note: Identification can be found on the roadside slider box rail above the front frame bracket there will also be a blank INTRAAX tag on the inside of the curbside beam.



**SUSPENSION ASSEMBLIES —
HKAT 46K / HKA200 - Wide Bushing / Straight Beam Model**

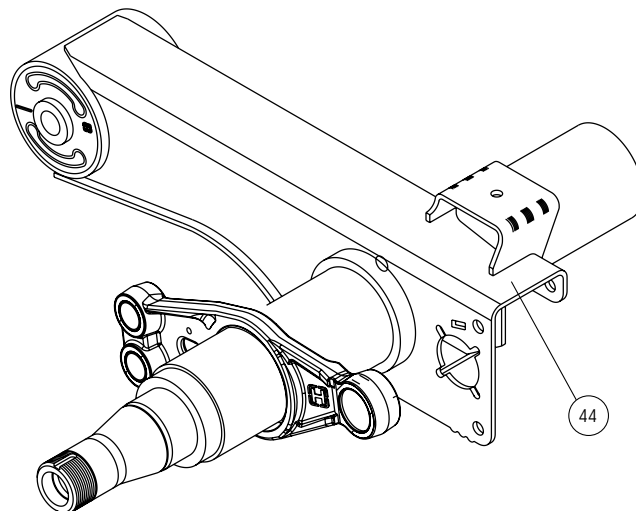
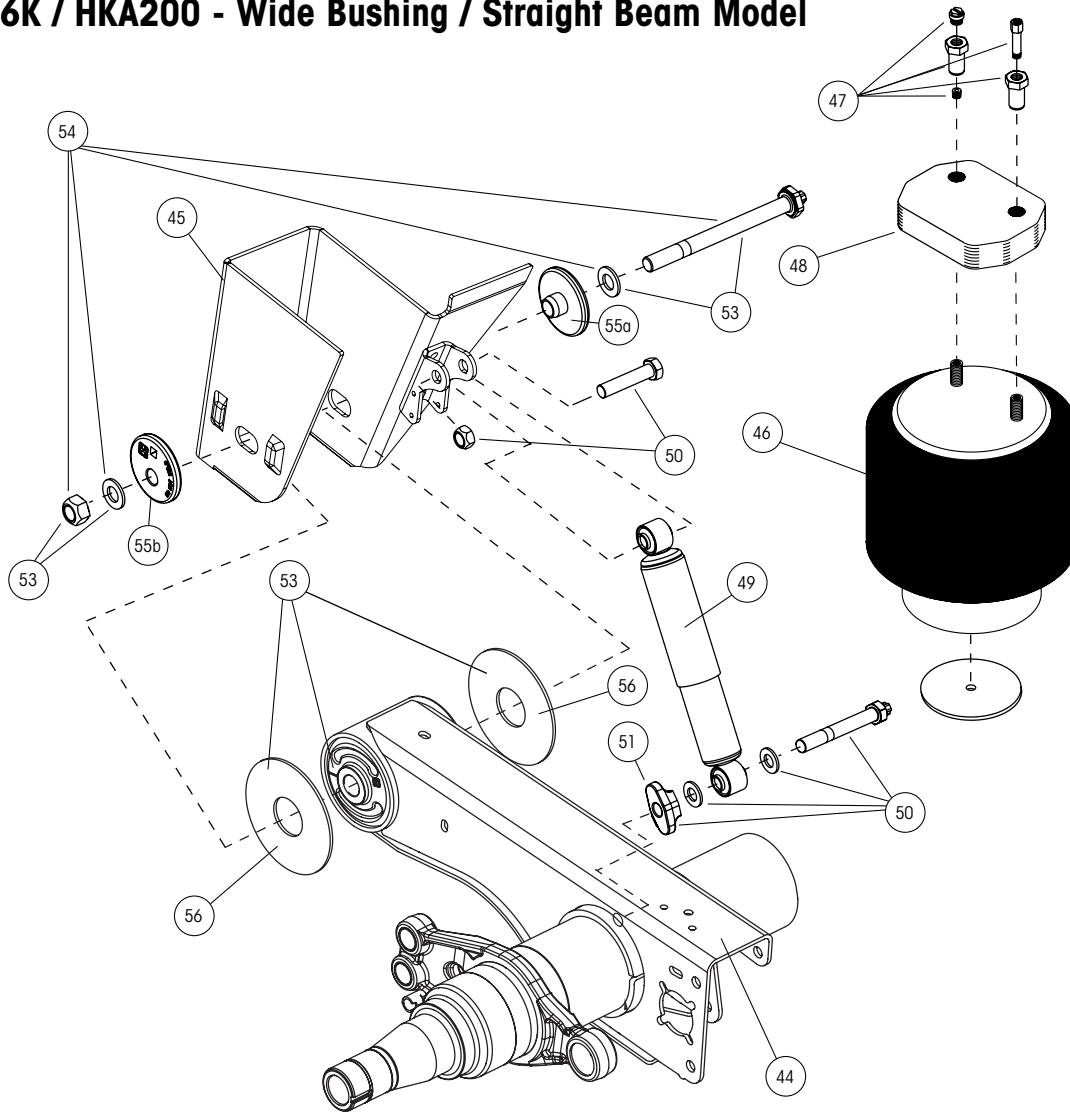



SUSPENSION ASSEMBLIES — HKAT 46K / HKA200 - Wide Bushing / Straight Beam Model

ITEM	DESCRIPTION	PART NO.	SYSTEM QTY.	NOTE
44	HALFTRAAX™ AXLE/BEAM WELDMENT	HTRAAX.###	2	Contact Hendrickson for assistance
45	FRAME BRACKET ASSEMBLY			See L1266 Frame Bracket Parts List
46	AIR SPRING			
	14" - 15" ride heights	S-21800	4	Replaces C-21800
	16" - 19" ride heights	S-22948	4	Replaces C-21966
47	AIR SPRING MOUNTING KIT (per air spring) - When model includes a 2", weld-on pedestal under the air spring.			
	14" and 16.5" ride heights	S-22635/2	4	Includes Spiralock nuts, pipe plug and flange nut
	16" ride height	S-22619/2	4	Same as above
	15" and 18" ride heights	S-22631/2	4	Includes Spiralock nuts, pipe plug, air fitting and flange nut
	17" ride height	S-22630/2	4	Same as above
	19" ride height	S-22632/2	4	Same as above
48	AIR SPRING SPACER - When model includes a 2", weld-on pedestal under the air spring.			
	14" and 16.5" ride heights	B-22510-4	4	3/4" spacer
	15" and 18" ride heights	B-22510-2	4	1-7/8" spacer
	17" ride height	B-22510-1	4	1-1/8" spacer
	19" ride height	B-22510-3	4	3-1/8" spacer
49	SHOCK ABSORBER	S-23566	4	Standard duty
50	SHOCK BOLT KIT	S-24049/2	4	Includes shear bolt, spacer, washers, hex bolt and hex nut
51	SHOCK SPACER	S-27196	4	
52	SHOCK STRAP KIT (Not shown)	C-23086-1	4	Includes (2) straps, (2) clevis and (4) ties
53	TRI-FUNCTIONAL® PIVOT BUSHING KIT ¹	S-24691	4	Wide bushing, includes (1) bushing, (1) pivot bolt kit, (2) bushing tube spacers and lubricant pack
54	QUIK-ALIGN® PIVOT BOLT KIT	S-24679	4	Contains 10" bolt, nut and hardened washers
55	QUIK-ALIGN ALIGNMENT COLLAR			
	55a Concentric (inner)	S-20924	4	Pivot bolt hole is centered
	55b Eccentric (outer)	S-20925	4	Pivot bolt hole is offset from center
56	BUSHING TUBE SPACER	S-21099	8	Outer diameter dimension of TRI-FUNCTIONAL Bushing inner-metal is 2.2"; Inner hole dimension of bushing tube spacer 2.38"

1. Bushing tool S-21307 is required to correctly re-bush the suspension

Note: Identification can be found on the roadside slider box rail above the front frame bracket there will also be a blank INTRAAX tag on the inside of the curbside beam



OTHER PARTS LISTS

More information can be found in the following documents

Lit. Number	Description
L1055	SURELOK® Parts List
L1102	Slider Accessories and Axle Components Parts List
L949	RTR® READY-TO-ROLL® Parts List
L589	TRI-FUNCTIONAL® Bushing Replacement Tool
L1063	Air Disc Brakes Parts List
L1104	Brake Kits and Components Parts List

NOTES



NOTES

*Actual product performance may vary depending upon vehicle configuration, operation, service and other factors.
All applications must comply with applicable Hendrickson specifications and must be approved by the respective vehicle manufacturer with the vehicle in its original, as-built configuration.
Contact Hendrickson for additional details regarding specifications, applications, capacities, and operation, service and maintenance instructions.*

Call Hendrickson at 330.489.0045 or 866.RIDEAIR (743.3247) for additional information.



www.hendrickson-intl.com

TRAILER COMMERCIAL VEHICLE SYSTEMS

2070 Industrial Place SE
Canton, OH 44707-2641 USA
866.RIDEAIR (743.3247)
330.489.0045 • Fax 800.696.4416

Hendrickson Canada

250 Chrysler Drive, Unit #3
Brampton, ON Canada L6S 6B6
800.668.5360
905.789.1030 • Fax 905.789.1033

Hendrickson Mexicana

Circuito El Marqués Sur #29
Parque Industrial El Marqués
Pob. El Colorado, Municipio El Marqués,
Querétaro, México C.P. 76246
+52 (442) 296.3600 • Fax +52 (442) 296.3601

L890 Rev I 05-19

© 2009 – 2019 Hendrickson USA, L.L.C. All Rights Reserved. All trademarks shown are owned by Hendrickson USA, L.L.C., or one of its affiliates, in one or more countries.
Information contained in this literature was accurate at the time of publication. Product changes may have been made after the copyright date that are not reflected.

Printed in United States of America