

H PARTS LIST

STEERTEK™ NXT High Capacity Steer Axle System for KME Fire/Rescue Vehicles

LIT NO: SP-305

DATE: December 2018

REVISION: A

CONTENTS

DESCRIPTION	PAGE	DESCRIPTION	PAGE
Parts Lists		Selection Guides	6
■ Suspension • Axle • Clamp Group Assembly	2	Special Tool	6
■ Disc Brake Assembly	4		
■ Drum Brake Assembly	5		

STEERTEK™ NXT High Capacity
with Air Disc Brakes

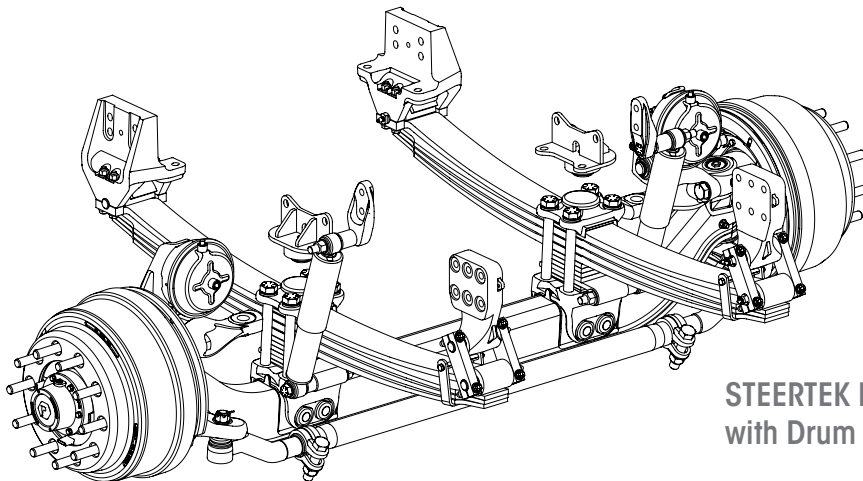
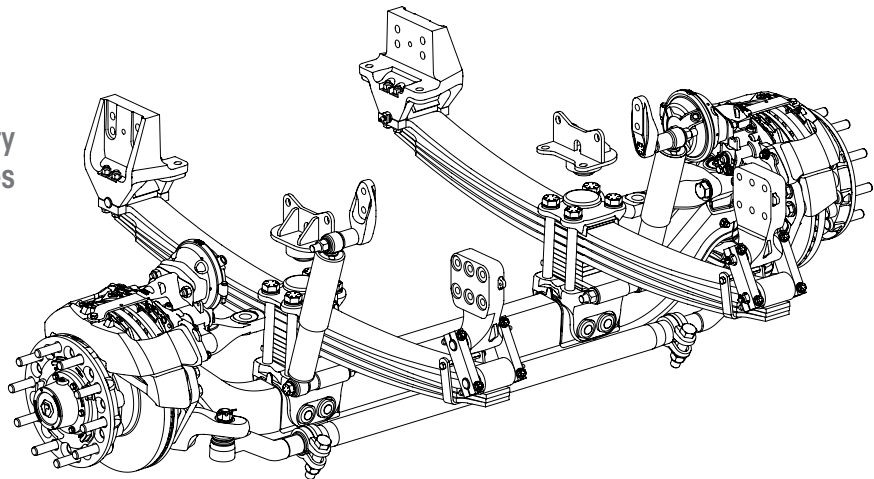

STEERTEK NXT High Capacity
with Drum Brakes



Suspension • Clamp Group • Axle Assembly

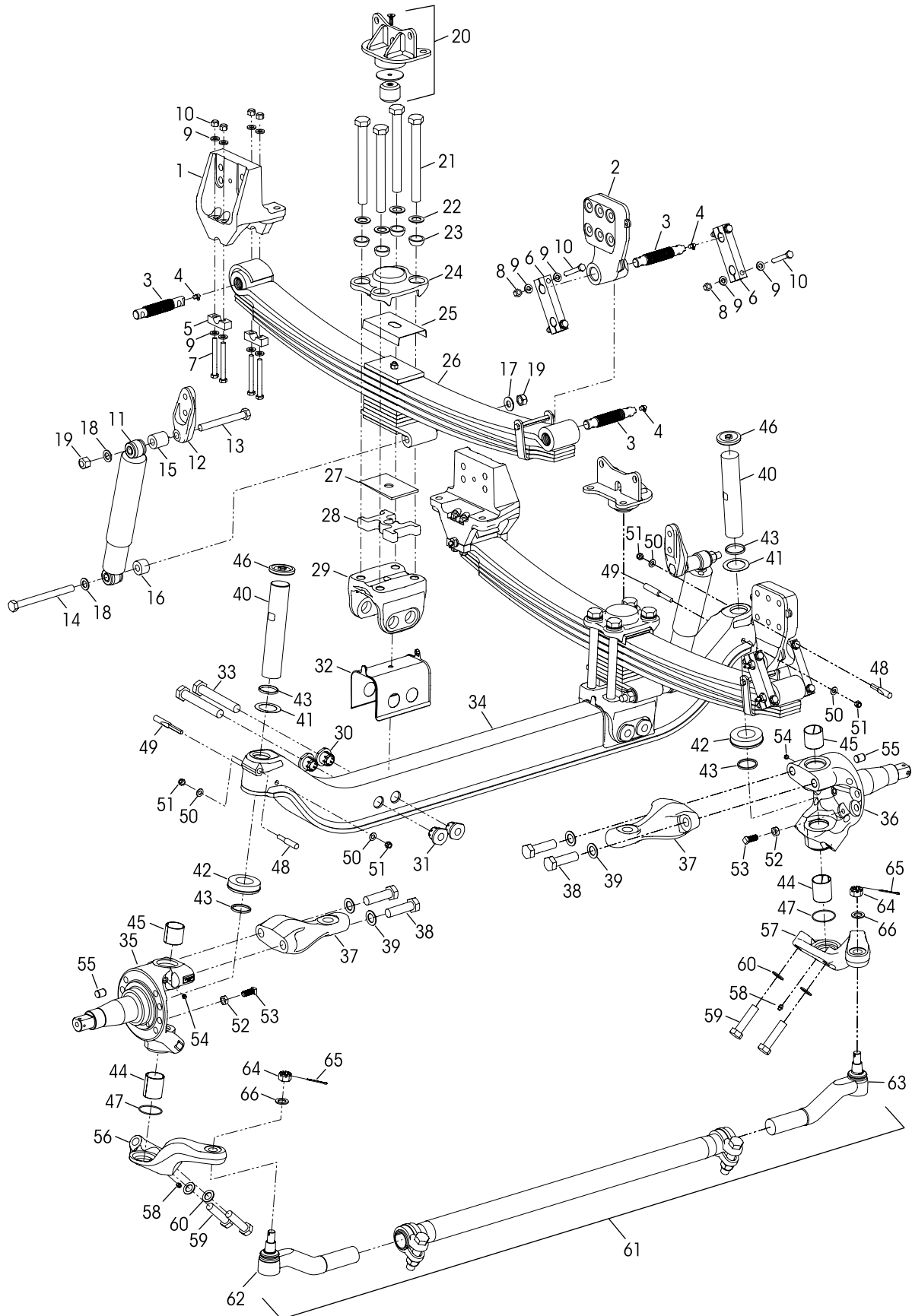



STEERTEK™ NXT High Capacity Steer Axle System for KME Vehicles

KEY NO.	PART NO.	DESCRIPTION	VEHICLE QTY.	KEY NO.	PART NO.	DESCRIPTION	VEHICLE QTY.
1	79894-002	Frame Hanger Assembly	2		80886-XXX	STEERTEK NXT High Capacity Axle Assembly	
2	80159-002	Front	2			Fire and Rescue, Includes Key Nos. 35-36, 40-66, See Table 2 on page 6	
		Frame Hanger Fastener Service Kit, One Side		34	77284-010	Axle	1
	34013-247	Front, Includes Key Nos. 5, 7, 9-10				Knuckle Assembly, Includes Key Nos. 43, 46, 52-55	
	34013-248	Rear, Includes Key Nos. 3-4, 6, 8-10		35	77243-001	Left Hand	1
	34013-249	Single Threaded Pin and Grease Zerk Service Kit, Includes Key Nos. 3-4		36	77243-002	Right Hand	1
3		*Threaded Pin	6	37	77337-008	Steering Arm	2
4		*Grease Zerk	6	38	30550-027	1"-1.4 UNF x 3 1/2" Hex Bolt	4
5	79843-000	Front Hanger Bottom Cap	4	39	22962-051	1" Flat Washer	4
6	79888-001	Rear Shackles	4		34013-230	Kingpin Service Kit, One Side	
7	80362-001	1/2"-20 UNC x 4 1/2" Hex Bolt	8			Includes Key Nos. 40, 41 a, 42-51, 59-60	
8	80362-002	1/2"-20 UNC x 3 1/4" Shackle Hex Bolt	8	40	75923-001	Kingpin	2
9	22962-014	1/2" Flat Washer	32	41		Kingpin Shim (As needed for service)	2
10	17700-034	1/2"-20 UNC Nut	16	a	77241-002	0.01" Thickness	
	34013-311	Single Shock Absorber Service Kit		b	77241-003	0.02"	
		Includes Key Nos. 11, 14-19		42	75918-001	Thrust Bearing	2
11	80606-001	Shock Absorber	2	43	75966-001	Kingpin Seal	4
12	78250-002	Shock Bracket	2			Kingpin Bushing	
13	50764-021	3/4"-10 UNC x 6" Upper Shock Hex Bolt	2	44	75919-001	Lower, 2 1/2" Length	2
14	50764-014	3/4"-10 UNC x 8 1/2" Lower Shock Hex Bolt	2	45	75919-002	Upper, 2" Length	2
		Shock Spacer		46	77209-001	Grease Cap	2
15	59946-014	Upper, 45 mm Thick	2	47	68303-004	O-Ring	2
16	59946-015	Lower Outboard, 28 mm Thick	2			Kingpin Draw Key	
17	59946-005	Lower Inboard, 3 mm Thick	2	48	75925-001	Upper, 3 3/8" Length	2
18	22962-001	3/4" Flat Washer	4	49	75925-002	Lower, 4 3/4" Length	2
19	49842-000	3/4"-10 UNC Nut	4	50	22962-054	7/16" Flat Washer	4
20	91081-000	Jounce Stop Assembly	2	51	17700-008	7/16"-1.4 UNC-2B Nut	4
	80888-XXX	Leaf Spring & Clamp Group Assembly, Includes Key Nos. 21-33, See Table 1 on page 6	2	52	17491-023	5/8"-1.1 UNC-2B Jam Nut	2
	34013-XXX	Clamp Group Service Kit, One Side, Includes Key Nos. 21-23, 25, See Table 1 on page 6		53	80183-000	5/8"-1.1 UNC x 1 1/2" Set Screw	2
21	64107-XXX	1"-8 UNC Hex Bolt, See Table 1 on page 6	8	54	33117-000	Grease Zerk	2
22	22962-051	1" Flat Washer, See Table 1 on page 6	8	55	64246-000	ABS Sensor Sleeve	2
23	78356-002	1" Spherical Washer	8		77244-XXX	Tie Rod Arm Assembly, Includes Key No. 58	
24	78888-000	Top Pad	2			See Table 2 on page 6	
25	79273-001	Spring Liner	2	56		Left Hand	1
26		Leaf Spring Assembly, Includes Key Nos. 3 & 4		57		Right Hand	1
		See Table 1 on page 6		58	33117-000	Grease Zerk	2
27	80143-001	Caster Wedge - 2°	2	59	30418-014	7/8"-1.4 UNF x 3 1/2" Hex Bolt	4
28		Spring Spacer (if equipped)		60	22962-002	7/8" Flat Washer	4
		See Table 1 on page 6		61	79365-001	Tie Rod Assembly, 20K Drop, Includes Key Nos. 62-64	1
29	77232-000	Axle Seat	2			Tie Rod End Service Kits,	
	34013-229	Axle Clamp Collar Service Kit, One Side			60961-884	Axle Set, Includes Kit Nos. 60961-882 and -883	
		Includes Key Nos. 30-33			60961-882	Left Hand, Includes Key Nos. 62, 64-66	
		*Axle Collar			60961-883	Right Hand, Includes Key Nos. 63-66	
		Non Threaded	4			Tie Rod End, Includes Key No. 64	
		Threaded	4	62	79366-001	Left Hand	1
30			4	63	79366-002	Right Hand	1
31			4	64		*7/8"-1.4 UNF-2A Castle Nut	2
32	78887-001	Axle Seat Liner	2	65	17800-004	Cotter Pin	2
33		*1"-8 UNC x 6 1/2" Hex Thru Bolt	4	66	22962-002	7/8" Flat Washer	2

NOTE: * Item included in kit/assembly only, part not sold separately.



Air Disc Brake Assembly

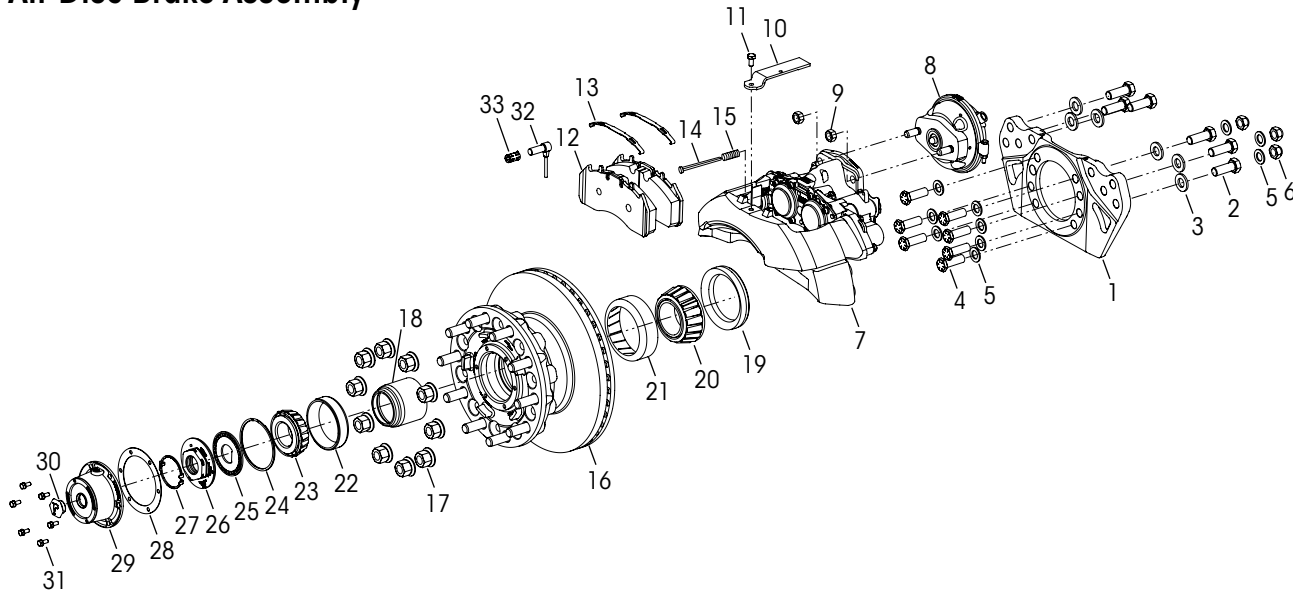

KEY NO.	PART NO.	DESCRIPTION	VEHICLE QTY.
1		*Meritor Torque Plate Assembly Left Hand, Part No. 3215-F-1878 Right Hand, Part No. 3215-E-1877	1
2	69781-002	M20 x 55 mm Hex Head Bolt	12
3	58246-039	M20 Flat Washer	12
4	80345-004	3/4"-16 UNC x 2 1/4" Low Profile Hex Head Bolt	14
5	22962-001	3/4" Flat Washer	20
6	80691-001	3/4"-16 UNC Hex Nut	6
7		*Meritor Air Disc Brake Caliper Assembly, Includes Key Nos. 10-11, 14-15 Left Hand, Part No. EX225H202XX000S Right Hand, Part No. EX225H201XX000S	1
8		*WABCO Air Brake Chamber MGM T24L, Includes K80131-001 Key No. 9 Left Hand, Part No. 423 506 1340 Right Hand, Part No. 423 506 1350	1
9		*Hex Nut *Meritor Disc Pad Retainer Kit No. 22510, Includes Key Nos. 10-11	4
10		*Pad Retainer	
11		*Pad Retainer Bolt *Meritor Air Disc Brake Pad Kit No. 2252H2CG, Includes Key Nos 12-13	
12		*Air Disc Brake Pad	
13		*ADB Pad Spring *Meritor Wear Indicator Kit No. 225255, Includes Key Nos. 14-15	
14		*Wear Indicator	
15		*Wear Indicator Spring	

KEY NO.	PART NO.	DESCRIPTION	VEHICLE QTY.
16		*Conmet Hub and Rotor Assembly Part No. 10083224, Includes Bearings and Seals *Conmet Brake Rotor Replacement Kit No. 10082181, One Wheel End, Includes Rotor and 10 of each Cap Screws and Washers	2
17		**M22 x 1.5 Two-piece Wheel Nut *Conmet Hub Bearing Rebuild Kit No. 10081728, One Wheel End, Includes Key Nos. 18-23 *Conmet Wheel Seal Kit No. 10081519, One Wheel End, Includes Key Nos. 18-19	20
18		*Bearing Spacer Part No. 10034342	
19		*Wheel Seal Part No. 10045883	
20		*Inner Bearing Cone Part No. 10041922	
21		*Inner Bearing Cup Part No. 10041921	
22		*Outer Bearing Cup Part No. 10041923	
23		*Outer Bearing Cone Part No. 10041924 *Conmet Preset Plus FL Nut Assembly Kit No. 10036550, Includes Key Nos. 24-27	
24		*Snap Ring - Double Wind Part No. 10033288	
25		*Spindle Nut Lockwasher Part No. 10031171	
26		*Outer Spindle Nut Part No. 10031170	
27		*Snap Ring Retainer Part No. 10031172	
28		*Federal-Mogul Hub Cap Gasket No. G-3009	2
29		*Federal-Mogul Hub Cap Part No. 343-009, Includes Key No. 30	2
30		*Rubber Plug	
31	64545-002	5/16"-18 UNC x 3/4" Hex Bolt with Retained Washer	12
32		*WABCO ABS Sensor Part No. 441-032-900-0	2
33	64550-000	ABS Sensor Clip	2



Drum Brake Assembly

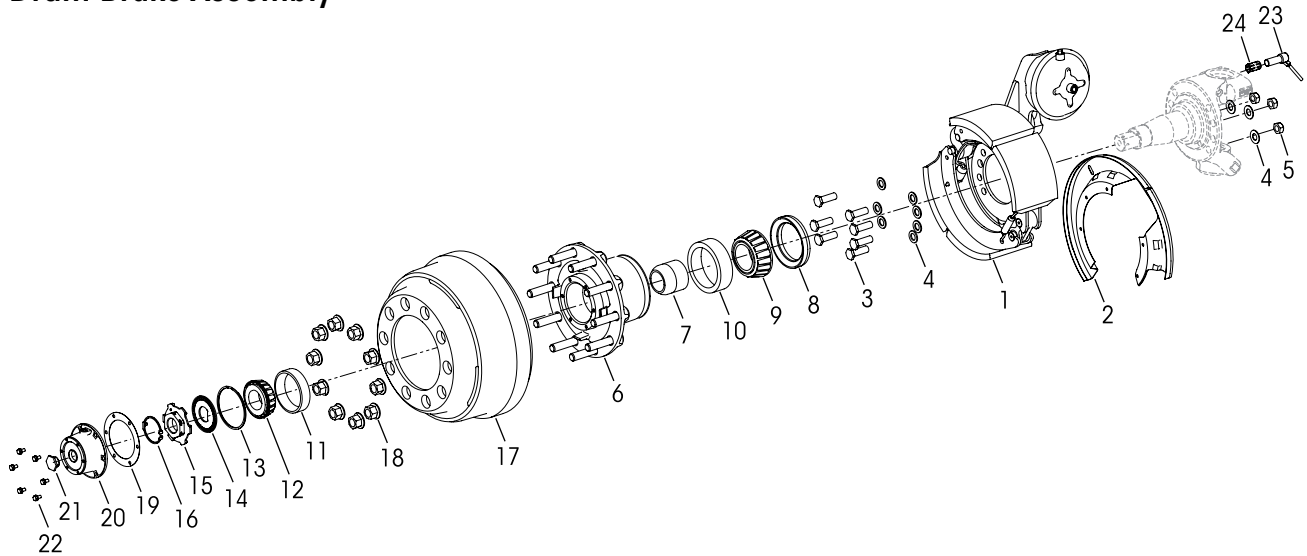

KEY NO.	PART NO.	DESCRIPTION	VEHICLE QTY.	KEY NO.	PART NO.	DESCRIPTION	VEHICLE QTY.
1		*Meritor Drum Brake Foundation Kit, Includes Key No. 2 Left Hand, Part No. QP4-1656-2125 Right Hand, Part No. QP4-1656-2126	1 1	10		*Inner Bearing Cup Part No. 10041921	
2		*Dust Shield	2	11		*Outer Bearing Cup Part No. 10041923	
3	80345-004	3/4"-16 x 2 1/4" Low Profile Hex Head Bolt	14	12		*Outer Bearing Cone Part No. 10041924	
4	22962-001	3/4" Flat Washer	20			*Conmet Preset Plus FL Nut Assembly Kit No. 10036550, Includes Key Nos. 13-16	
5	80691-001	3/4"-16 UNC - 2B Nut	6	13		*Snap Ring - Double Wind Part No. 10033288	
		*Conmet Preset Plus FL Hub Assembly Part No. 10081313, Includes Key Nos. 6-16	2	14		*Spindle Nut Lockwasher Part No. 10031171	
6		*Hub Part No. 10033316		15		*Outer Spindle Nut Part No. 10031170	
		*Conmet Hub Bearing Rebuild Kit No. 10081728, One Wheel End, Includes Key Nos. 7-12		16		*Snap Ring Retainer Part No. 10031172	
		*Conmet Wheel Seal Kit No. 10081519, One Wheel End, Includes Key Nos. 7-8		17		*Conmet Drum 16.5 x 6 Part No. 10033071	
7		*Bearing Spacer Part No. 10034342		18		**M22 x 1.5 Two-piece Wheel Nut	20
8		*Wheel Seal Part No. 10045883		19		*Federal-Mogul Hub Cap Gasket No. G-3009	2
9		*Inner Bearing Cone Part No. 10041922		20		*Federal-Mogul Hub Cap Part No. 343-009, Includes Key No. 21	2
				21		*Rubber Plug	
				22	64545-002	5/16"-18 UNC x 3/4" Hex Bolt with Retained Washer	12
				23		*WABCO ABS Sensor Part No. 441-032-900-0	2
				24	64550-000	ABS Sensor Clip	2

NOTES: * Not supplied by Hendrickson for aftermarket service purposes. Description and part number listed for reference only. For more information and assistance with service, maintenance and rebuild instructions on these components see below component manufacturers:

- Conmet technical and parts support 800.547.9473 and for technical support: www.conmet.com/general/literature, go to Wheel End Literature, scroll down to Service Manual, Lit No. 10084476
- Federal Mogul Technical and Part Support 800.325.8886 or online at www.fme-cat.com
- Meritor Technical and Part Support 888.725.9355, or online for parts: www.meritorpartsexpress.com and for technical support: www.meritorbullpen.com
- WABCO Technical and Part Support 855.228.3203 or online at www.wabco-auto.com/aftermarket-services/inform-product-catalog

** Not supplied by Hendrickson, used for reference only. Contact the vehicle manufacturer for more information.



■ Selection Guides

TABLE 1 Leaf Spring Assembly and Components

Capacity	Ride Height	Leaf Spring & Clamp Group Assembly	Clamp Group Service Kit	Leaf Spring Assembly Key No. 26	1" Hex Bolt Key No. 21		1" Flat Washer (USE ONLY AS SPECIFIED) Key No. 22	Leaf Spring Spacer Key No. 28	
					Length	Part No.		Thickness	Part No.
20K	10"	80888-001	34013-312	82532-000	9"	64107-003	---	---	---
	11"	80888-002	34013-313		10"	64107-008	---	1"	79814-000
22K	10"	80888-101	34013-312	82533-000	9"	64107-003	---	---	---
	11"	80888-102	34013-313		10"	64107-008	---	1"	79814-000
24K	10"	80888-201	34013-314	82534-000	9.5"	64107-007	22962-051	---	---
	11"	80888-202	34013-315		10.5"	64107-009	22962-051	1"	79814-000

⚠ WARNING USE 1" FLAT WASHERS (PART NO. 22962-051) ONLY AS SPECIFIED IN TABLE 1 (LEAF SPRING AND CLAMP GROUP ASSEMBLY). THE TABLE LISTS DIFFERENT CONFIGURATIONS FOR THIS ASSEMBLY. FOR CERTAIN CONFIGURATIONS THE CLAMP GROUP REQUIRES THE USE OF 1" FLAT WASHERS (PART NO. 22962-051) WITH THE SPECIFIED 1" HEX BOLT LENGTH, BUT NOT IN OTHER CONFIGURATION SPECIFICATIONS IN TABLE 1 CAN RESULT IN IMPROPER CLAMP FORCE IN THE LEAF SPRING AND CLAMP GROUP ASSEMBLY, IMPROPER SEATING AND COMPONENT DAMAGE, WHICH CAN CAUSE LOSS OF VEHICLE CONTROL, ADVERSE VEHICLE HANDLING, PROPERTY DAMAGE AND PERSONAL INJURY.

TABLE 2 Axle and Tie Rod Arm Assembly

Wheel Base	STEERTEK NXT	Tie Rod Arm Assembly	
	Axle Assembly Key No. 34	Left Hand Key No. 56	Right Hand Key No. 57
140"-170"	80886-001	77244-057	77244-058
171"-200"	80886-002	77244-059	77244-060
201"-230"	80886-003	77244-061	77244-062
231"-270"	80886-004	77244-063	77244-064

■ Special Tool

KINGPIN BUSHING TOOL – ADJUSTABLE STRAIGHT FLUTE REAMER



The dimension of cutting diameter must facilitate a range of **2.00"-2.01"**

This is a general parts list to provide directional information. Components may vary by model. Questions in regards to parts, contact Hendrickson Truck Parts at 1.866.755.5968 (Toll-free U.S. and Canada), 630.910.2800 (Outside U.S. and Canada) or e-mail: truckparts@hendrickson-intl.com. Actual product performance may vary depending upon vehicle configuration, operation, service and other factors. All applications must comply with applicable Hendrickson specifications and must be approved by the respective vehicle manufacturer with the vehicle in its original, as-built configuration. Contact Hendrickson for additional details regarding specifications, applications, capacities, and operation, service and maintenance instructions.

Call Hendrickson at **1.866.755.5968** (toll-free) or **1.630.910.2800** for additional information.



www.hendrickson-intl.com

TRUCK COMMERCIAL VEHICLE SYSTEMS
 800 South Frontage Road
 Woodridge, IL 60517-4904 USA
 1.866.755.5968 (Toll-free U.S. and Canada)
 1.630.910.2800 (Outside U.S. and Canada)
 Fax 1.630.910.2899

SP-305 Rev A 12-18

© 2018 Hendrickson USA, L.L.C. All Rights Reserved. All trademarks shown are owned by Hendrickson USA, L.L.C., or one of the affiliates, in one or more countries. Information contained in this literature was accurate at the time of publication. Product changes may have been made after the copyright date that are not reflected.

Printed in United States of America