



# **H** TECHNICAL PROCEDURE

## COMFORT AIR® Single Axle Rear Air Suspension for Blue Bird Buses

**SUBJECT:** Service Instructions

**LIT NO:** 17730-246

**DATE:** September 2015      **REVISION:** C

### TABLE OF CONTENTS

<b>Section 1</b>	<b>Introduction</b> . . . . .	2	<b>Section 8</b>	<b>Component Replacement</b> . . . . .	23
<b>Section 2</b>	<b>Product Description</b> . . . . .	2	Fasteners . . . . .	23	
<b>Section 3</b>	<b>Important Safety Notice</b> . . . . .	4	Height Control Valve . . . . .	23	
<b>Section 4</b>	<b>Parts Lists</b> . . . . .	8	Air Spring . . . . .	24	
<b>Section 5</b>	<b>Special Tools</b> . . . . .	10	Shock Absorber . . . . .	26	
<b>Section 6</b>	<b>Preventive Maintenance</b> . . . . .	12	Shock Absorber Lower Mounting Bracket . . . . .	26	
Component Inspection . . . . .	12		Cross Channel . . . . .	28	
QUIK-ALIGN Pivot Bushing Inspection . . . . .	13		Transverse Torque Rods . . . . .	29	
U-bolt Locknuts . . . . .	14		Torque Rod Bushing . . . . .	30	
Transverse Torque Rods . . . . .	15		Clamp Group . . . . .	31	
Air Fitting Inspection . . . . .	16		Main Support Member . . . . .	34	
Shock Absorber . . . . .	16		Frame Hanger . . . . .	38	
<b>Section 7</b>	<b>Alignment &amp; Adjustments</b> . . . . .	18	QUIK-ALIGN Pivot Bushing		
Ride Height Adjustment . . . . .	18		Using a Shop Press . . . . .	40	
Lateral Alignment . . . . .	19		Using Tool No. 66086-203L . . . . .	41	
Pinion Angle . . . . .	20		<b>Section 9</b>	<b>Plumbing Diagram</b> . . . . .	44
Drive Axle Alignment Inspection Procedure . . . . .	21		<b>Section 10</b>	<b>Troubleshooting Guide</b> . . . . .	45
			<b>Section 11</b>	<b>Torque Specifications</b> . . . . .	46

## SECTION 1

# Introduction

This publication is intended to acquaint and assist maintenance personnel in the preventive maintenance, service, repair, and rebuild for the COMFORT AIR® single axle air suspension system as installed on applicable Blue Bird Buses.

### NOTE

Use only Hendrickson Genuine Parts for servicing this suspension system.

It is important to read and understand the entire Technical Procedure publication prior to performing any maintenance, service, repair, or rebuild of this product. The information in this publication contains parts lists, safety information, product specifications, features, proper maintenance, service, repair and rebuild instructions for the COMFORT AIR Suspension.

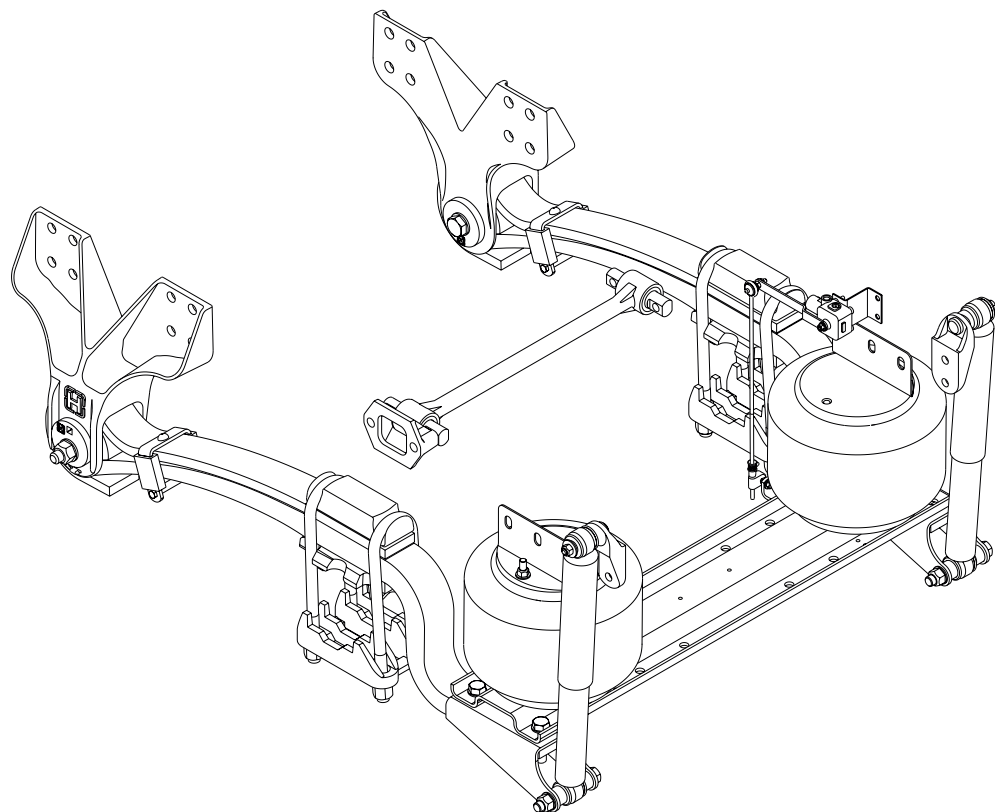
Hendrickson reserves the right to make changes and improvements to its products and publications at any time. Contact Hendrickson Tech Services for information on the latest version of this manual at 1-866-755-5968 (toll-free U.S. and Canada), 1-630-910-2800 (outside U.S. and Canada) or e-mail: techservices@hendrickson-intl.com.

**The latest revision of this publication is also available online at [www.hendrickson-intl.com](http://www.hendrickson-intl.com).**

## SECTION 2

# Product Description

FIGURE 2-1





The **COMFORT AIR rear air suspension system** – based on Hendrickson’s technology, proven in over two million suspensions, helps increase driver comfort and provides superior cargo protection. A Hendrickson air suspension also helps to protect the vehicle from stress. The suspension mounting brackets use common frame hole locations with the mechanical suspension allowing relatively easy conversion to air ride. The system combines superior comfort, outstanding ride, improved handling and reduced maintenance.

- **Air springs** – Adjusts to changing load conditions to deliver superior ride quality.
- **Axle connection** – No welding required for reduced maintenance.
- **Frame hanger** – Wide footprint distributes load over a larger area for reduced frame stress.
- **Height control valve** – Maintains precise ride height control through changing road surfaces, load, and driving conditions.
- **Main support member** – Extended-length generates lower spring rate for optimized roll stiffness, providing a more comfortable and compliant ride.
- **QUIK-ALIGN®** – Fast and easy alignment without shims.
- **Shock absorbers** – Tuned for optimum damping characteristics to provide driving comfort. Protects air springs during rebound.
- **ULTRA ROD® torque rods** – Provides greater durability over conventional torque rods and enhances handling during cornering by controlling lateral forces to maintain axle position.

## COMFORT AIR SPECIFICATIONS

	<b>21K</b>	<b>23K</b>
<b>Suspension Capacity<sup>1</sup>:</b>	21,000 Pound (9,525 kg)	23,000 Pound (10,433 kg)
<b>Suspension Weight<sup>2</sup>:</b>	462 Pound (210 kg)	521 Pound (236 kg)
<b>GVW:</b>	40,000 Pound (18,144 kg)	
<b>Ride Height:</b>	8.0", 8.5", 10.5", 11.5" (with straight frames)	

All applications must comply with applicable Hendrickson specifications and must be approved by Blue Bird with the vehicle in its original, as-built configuration.

All marks are trademarks of their respective owners.

COMFORT AIR is approved for most bus, ambulance and motorhome applications.

1. COMFORT AIR is approved for up to 10 percent off-highway use.
2. The suspension weight includes the frame hanger brackets, main support member assembly, axle clamp group, air springs, shock absorbers, cross channel, upper and lower shock brackets, transverse torque rod and frame bracket, height control system, and fasteners. Weight may vary slightly based upon application specific configuration.

## SECTION 3

# Important Safety Notice

Proper maintenance, service, and repair is important for the reliable operation of the suspension. The procedures recommended by Hendrickson and described in this technical publication are methods of performing such maintenance, service and repair.

All information should be read carefully to help prevent personal injury and to assure that proper methods are used. Improper maintenance, service or repair may damage the vehicle, cause personal injury, render it unsafe in operation, or void manufacturer's warranty.

Failure to follow the safety precautions in this manual can result in personal injury and/or property damage. Carefully read and understand all safety related information within this publication, on all decals and in all such materials provided by the vehicle manufacturer before conducting any maintenance, service or repair.

### ■ EXPLANATION OF SIGNAL WORDS

Hazard "Signal Words" (Danger-Warning-Caution) appear in various locations throughout this publication. Information accented by one of these signal words must be observed to help minimize the risk of personal injury to service personnel, or possibility of improper service methods which may damage the vehicle or render it unsafe.



This is the safety alert symbol. It is used to alert you to potential personal injury hazards. Obey all safety messages that follow this symbol to avoid possible injury or death.

Additional Notes or Service Hints are utilized to emphasize areas of procedural importance and provide suggestions for ease of repair. The following definitions indicate the use of these signal words as they appear throughout the publication.



INDICATES AN IMMINENTLY HAZARDOUS SITUATION WHICH, IF NOT AVOIDED, WILL RESULT IN SERIOUS INJURY OR DEATH.



INDICATES A POTENTIAL HAZARDOUS SITUATION WHICH, IF NOT AVOIDED, COULD RESULT IN SERIOUS INJURY OR DEATH.



INDICATES A POTENTIAL HAZARDOUS SITUATION WHICH, IF NOT AVOIDED, MAY RESULT IN MINOR OR MODERATE INJURY, OR PROPERTY DAMAGE.

#### NOTE

An operating procedure, practice condition, etc. which is essential to emphasize.

#### SERVICE HINT

A helpful suggestion that will make the servicing being performed a little easier and/or faster.

Also note that particular service operations may require the use of special tools designed for specific purposes. These special tools can be found in the Special Tools Section of this publication.



The torque symbol alerts you to tighten fasteners to a specified torque value. Refer to Torque Specifications Section of this publication.



 **WARNING**

## ■ SAFETY PRECAUTIONS

### FASTENERS

DISCARD USED FASTENERS. ALWAYS USE NEW FASTENERS TO COMPLETE A REPAIR. FAILURE TO DO SO COULD RESULT IN FAILURE OF THE PART, OR MATING COMPONENTS, LOSS OF VEHICLE CONTROL, PERSONAL INJURY, OR PROPERTY DAMAGE.

LOOSE OR OVER TORQUED FASTENERS CAN CAUSE COMPONENT DAMAGE, LOSS OF VEHICLE CONTROL, PROPERTY DAMAGE, OR SEVERE PERSONAL INJURY. MAINTAIN CORRECT TORQUE VALUE AT ALL TIMES. CHECK TORQUE VALUES ON A REGULAR BASIS AS SPECIFIED, USING A REGULARLY CALIBRATED TORQUE WRENCH THAT IS REGULARLY CALIBRATED. TORQUE VALUES SPECIFIED IN THIS TECHNICAL PUBLICATION ARE FOR HENDRICKSON SUPPLIED FASTENERS ONLY. IF NON HENDRICKSON FASTENERS ARE USED, FOLLOW TORQUE SPECIFICATION LISTED IN THE VEHICLE MANUFACTURER'S SERVICE MANUAL.

ALL COMFORT AIR FASTENERS FOR BLUE BIRD VEHICLES ARE H-COATED. METRIC BOLTS ARE CLASS 10.9 AND USE CLASS 10.0 LOCKNUTS. NON-METRIC FASTENERS ARE DETAILED AS SPECIFIED ABOVE. DO NOT ASSEMBLE WITHOUT THE PROPER FASTENERS. USE ONLY H-COATED FASTENERS TO SUSTAIN PROPER CLAMP FORCE. FAILURE TO DO SO CAN CAUSE LOSS OF VEHICLE CONTROL, PROPERTY DAMAGE OR PERSONAL INJURY.

 **WARNING**

### LOAD CAPACITY

ADHERE TO THE PUBLISHED CAPACITY RATINGS FOR THE SUSPENSION. ADD-ON AXLE ATTACHMENTS AND OTHER LOAD TRANSFERRING DEVICES, SUCH AS LIFTABLE AXLES, CAN INCREASE THE SUSPENSION LOAD ABOVE ITS RATED AND APPROVED CAPACITIES, WHICH CAN RESULT IN COMPONENT DAMAGE AND LOSS OF VEHICLE CONTROL, POSSIBLY CAUSING PERSONAL INJURY OR PROPERTY DAMAGE.

 **WARNING**

### MODIFYING COMPONENTS

DO NOT MODIFY OR REWORK PARTS WITHOUT AUTHORIZATION FROM HENDRICKSON. DO NOT SUBSTITUTE REPLACEMENT COMPONENTS NOT AUTHORIZED BY HENDRICKSON. USE OF MODIFIED, REWORKED, SUBSTITUTE OR REPLACEMENT PARTS NOT AUTHORIZED BY HENDRICKSON MAY NOT MEET HENDRICKSON'S SPECIFICATIONS, AND CAN RESULT IN FAILURE OF THE PART, LOSS OF VEHICLE CONTROL, POSSIBLE PERSONAL INJURY OR PROPERTY DAMAGE, AND WILL VOID WARRANTY. USE ONLY HENDRICKSON AUTHORIZED REPLACEMENT PARTS.

 **WARNING**

### TORCH/WELDING

DO NOT USE A CUTTING TORCH TO REMOVE ANY FASTENERS. THE USE OF HEAT ON SUSPENSION COMPONENTS WILL ADVERSELY AFFECT THE STRENGTH OF THESE PARTS. A COMPONENT DAMAGED IN THIS MANNER CAN RESULT IN THE LOSS OF VEHICLE CONTROL AND POSSIBLE PERSONAL INJURY OR PROPERTY DAMAGE. EXERCISE EXTREME CARE WHEN HANDLING OR PERFORMING MAINTENANCE IN THE AREA OF THE SUPPORT BEAM. DO NOT CONNECT ARC WELDING GROUND LINE TO THE SUPPORT BEAM. DO NOT STRIKE AN ARC WITH THE ELECTRODE ON THE SUPPORT BEAM. DO NOT USE HEAT NEAR THE SUPPORT BEAM ASSEMBLY. DO NOT NICK OR GOUGE THE SUPPORT BEAM. SUCH IMPROPER ACTIONS CAN DAMAGE THE SUPPORT BEAM ASSEMBLY AND CAUSE LOSS OF VEHICLE CONTROL AND POSSIBLE PERSONAL INJURY OR PROPERTY DAMAGE.

 **CAUTION**

### PROCEDURES AND TOOLS

A TECHNICIAN USING A SERVICE PROCEDURE OR TOOL WHICH HAS NOT BEEN RECOMMENDED BY HENDRICKSON MUST FIRST SATISFY HIMSELF THAT NEITHER HIS SAFETY NOR THE VEHICLE'S SAFETY WILL BE JEOPARDIZED BY THE METHOD OR TOOL SELECTED. INDIVIDUALS DEVIATING IN ANY MANNER FROM THE INSTRUCTIONS PROVIDED WILL ASSUME ALL RISKS OF CONSEQUENTIAL PERSONAL INJURY OR DAMAGE TO EQUIPMENT INVOLVED.

 **WARNING****SHOCK ABSORBERS**

THE SHOCK ABSORBERS ARE THE REBOUND TRAVEL STOPS FOR THE SUSPENSION. ANYTIME THE AXLE ON A COMFORT AIR SUSPENSION IS SUSPENDED IT IS MANDATORY THAT THE SHOCK ABSORBERS REMAIN CONNECTED. FAILURE TO DO SO CAN CAUSE THE AIR SPRINGS TO SEPARATE FROM THE PISTON AND RESULT IN PREMATURE AIR SPRING FAILURE. REPLACEMENT OF SHOCK ABSORBERS WITH NON-HENDRICKSON PARTS CAN ALTER THE REBOUND TRAVEL OF THE SUSPENSION.

 **WARNING****PERSONAL PROTECTIVE EQUIPMENT**

ALWAYS WEAR PROPER EYE PROTECTION AND OTHER REQUIRED PERSONAL PROTECTIVE EQUIPMENT TO HELP PREVENT PERSONAL INJURY WHEN PERFORMING VEHICLE MAINTENANCE, REPAIR OR SERVICE.

 **WARNING****AIR SPRING INFLATION AND DEFLATION**

PRIOR TO DISASSEMBLY OF THE SUSPENSION, AIR SPRING ASSEMBLIES MUST BE DEFLATED. UNRESTRICTED AIR SPRING ASSEMBLIES CAN VIOLENTLY SHIFT. DO NOT INFLATE AIR SPRING ASSEMBLIES WHEN THEY ARE UNRESTRICTED. AIR SPRING ASSEMBLIES MUST BE RESTRICTED BY SUSPENSION OR OTHER ADEQUATE STRUCTURE. DO NOT INFLATE BEYOND PRESSURES RECOMMENDED BY AIR SPRING MANUFACTURER, CONTACT HENDRICKSON TECHNICAL SERVICES FOR DETAILS. IMPROPER USE OR OVER INFLATION MAY CAUSE AIR SPRING ASSEMBLIES TO BURST, CAUSING PROPERTY DAMAGE AND/OR SEVERE PERSONAL INJURY.

DEFLATION: AIR SPRINGS MUST BE DEFLATED PRIOR TO LOOSENING ANY CLAMP GROUP HARDWARE. UNCONSTRAINED AIR SPRINGS WILL VIOLENTLY SHIFT WHICH CAN CAUSE PROPERTY DAMAGE OR SEVERE PERSONAL INJURY.

 **WARNING**

PRIOR TO AND DURING DEFLATION AND INFLATION OF THE AIR SUSPENSION SYSTEM, ENSURE ALL PERSONNEL AND EQUIPMENT ARE CLEAR FROM UNDER THE VEHICLE AND AROUND THE SERVICE AREA, FAILURE TO DO SO CAN CAUSE SERIOUS PERSONAL INJURY, DEATH, OR PROPERTY DAMAGE.

 **CAUTION****AIR SPRING INFLATION**

INFLATE THE SUSPENSION SLOWLY AND MAKE SURE THE RUBBER BLADDER OF THE AIR SPRING INFLATES UNIFORMLY AND IS NOT BINDING. FAILURE TO DO SO CAN CAUSE DAMAGE TO THE AIR SPRING AND/OR MOUNTING BRACKETS AND VOID WARRANTY.

 **CAUTION****AIR SPRING LOWER MOUNTING STUDS**

IF THE AIR SPRING IS BEING REMOVED FOR AN ALTERNATE REPAIR, IT IS MANDATORY TO LUBRICATE THE LOWER AIR SPRING FASTENERS WITH PENETRATING OIL AND REMOVE WITH HAND TOOLS TO PREVENT DAMAGE TO THE LOWER AIR SPRING MOUNTING STUD. FAILURE TO DO SO CAN CAUSE COMPONENT DAMAGE AND VOID WARRANTY.

 **WARNING****PARTS CLEANING**

SOLVENT CLEANERS CAN BE FLAMMABLE, POISONOUS, AND CAUSE BURNS. TO HELP AVOID SERIOUS PERSONAL INJURY, CAREFULLY FOLLOW THE MANUFACTURER'S PRODUCT INSTRUCTIONS AND GUIDELINES AND THE FOLLOWING PROCEDURES:

1. WEAR PROPER EYE PROTECTION.
2. WEAR CLOTHING THAT PROTECTS YOUR SKIN.
3. WORK IN A WELL-VENTILATED AREA.
4. DO NOT USE GASOLINE OR SOLVENTS THAT CONTAIN GASOLINE. GASOLINE CAN EXPLODE.
5. HOT SOLUTION TANKS OR ALKALINE SOLUTIONS MUST BE USED CORRECTLY. FOLLOW THE MANUFACTURER'S RECOMMENDED INSTRUCTIONS AND GUIDELINES CAREFULLY TO HELP PREVENT PERSONAL ACCIDENT OR INJURY.

DO NOT USE HOT SOLUTION TANKS OR WATER AND ALKALINE SOLUTIONS TO CLEAN GROUND OR POLISHED PARTS. DOING SO WILL CAUSE DAMAGE TO THE PARTS AND VOID WARRANTY.



## WARNING

### QUIK-ALIGN FASTENERS

DISCARD USED QUIK-ALIGN FASTENERS. ALWAYS USE NEW QUIK-ALIGN FASTENERS TO COMPLETE A REPAIR. FAILURE TO DO SO COULD RESULT IN FAILURE OF THE PART, OR MATING COMPONENTS, LOSS OF VEHICLE CONTROL, PERSONAL INJURY, OR PROPERTY DAMAGE.

DO NOT ASSEMBLE THE QUIK-ALIGN JOINT WITHOUT THE PROPER FASTENERS. USE ONLY H-COATED FASTENERS TO SUSTAIN PROPER CLAMP FORCE. FAILURE TO DO SO CAN CAUSE LOSS OF VEHICLE CONTROL, PROPERTY DAMAGE OR PERSONAL INJURY AND VOID WARRANTY. ENSURE THAT THE QUIK-ALIGN FASTENER'S TORQUE VALUES ARE SUSTAINED AS RECOMMENDED IN THE TORQUE SPECIFICATIONS SECTION OF THIS PUBLICATION. FAILURE TO DO SO CAN CAUSE LOSS OF VEHICLE CONTROL RESULTING IN PERSONAL INJURY OR PROPERTY DAMAGE.



## WARNING

### TRANSVERSE RODS

THE COMFORT AIR SUSPENSION INCORPORATE TRANSVERSE RODS FOR VEHICLE STABILITY. IF THESE COMPONENTS ARE DISCONNECTED OR ARE NON-FUNCTIONAL THE VEHICLE SHOULD NOT BE OPERATED. FAILURE TO DO SO CAN RESULT IN ADVERSE VEHICLE HANDLING AND POSSIBLE TIRE CONTACT WITH THE FRAME. OPERATING A VEHICLE WITH NON-FUNCTIONAL TRANSVERSE TORQUE RODS CAN RESULT IN LOSS OF VEHICLE CONTROL, SEVERE PERSONAL INJURY, AND PREMATURE COMPONENT DAMAGE.



## WARNING

### U-BOLT FASTENERS

U-BOLTS THAT ARE FOUND TO BE LOOSE REQUIRE THAT MATING COMPONENTS BE INSPECTED FOR SIGNS OF WEAR. ANY WORN COMPONENTS MUST BE REPLACED. FAILURE TO DO SO CAN CAUSE PREMATURE CLAMP GROUP FAILURE, COMPONENT DAMAGE, LOSS OF VEHICLE CONTROL, PROPERTY DAMAGE, OR SEVERE PERSONAL INJURY. MAINTAIN CORRECT TORQUE VALUES AT ALL TIMES. CHECK TORQUE VALUES ON A REGULAR BASIS AS SPECIFIED.



## WARNING

### MAIN SUPPORT MEMBER

FAILURE OF THE MAIN SUPPORT MEMBER BETWEEN THE U-BOLTS WILL REQUIRE THE REPLACEMENT OF THE MAIN SUPPORT MEMBER AND ALL CLAMP GROUP COMPONENTS. FAILURE TO DO SO CAN RESULT IN CLAMP GROUP FAILURE AND FURTHER FAILURE TO THE MAIN SUPPORT MEMBER, WHICH CAN CAUSE LOSS OF VEHICLE CONTROL, PROPERTY DAMAGE OR SEVERE PERSONAL INJURY.



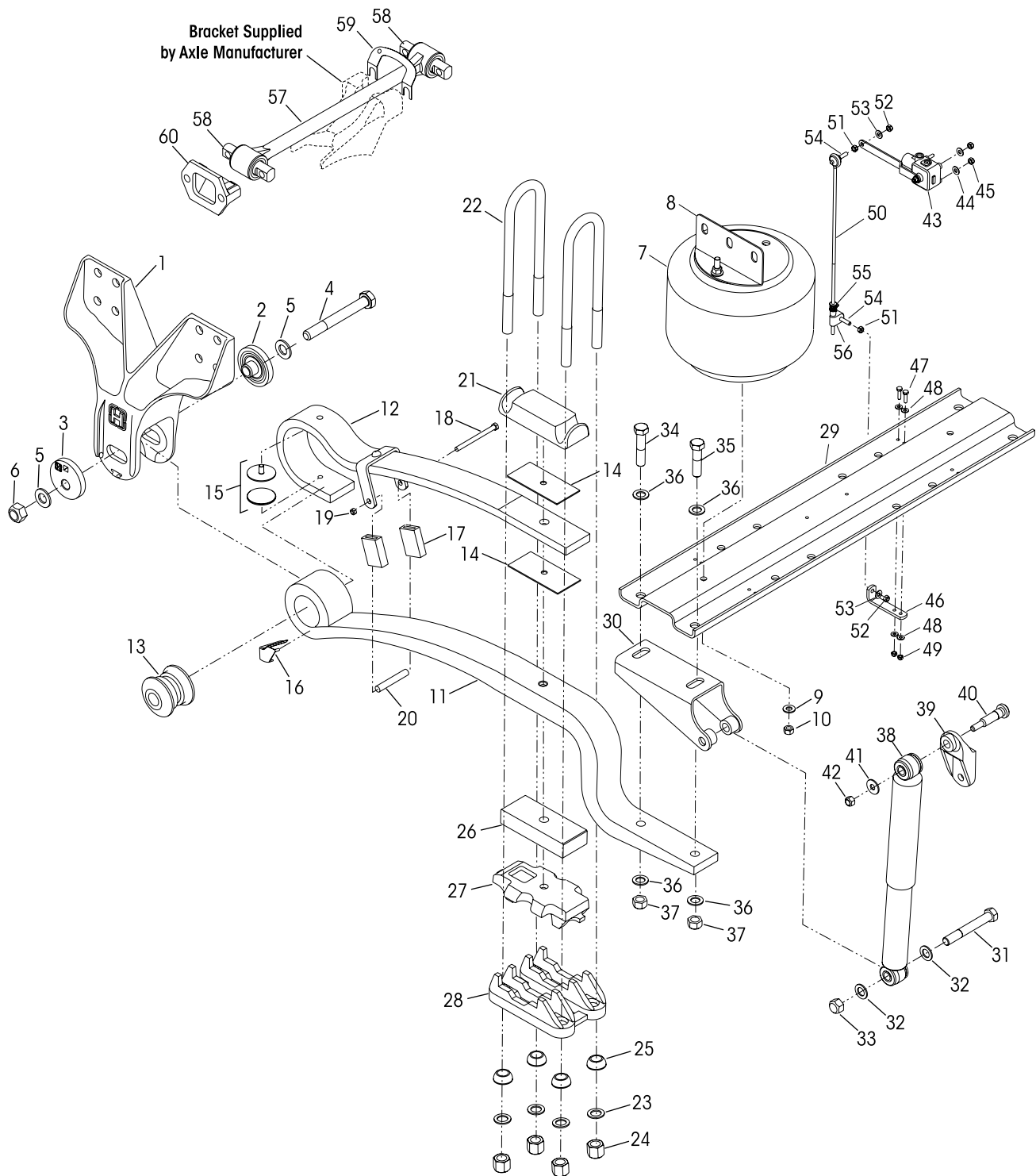
## WARNING

### CROSS CHANNEL

IMPROPER JACKING METHODS CAN CAUSE STRUCTURAL DAMAGE WHICH CAN CAUSE LOSS OF VEHICLE CONTROL, PROPERTY DAMAGE OR SEVERE PERSONAL INJURY AND WILL VOID HENDRICKSON'S WARRANTY.

- DO NOT USE THE SUSPENSION CROSS CHANNEL AS A JACKING POINT
- REFER TO VEHICLE MANUFACTURER FOR PROPER JACKING INSTRUCTIONS

# SECTION 4 Parts Lists







KEY NO.	PART NO.	DESCRIPTION	QTY.	KEY NO.	PART NO.	DESCRIPTION	QTY.
1	60784-000	Frame Hanger	2	28		Axle Bottom Cap	2
	60632-038	<b>QUIK-ALIGN Pivot Bushing Service Kit, Axle Set</b> , Includes Key Nos. 2-6, 13, 15, 61			57024-000	Meritor RS15-120 2-5.0° Pinion Angle LH/RH	
	34013-103	<b>QUIK-ALIGN Pivot Bushing Service Kit, One Side</b> , Includes Key Nos. 4-6, 13, 15, 61			50216-000	Meritor RS21-145, RS23-160 0-9.5° Pinion Angle LH/RH	
	60632-013	<b>QUIK-ALIGN® Collar Service Kit, Axle Set</b> , Includes Key Nos. 2-6 <i>Replaces 60632-001</i>			50216-000	Meritor RC23-160 Negative 0-9.5° Angle LH/RH	
2	64633-000	QUIK-ALIGN Concentric Collar	3	29		Cross Channel, <i>Contact Hendrickson Parts for proper Cross Channel</i>	1
3	64632-000	QUIK-ALIGN Eccentric Collar	1		57356-000	Lower Shock Bracket Assembly, Includes Key Nos. 30-33	2
4	68217-000	1"-8 UNC x 7½" Bolt, <i>Replaces 64107-000</i>	2	30		*Lower Shock Bracket	2
5	68232-000	1" Hardened Washer, <i>Replaces 22962-035</i>	4	31	50764-002	¾"-10 UNC x 5½" Bolt	2
6	68218-000	1"-8 UNC Locknut, <i>Replaces 64108-000</i>	2	32	22962-001	¾" Hardened Washer	4
		Air Spring Assembly, Includes Key Nos. 7-8 and Fasteners	2	33	49842-000	¾"-10 UNC Locknut	2
	60925-002	CA 15K/21K/23K			50763-004	<b>Cross Channel Fastener Service Kit, Axle Set</b> , Includes Key Nos. 34-37	
	60929-002	Front Engine, CA 210/230		34	50764-003	¾"-10 UNC x 3½" Bolt	2
7		*Air Spring	2	35	50764-005	¾"-10 UNC x 3" Bolt	2
8	57096-002	Air Spring Bracket	2	36	22962-001	¾" Hardened Washer	8
	49177-006	<b>Lower Air Spring Fastener Service Kit</b> , Includes Key Nos. 9-10		37	49842-000	¾"-10 UNC Locknut	4
9	22962-014	½" Flat Washer	2	38	60998-003	Shock Absorber, <i>Replaces 60998-001</i>	2
10	17700-010	½"-13 UNC Nylocknut	2		57322-002	Upper Shock Bracket Assembly, Includes Key Nos. 39-42	2
	60779-000	Main Support Assembly, Includes Key Nos. 11-20	2	39		*Upper Shock Bracket	2
11		*Main Support Member	2	40	50368-000	½"-13 UNC Serrated Shank Bolt	2
12		*Secondary Leaf	2	41	22962-031	½" Hardened Washer	2
13	58648-000	QUIK-ALIGN Pivot Bushing	2	42	49846-000	½"-13 UNC Locknut	2
14	37674-051	Liner	4		59013-000	<b>Height Control Valve Service Kit, Axle Set</b> , Includes Key Nos. 43-45	
15	64817-000	Plastic Isolator Puck	4	43		*Height Control Valve	1
16	60392-000	Spring Eye Clip	2	44		*¾" Hardened Washer	2
	49175-026	<b>Spring Clip Fastener Service Kit, Axle Set</b> , Includes Key Nos. 17-19		45		*¼"-20 UNC Locknut	2
17	64272-004	Spring Clip Sleeve, <i>Replaces 64272-000</i>	4			<b>HCV Linkage Lower Bracket Service Kit</b>	
18	37042-006	⅞"-14 UNC Bolt, <i>Replaces 37042-002</i>	2		57430-000	All Except Rear Engine, Includes Key Nos. 46a-50	
19	37587-000	⅞"-14 UNC Nut	2		57430-003	Rear Engine Only, Includes Key Nos. 46b-50	
20		*Clip Bolt Spacer	2	46		HCV Linkage Bracket	1
21		Top Pad	2	a	56789-000	All Except Rear Engine	
	56805-000	21K, 23K lb. Capacity		b	58367-000	Rear Engine	
	57724-000	15K lb. Capacity		47	56935-001	¼"-20 UNC x 1¼" Bolt	2
		<b>U-bolt Service Kit, Axle Set</b>		48	22962-028	¼" Hardened Washer	4
	48718-XXX	⅞" - 21K, 23K lb. Capacity, Specify Length, Includes Key Nos. 22a-24a, 25		49	49983-000	¼"-20 UNC Locknut	2
	48718-104	¾" - 15K lb. capacity, Includes Key Nos. 22b-24b			58994-XXX	Height Control Valve Linkage Assembly, Specify Length, Includes Key Nos. 50-56	1
22		U-bolt	4	50		*HCV Linkage Rod	1
a	47417-XXX	⅞"-14 UNF - 21K, 23K lb. Capacity, Specify Length		51		*⅝"-18 UNC Jam Nut	2
b	49684-014	¾" 26 UNF x 12½" - 15K lb. Capacity		52		*⅝"-18 UNC Locknut	2
23		Hardened Flat Washer	8	53		*⅝" Hardened Washer	2
a	22962-002	⅞" - 21K, 23K lb. Capacity		54		*⅝"-18 UNC Stud	2
b	22962-001	¾" - 15K lb. Capacity		55		*Valve Arm Clamp	1
24		U-bolt Locknut	8	56		*Adjustable Valve Arm Joint	1
a	50765-000	⅞" 14 UNF - 21K, 23K lb. Capacity		57	62000-XXX	Transverse Torque Rod Assembly, Specify Length	1
b	49685-000	¾" 16 UNF - 15K lb. Capacity		58	47691-000	Torque Rod Bushing	2
25	48574-000	Spherical Washer	8	59	49689-000	Torque Rod Shim	As Req.
26	48531-014	Spacer 1½" (As Required)	2	60	22186-000	Transverse Torque Rod Frame Bracket	1
27		Spring Seat	2	61	70867-001	P-80 Lubricant - 10 ml (Not Shown)	As Req.
	57022-010	Meritor RS15-120 4.5° Pinion Angle LH/RH					
	56501-006	Meritor RS21-145, RS23-160 4.5° Pinion Angle LH/RH					
	56501-019	0.0° Pinion Angle LH/RH					
	56501-020	4.5° Pinion Angle LH/RH					
	56501-021	0.0° Pinion Angle LH/RH					
	56501-020	Meritor RC23-160 Negative 4.5° Pinion Angle LH/RH					

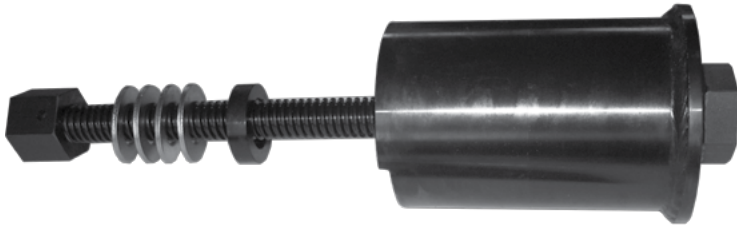
## NOTE

\* Item included in assembly only, part not sold separately.

## SECTION 5 Special Tools

### QUIK-ALIGN TOOLS

#### PIVOT BUSHING TOOL



**Hendrickson Part No. 66086-203L**

Reference Literature No. 59310-061

#### SOCKET TOOL



**Hendrickson Part No. 66086-200**

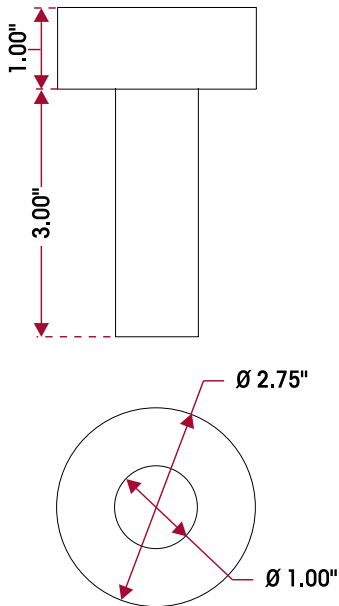
**OTC Part No. 1767**

Visit [otctools.com](http://otctools.com)

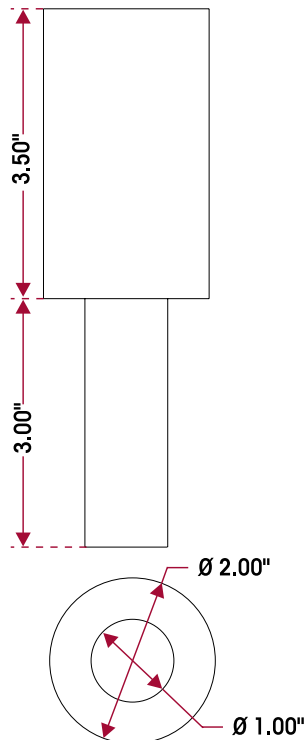
#### PIVOT BUSHING TOOLS

These shop made tools are designed to install and remove pivot bushing. Bushing tools are made from cold rolled steel or equivalent. Drawings are for reference only. Hendrickson does not supply these tools.

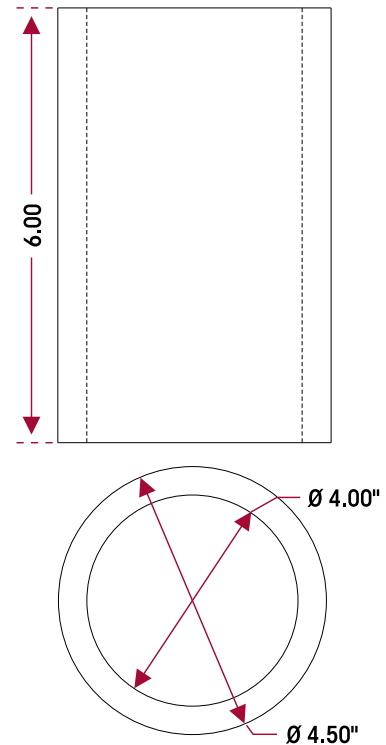
#### INSTALLATION TOOL



#### REMOVAL TOOL



#### RECEIVING TOOL

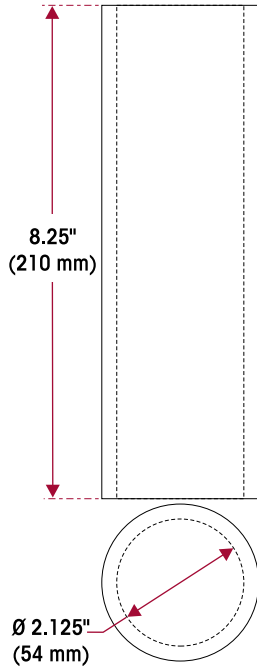




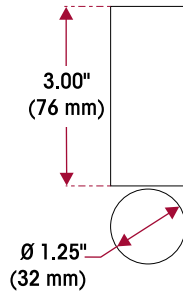
### TORQUE ROD BUSHING TOOLS – ULTRA ROD

These shop made tools are designed for servicing torque rod bushings. Bushing tools are to be made from cold rolled steel or equivalent. The drawings are for reference only, Hendrickson does not supply these tool.

#### RECEIVING TOOL



#### INSTALLATION / REMOVAL TOOL



#### FUNNEL TOOL

Hendrickson Part No. 66086-001  
ULTRA ROD





## SECTION 6

# Preventive Maintenance

Following appropriate inspection procedures is important to help ensure the proper maintenance and operation of the COMFORT AIR suspension system and component parts function to their highest efficiency. Look for bent or cracked parts. Replace all worn or damaged parts.

### HENDRICKSON RECOMMENDED PREVENTIVE MAINTENANCE INTERVALS

- Preparation for delivery
- The first 1,000 miles (1,600 kilometers)
- On-highway – every 20,000 miles (32,000 kilometers) or every 6 months, whichever comes first

### COMPONENT INSPECTION

- **Air spring** – Look for chafing or any signs of spring or component damage. Ensure that the upper bead plate is tight against the underside of the frame. Check for any lateral slippage at the lower air spring bracket. Replace all worn or damaged parts.
- **Clamp group** – Visually inspect for any loose or damaged fasteners. Verify the U-bolt locknuts have the proper torque values maintained. See the U-bolt Locknuts in this section.
- **Cross channel** – Check for cracks, damage, metal shavings, or looseness at the main support member connection. Replace all worn or damaged parts.
- **Fasteners** – Look for any loose or damaged fasteners on the entire suspension. Make sure all fasteners are tightened to a torque value within the specified torque range. See Torque Specifications Section of this publication for recommended torque requirements. Use a calibrated torque wrench to check torque in a tightening direction. As soon as the fastener starts to move, record the torque. Correct the torque if necessary. Replace any worn or damaged fasteners with genuine specified fasteners.
- **Frame hanger bracket** – Check for any signs of loosening or damage at the QUIK-ALIGN connections. Check for cracks, damage, or any signs of looseness at the mounting fasteners. Replace all worn or damaged parts.
- **Height control valve and air lines** – Check the suspension air system for air leaks. Check all air lines for proper routing. Check for chafing or pinched air lines. Check the height control valve linkage for damage or interference with peripheral components. Replace all worn or damaged parts.
- **Main support member assembly** – Look for signs of looseness, cracks, or other damage. Inspect QUIK-ALIGN bushings for looseness, torn or shredded rubber. Inspect the cross channel connection for looseness or damage. Inspect isolator puck for wear or damage. Inspect secondary leaf for signs of looseness or damage. Check torque on QUIK-ALIGN fasteners, cross channel fasteners, and U-bolts. Correct the torque if necessary. Replace all worn or damaged parts.
- **QUIK-ALIGN connection** — Visually inspect the connection for signs of looseness or movement. Visually inspect the bushing for wear. Verify the connections have the proper torque values maintained. See the Torque Specification Section of this publication for recommended torque requirements.  
See QUIK-ALIGN Fasteners Warnings in the Important Safety Notice Section of this publication prior to installing QUIK-ALIGN connection.
- **Shock absorbers** – Look for any signs of dents or leakage. Misting is not considered a leak, see Shock Absorber Inspection in this section.



- **Tire wear** – Inspect the tires for wear patterns that may indicate suspension damage or misalignment. Replace all worn or damaged parts.
- **Torque rods** – All torque rods must be inspected for looseness, torn or shredded rubber, and for proper torque. If there is metal-to-metal contact in the bushing joint, this is a sign of excessive bushing wear and the bushing needs to be replaced. Replace all worn or damaged parts.
- **Wear and damage** – Inspect all parts of the suspension for wear and damage. Look for bent or cracked parts. Replace all worn or damaged parts.

See vehicle manufacturer's applicable publications for other preventive maintenance requirements.

## QUIK-ALIGN PIVOT BUSHING INSPECTION

### WARNING

THE PIVOT BUSHINGS ARE CRITICAL COMPONENTS OF THE COMFORT AIR SUSPENSIONS. IF THESE COMPONENTS APPEAR DAMAGED OR WORN THE COMPONENT MUST BE REPLACED. FAILURE TO REPLACE SUCH WORN OR DAMAGED COMPONENTS CAN RESULT IN THE DEFORMATION OF PARTS, LOSS OF CLAMP FORCE, BOLT FAILURE, LOSS OF THE AXLE'S ALIGNMENT, LOSS OF VEHICLE CONTROL, PROPERTY DAMAGE, OR PERSONAL INJURY.

There are two types of pivot bushing inspections. The pivot bushing can be visually inspected by looking at the outer rubber flange(s) of the bushing. If the visual inspection warrants, a physical inspection can be conducted in which disassembly is required.

### PIVOT BUSHING VISUAL INSPECTION

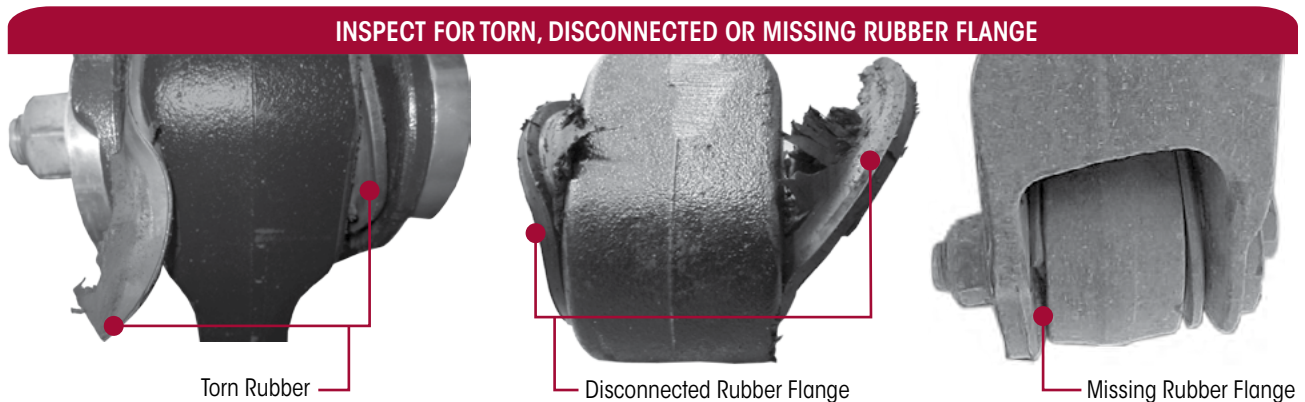
To perform pivot bushing visual inspection, it is not necessary to disassemble the pivot bushing connection. If the pivot bushing rubber flange(s) are intact and there are no signs of metal to metal contact the bushing does not require replacement.

- The main support member is designed with the pivot bushing centered in the end hub. If the pivot bushing is not centered in the end hub, it is an indication that the pivot bushing could be worn and a pivot bushing physical inspection is required.
- If the pivot bushing shows signs of torn, separated or disconnected rubber, see Figures 6-1 and 6-2, this could be a result of axle misalignment. If this condition is evident, a pivot bushing physical inspection is required.
- If the outer rubber flange(s) is missing, or there are shards of rubber visible, see Figure 6-3, this could be a result of axle misalignment. If this condition is evident, pivot bushing replacement is required.

FIGURE 6-1

FIGURE 6-2

FIGURE 6-3



### PIVOT BUSHING PHYSICAL INSPECTION

1. Remove the main support assembly, refer to Main Support Member in the Component Replacement of this publication.
2. After removal, inspect the pivot bushing connection, examine the pivot bushing inner metal area.
3. No replacement is needed if the bushing exhibits a tight joint, see Figure 6-4. An imprinted two-line wear pattern on the bushing inner metal indicates the pivot bushing is securely clamped in the frame hanger.
4. Inspect pivot bushing, replacement is necessary if any indications of the following are apparent, see Figure 6-5:
  - Signs of rust, distorted, separated or torn rubber, elongated or damaged bore. This could be a result of axle misalignment or loose fasteners.
5. Inspect the inside of the frame hanger legs and the QUIK-ALIGN collars. If any of the following are present, the pivot bushing and one or more of the mating components may require replacement:
  - Evidence of wear marks on the inside of the frame hanger legs indicating metal to metal contact or movement.
  - The snout of the QUIK-ALIGN concentric or eccentric collar is elongated or damaged.
6. Check the suspension alignment and adjust if necessary. Refer to Alignment & Adjustments Section of this publication.

FIGURE 6-4

#### GOOD JOINT - NO REPLACEMENT NEEDED

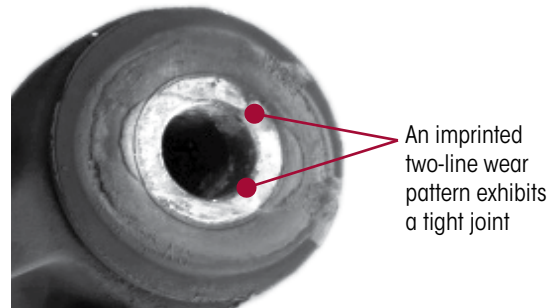
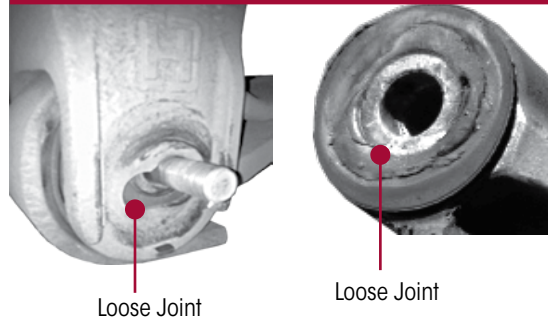


FIGURE 6-5

#### INSPECT FOR INDICATIONS OF A LOOSE JOINT



### U-BOLT LOCKNUTS

#### NOTE

Hendrickson Truck Suspension Systems U-bolt clamp group hardware for the COMFORT AIR suspension are phosphate and oil coated  $\frac{3}{4}$ "-16 UNF /  $\frac{7}{8}$ "-14 UNF Grade C high locknuts and  $\frac{3}{4}$ "-16 UNF /  $\frac{7}{8}$ "-14 UNF Grade 8 U-bolts.

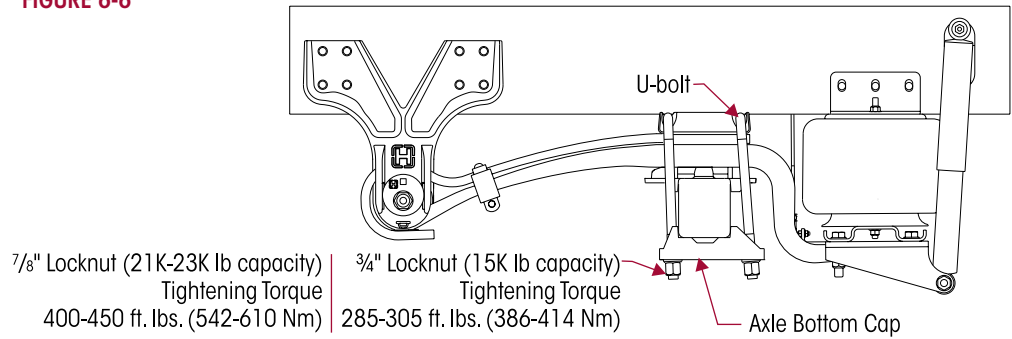
#### WARNING

IT IS IMPORTANT THAT THE U-BOLT CLAMP GROUP CONNECTION BE PROPERLY ALIGNED AND HAVE THE PROPER TIGHTENING TORQUE VALUES MAINTAINED. METAL SURFACES CAN WORK AND WEAR AGAINST OTHER RELATED CLAMP GROUP COMPONENTS IF NOT PROPERLY ALIGNED OR PROPERLY TIGHTENED TO MAINTAIN THE PROPER CLAMP FORCE. FAILURE TO DO SO CAN CAUSE PREMATURE COMPONENT WEAR, POSSIBLE SEPARATION OF THE CLAMP GROUP, CAUSING LOSS OF VEHICLE CONTROL, PROPERTY DAMAGE, OR PERSONAL INJURY.

Maintaining the correct U-bolt torque value is important to help ensure proper suspension component performance.

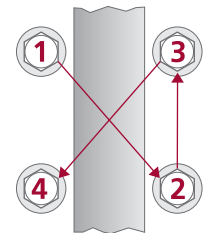


**FIGURE 6-6**



1. Inspect the U-bolts for proper seating of components, i.e. no gaps, etc.
2. U-bolt locknuts must be torqued to specification, refer to Torque Specification Section of this publication. **DO NOT** exceed specified torque on U-bolt locknuts.
3. U-bolt locknuts must be re-torqued at the following intervals:
  - At preparation for delivery.
  - At 1,000 miles (1,600 km) of service on a new vehicle or vehicle with serviced axle attachment assembly.
  - Thereafter follow the 1-year / 20,000 miles (32,000 km) inspection and re-torque interval.
4. Tighten the U-bolt locknuts in the proper sequence, shown in Figure 6-7, evenly in 50 foot pounds increments to achieve uniform bolt tension to:
  - 7/8" Locknuts (21K-23K pound capacity) to 400-450 foot pounds (542-610 Nm) torque
  - 3/4" Locknuts (15K pound capacity) to 285-305 foot pounds (386-414 Nm) torque

**FIGURE 6-7**



## TRANSVERSE TORQUE RODS



### WARNING

THE COMFORT AIR SUSPENSION INCORPORATE TRANSVERSE RODS FOR VEHICLE STABILITY. IF THESE COMPONENTS ARE DISCONNECTED OR ARE NON-FUNCTIONAL THE VEHICLE SHOULD NOT BE OPERATED. FAILURE TO DO SO CAN RESULT IN ADVERSE VEHICLE HANDLING AND POSSIBLE TIRE CONTACT WITH THE FRAME. OPERATING A VEHICLE WITH NON-FUNCTIONAL TRANSVERSE TORQUE RODS CAN RESULT IN LOSS OF VEHICLE CONTROL, SEVERE PERSONAL INJURY, AND PREMATURE COMPONENT DAMAGE.

### NOTE

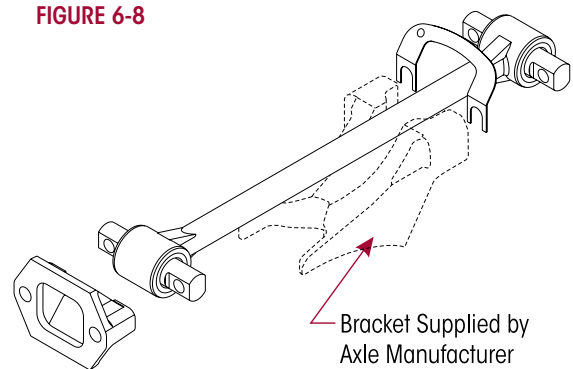
Hendrickson recommends the use of H-Coated, Class 10.9 bolts and Class 10 locknuts for all straddle mount torque rod attachments.

**FIGURE 6-8**

**Visually inspect torque rod bushings** for torn or shredded rubber, inspect for bent, cracked, or broken torque rods, and for end hubs with an elongated "oval" shape. Any of these conditions will require component replacement.

**Torque rod looseness** inspection is necessary. With the vehicle shut down, a lever check can be made with a long pry bar placed under each rod end and pressure applied.

**Torque rod length** is determined by the vehicle manufacturer to center the axles under the frame.





- If the lateral alignment of the axles is incorrect, it may be necessary to shim the transverse torque rod at the straddle mount end, see Figure 6-8. Refer to Lateral Alignment in the Alignment & Adjustments Section of this publication.
- The transverse torque rods also control axle walk-out during cornering. The mounting brackets at the axle housing end of the torque rods are furnished and welded into position on the axle housings by the axle or vehicle manufacturer, see Figure 6-8.

The torque rod may be renewed by pressing out the worn bushings and installing new replacement bushings, see torque rod removal and bushing replacement in Component Replacement Section of this publication. A two-piece rod is also available to cut and weld to the desired length, see Hendrickson Literature No. 45745-148.

## AIR FITTING INSPECTION

1. If an air leak is suspected, begin by building up the air system to normal operating pressure.
2. Spray all nylon tube air fittings with a soapy water solution to detect the leak location.

### NOTE

Air lines and fittings may be inspected for leaks using a soapy water solution. The height control valve, however, cannot be inspected using this method. All height control valves have an allowable leakage rate.

3. If an air leak is located, ensure the tubing end is clean and in good condition and the end is cut square. Check to see if the tubing is binding, bent or being pulled upon.
4. Visually inspect the air fitting's O-ring seal for signs of damage or contamination.

## SHOCK ABSORBER

Hendrickson uses a long service life, premium shock absorber on all COMFORT AIR suspensions. If shock absorber replacement is necessary, Hendrickson recommends that the shock absorbers be replaced with original Hendrickson Genuine parts for servicing. Failure to do so will affect the suspension performance, durability, and will void the warranty.

Inspection of the shock absorber can be performed by doing a heat test, and a visual inspection, also inspect the shock absorber mounting brackets and hardware for damage or wear, replace as necessary. See instructions on shock absorber replacement in the Component Replacement Section of this publication. It is not necessary to replace shock absorbers in pairs if one shock absorber requires replacement.

### HEAT TEST

1. Drive the vehicle at moderate speeds on rough road for minimum of fifteen minutes.

**DO NOT GRAB THE SHOCK AS IT COULD POSSIBLY CAUSE PERSONAL INJURY.**

2. Use an infrared thermometer to check the temperature of the shock absorber. This can also be performed by carefully touching the shock body below the dust cover. Touch the frame to get an ambient reference, see Figure 6-9. A warm shock absorber is acceptable, a cold shock absorber should be replaced.
3. To inspect for an internal failure, remove and shake the suspected shock. Listen for the sound of metal parts rattling inside. Rattling of metal parts can indicate that the shock has an internal failure.

If the shock is damaged install new shock absorber as detailed in the Component Replacement Section of this publication.

**FIGURE 6-9**



### WARNING



## VISUAL INSPECTION

Look for these potential problems when doing a visual inspection, see Figure 6-10. Inspect the shock absorbers fully extended. Replace as necessary.

**FIGURE 6-10**



## LEAKING VS. MISTING SHOCK VISUAL INSPECTION

The inspection must not be conducted after driving in wet weather or a vehicle wash. Shocks need to be free from water. Many shocks are often misdiagnosed as failures. Misting is the process whereby very small amounts of shock fluid evaporate at a high operating temperature through the upper seal of the shock. When the "mist" reaches the cooler outside air, it condenses and forms a film on the outside of the shock body. Misting is perfectly normal and necessary function of the shock. The fluid which evaporates through the seal area helps to lubricate and prolong the life of the seal.

A shock that is leaking and needs to be replaced will show signs of fluid leaking in streams from the upper seal. These streams can easily be seen when the shock is fully extended, underneath the main body (dust cover) of the shock, see Figure 6-11. Look for these potential problems when doing a visual inspection. Inspect the shock absorbers fully extended. Replace as necessary.

### NOTE

The COMFORT AIR suspension is equipped with a premium seal on the shock, however this seal will allow for misting to appear on the shock body (misting is not a leak and is considered acceptable).

**FIGURE 6-11**



## SECTION 7

## Alignment &amp; Adjustments

## RIDE HEIGHT ADJUSTMENT

The Comfort Air suspension for Blue Bird vehicles is equipped with a height control valve located above the left air spring on the inside of the left frame rail. Refer to the Plumbing Diagram Section of this publication.

1. Use a work bay with a level surface.
  2. Relax the suspension by slowly moving the vehicle back and forth several times in a straight line without using the brakes. This will slacken or loosen the suspension as the vehicle is positioned. End with all wheels positioned straight ahead.
  3. **DO NOT** set the parking brake. Chock the front wheels of the vehicle.
  4. Verify the air system is at full operating pressure.
  5. See Air Spring Warnings and Instructions in the Important Safety Notice Section of this publication prior to deflating or inflating the air system.
  6. Cycle the air system. Disconnect the height control valve arm from the rubber grommet. Lower the height control valve arm to exhaust the air in the air springs and deflate the suspension. Reconnect the height control valve arm to the rubber grommet to inflate the suspension.
- **Method A** – The **actual ride height** is measured at the bottom of the frame rail to the bottom of the main support member assembly as shown in Figure 7-1. The actual ride height is  $4\frac{7}{8}'' \pm \frac{1}{4}''$  as shown in the Table 1, **Dimension A**.
  - **Method B** – The **referenced ride height** is measured at the normal running length of the shock absorber. Measure from center of upper shock eye to center of lower shock eye, see **Dimension B** in Figure 7-1. The specific running length of the shock absorber varies per specific OEM applications as shown in the matrix.

FIGURE 7-1

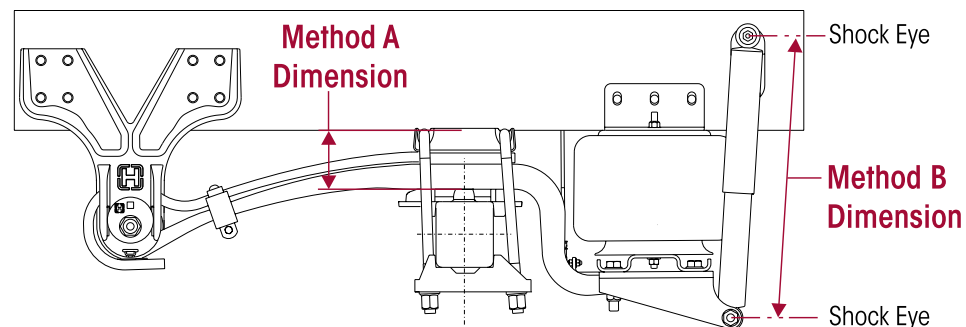


TABLE 1

OEM AND MODEL	METHOD A	METHOD B
	ACTUAL RIDE HEIGHT Bottom of the Frame Rail to the Bottom of the Main Support Member	REFERENCED RIDE HEIGHT Shock Absorber Length with a Tolerance of $\frac{1}{4}''$
BLUE BIRD - A3FE/A3RE/BBCV	$4\frac{7}{8}'' \pm \frac{1}{4}''$ (124 mm $\pm$ 6 mm)	$22.68'' \pm \frac{1}{4}''$ (576 mm $\pm$ 6 mm)
BLUE BIRD - RE/QBRE		$22.75'' \pm \frac{1}{4}''$ (578 mm $\pm$ 6 mm)
BLUE BIRD - TCFE/CSFE		
BLUE BIRD - TCFE FLAT FLOOR		
BLUE BIRD - C4RE		
BLUE BIRD - TSFE/CIFE		$23.00'' \pm \frac{1}{4}''$ (584 mm $\pm$ 6 mm)

**WARNING**

7. If an adjustment is required, verify that the air system is at full operating pressure.

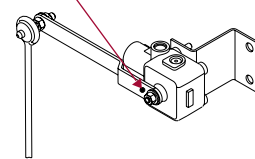
PRIOR TO AND DURING DEFLATION AND INFLATION OF THE AIR SUSPENSION SYSTEM, ENSURE THAT ALL PERSONNEL AND EQUIPMENT ARE CLEAR FROM UNDER THE VEHICLE AND AROUND THE SERVICE AREA, FAILURE TO DO SO CAN CAUSE SERIOUS PERSONAL INJURY, DEATH, OR PROPERTY DAMAGE.

8. See additional Air Spring Cautions and Warnings in the Important Safety Notice Section of this publication prior to deflating or inflating the air system.
9. Disconnect the height control valve arm from the rubber grommet. Lower the height control valve arm to exhaust the air from the air springs and deflate the rear suspension.
10. Refill the suspension by raising the height control valve arm by hand, so that the suspension is above the proper ride height.
11. Lower the height control valve arm to exhaust the air system until the suspension is at proper ride height.

12. Use a 1/8" wooden dowel rod (golf tee) to set the neutral position for the height control valve by aligning the hole in the height control valve arm with the hole in the height control valve cover, as shown in Figure 7-2. **DO NOT** use a metal rod or nail as this may cause damage to the height control valve.

**FIGURE 7-2**

To set neutral position align hole with hole on height control valve cover



13. Adjust the extension rod assembly so the rubber grommet can be reconnected to the height control valve arm at the proper height. Check the rubber components for any tearing or damage, replace as necessary.
14. Reconnect the height control valve arm to the rubber grommet.
15. Tighten the clamp on the adjustable valve arm joint with a screwdriver until securely fastened.
16. Remove the dowel from the height control valve.
17. If equipped with a suspension dump system in the cab, cycle the suspension air system by using the cab dump valve control. If not equipped with a dump valve, cycle the height control valve arm as stated in Steps numbers 4 through 6 above.
18. Recheck the ride height.
19. Repeat Steps 3 through 18 until the ride height is within specification.

**SERVICE HINT**

It is very important that the leveling valve be cycled completely before and after any ride height adjustments. The cycling of the leveling valve will help make the adjustment more accurate. Be sure to maintain full system air pressure while setting or inspecting ride height.

**NOTE**

During cycle operation of the height control valve it is normal to experience a limited amount of exhaust noise.

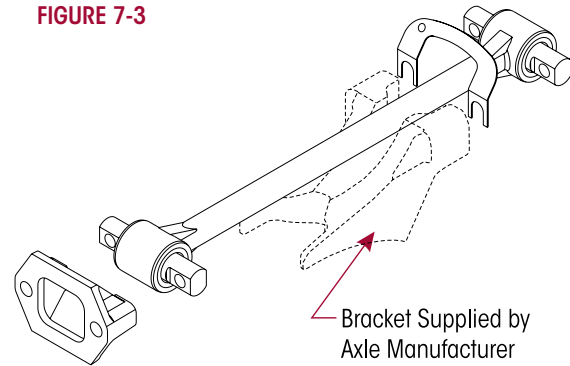
**LATERAL ALIGNMENT**

1. Use a work bay with a level surface.
2. Relax the suspension by slowly moving the vehicle back and forth several times in a straight line without using the brakes. This will slacken or loosen the suspension as the vehicle is positioned. End with all wheels positioned straight ahead.
3. **DO NOT** set the parking brake. Chock the front wheels of the vehicle.
4. Verify and maintain the air system at full operating pressure.
5. Verify the vehicle is at the correct ride height. Correct as necessary. Refer to Ride Height Adjustment in this section.
6. Verify all suspension components are in good condition. Repair or replace any worn or damaged suspension components before proceeding with the alignment process.

7. Ensure all drive axle tires are the same size and properly inflated.
8. Measure from the outside of the frame rail to the rim flange of the inner tire. Record the measurement.
9. Measure the same distance on the opposite side of the same axle. Record the measurement.
10. Subtract the two measurements to get a difference between the two. If the difference is greater than  $\frac{1}{8}$ " (3 mm), it will be necessary to correct the lateral alignment. Adding or removing shims as shown in Figure 7-3 accomplishes this.

FIGURE 7-3

- A general rule of thumb is to use a shim with a thickness that is half of the difference between the two measurements.
- Shims can be installed either between the transverse torque rod and the transverse torque rod frame bracket or between the transverse torque rod and axle tower bracket.

**EXAMPLE**

If the lateral alignment is out of specification by  $\frac{1}{4}$ " (6 mm), remove or install a  $\frac{1}{8}$ " (3 mm) shim between the transverse torque rod and frame rail as needed, see Figure 7-3. Refer to Longitudinal and Transverse Torque Rod Section in Preventive Maintenance Section of this publication.

It is important to check the transverse torque rod fasteners for proper torque during preventive maintenance service intervals. Refer to Torque Specifications Section of this publication.

**PINION ANGLE**

The vehicle manufacturer establishes drive axle pinion angles. If it is necessary to fine-tune the pinion angle it will be necessary to contact the vehicle manufacturer.

**TO CHECK THE PINION ANGLE**

1. Use a work bay with a level floor. Drive the vehicle slowly, straight ahead. Try to slacken or loosen the suspension as the vehicle is positioned. End with all wheels positioned straight ahead.
2. Verify vehicle is at the proper ride height, see Ride Height Adjustment in this section.
3. Install a digital protractor on the drive axle housing as shown in Figure 7-4.
4. Verify the pinion angle is correct per the vehicle manufacturer's specifications. If an adjustment is needed please contact the vehicle manufacturer.

FIGURE 7-4



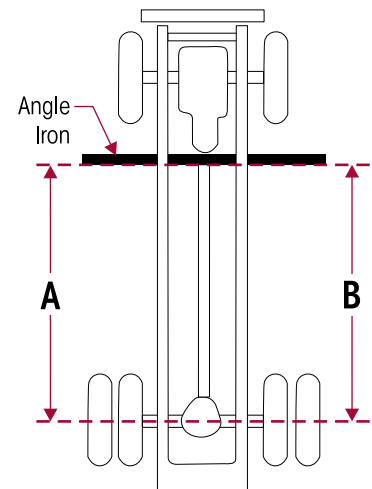
## DRIVE AXLE ALIGNMENT INSPECTION PROCEDURE

Proper alignment is essential for maximum ride quality, performance, and tire service life, the recommended alignment procedure is described below. This procedure should be performed if excessive or irregular tire wear is observed, or any time the main support member assembly and QUIK-ALIGN connection is removed for service.

**NOTE** It is important to have the QUIK-ALIGN locknut pre-torqued to 100 foot pounds (135 Nm) on the left side of vehicle only. All other suspension fasteners must be tightened to their specified torque values. The total range of rear axle alignment adjustment is 1.0" (25.4 mm).

**NOTE** Use a new QUIK-ALIGN kit for any axle alignment or disassembly of the QUIK-ALIGN connection. This ensures proper clamping force is applied to the connection.

**FIGURE 7-5**



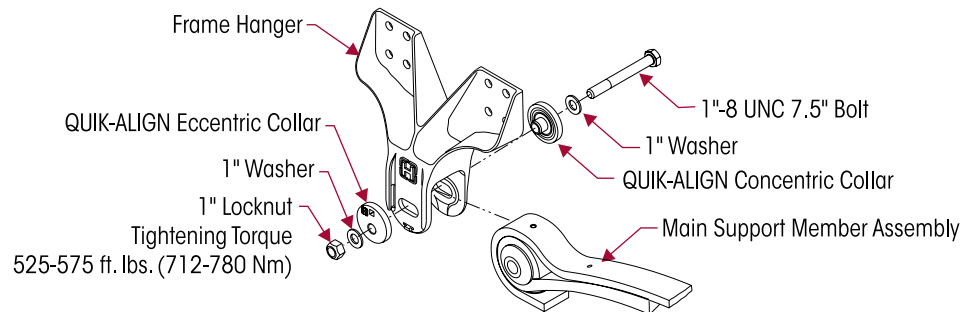
1. Use a work bay with a level surface.
2. Relax the suspension by slowly moving the vehicle back and forth several times in a straight line without using the brakes. This will slacken or loosen the suspension as the vehicle is positioned. End with all wheels positioned straight ahead.
3. **DO NOT** set the parking brake. Chock the front wheels of the vehicle.
4. Verify and maintain the air system at full operating pressure.
5. Verify the vehicle is at the correct ride height. Correct as necessary. Refer to Ride Height Adjustment in this section.
6. Verify all suspension components are in good condition. Repair or replace any worn or damaged suspension components before proceeding with the alignment process.
7. Ensure all drive axle tires are the same size.
8. If axle alignment equipment is not available, using "C" clamps, securely clamp a six-foot piece of STRAIGHT bar stock or angle iron across the lower frame flange as shown in Figure 7-5. Select a location for the angle iron as far forward of the drive axle as possible where components will not interfere.
9. Accurately square the straight edge to the frame using a carpenter's square.
10. Using a measuring tape, measure from the straight edge to the forward face of the front drive axle arms at the centerline on both sides of the vehicle as shown in Figure 7-5, **A** and **B**.
11. Calculate the difference between measurements **A** and **B**.
  - a. If the front drive axle is within vehicle manufacturer's specifications then the alignment of drive axle is acceptable.
  - b. If alignment of the front drive axle **IS NOT** within the vehicle manufacturer's specifications, then the alignment of this axle **MUST** be corrected. Proceed to Steps 12 to 16.
12. Remove the existing left side QUIK-ALIGN hardware and replace with a new left side QUIK-ALIGN service kit, see Parts List Section of this publication.
13. Tighten the QUIK-ALIGN locknut to 100 foot pounds (135 Nm). This will hold the eccentric flanged washer (see Figure 7-6) in place against the hanger face and within the adjustment guide, but loose enough to permit the eccentric flanged washer to rotate freely.
14. Using an alignment tool or ½" (13 mm) square drive breaker bar, rotate the left eccentric alignment collar to align axle (Clockwise rotation moves axle forward, counter clockwise rotation moves axle rearward). A 90° rotation of the QUIK-ALIGN collar will move axle fore and aft ± ½" (13 mm) from center.

**WARNING**

DO NOT ASSEMBLE THE QUIK-ALIGN JOINT WITHOUT THE PROPER FASTENERS. USE ONLY H-COATED FASTENERS TO SUSTAIN PROPER CLAMP FORCE. FAILURE TO DO SO CAN CAUSE LOSS OF VEHICLE CONTROL, PROPERTY DAMAGE OR PERSONAL INJURY AND VOID WARRANTY. ENSURE THAT THE QUIK-ALIGN FASTENER'S TORQUE VALUES ARE SUSTAINED AS RECOMMENDED IN THE TORQUE SPECIFICATIONS SECTION OF THIS PUBLICATION. FAILURE TO DO SO CAN CAUSE LOSS OF VEHICLE CONTROL RESULTING IN PERSONAL INJURY OR PROPERTY DAMAGE.

15. Measure from the straight edge to the forward face of the axle arm to verify both sides of axle are equal and tighten the QUIK-ALIGN locknuts to 525-575 foot pounds (712-780 Nm) torque, see Figure 7-6.

**FIGURE 7-6**



**NOTE**

The Eccentric collar (1 per suspension) is located on the outside of the left frame hanger. The concentric collars (3 per suspension) are located on the inside of the left frame hanger and both outside and inside of the right frame hanger.

**NOTE**

Axle adjustment is applied to the LEFT side of the vehicle only. If adjustment to the right side of the vehicle is necessary, it will require replacement of the outside concentric collar with an eccentric collar and repeat Steps 6 to 10 on the right side of the vehicle.

16. Following alignment of axle, move vehicle back and forth several times prior to removing straight edge from frame, and recheck measurements to confirm adjustments.
17. Repeat Steps 10 to 15 until alignment is achieved.
18. After the drive axle is aligned, check the pinion angle of drive axle with a digital protractor, see Figure 7-4. Refer to the vehicle manufacturer specifications for the required pinion angles.
  - a. If the pinion angles are within the vehicle manufacturer's specifications then proceed to Step 19.
  - b. If any pinion angle is out of the vehicle manufacturer's specifications it must be corrected. Contact vehicle manufacturer.
19. When all drive axle alignments and pinion angles are within the vehicle manufacturer's specifications then the alignment procedure is complete.

## SECTION 8

# Component Replacement

### FASTENERS

Hendrickson recommends when servicing the vehicle, replace all removed fasteners with new equivalent fasteners. Maintain correct torque values at all times. Check torque values as specified. See Hendrickson's Torque Specifications Section in this publication. If non-Hendrickson fasteners are used follow torque specifications listed in the vehicle manufacturer's service manual.

### HEIGHT CONTROL VALVE

#### DISASSEMBLY

1. Chock the wheels of the vehicle.
2. Raise frame of vehicle to remove load from suspension.

**WARNING**

VEHICLE MUST BE FIRMLY SUPPORTED WITH JACK STANDS PRIOR TO SERVICING. FAILURE TO DO SO CAN RESULT IN PERSONAL INJURY OR PROPERTY DAMAGE.

3. Remove the height control valve's linkage assembly from the height control valve arm and lower mounting bracket by sliding the rubber grommets off their studs.

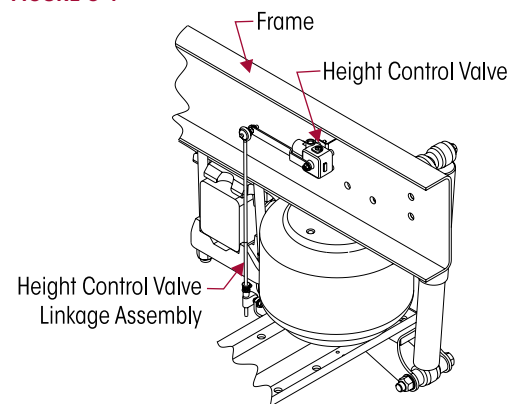
**WARNING**

PRIOR TO AND DURING DEFLATION AND INFLATION OF THE AIR SUSPENSION SYSTEM, ENSURE THAT ALL PERSONNEL AND EQUIPMENT ARE CLEAR FROM UNDER THE VEHICLE AND AROUND THE SERVICE AREA, FAILURE TO DO SO CAN CAUSE SERIOUS PERSONAL INJURY, DEATH, OR PROPERTY DAMAGE.

4. See additional Air Spring Cautions and Warnings in the Important Safety Notice Section of this publication prior to deflating or inflating the air system.
5. Lower the height control valve arm to exhaust the air in the air springs and deflate the rear suspension.
6. Remove the  $\frac{5}{16}$ " fasteners that attach the extension rod to the height control valve arm.
7. Remove the air lines from the height control valve.

8. Remove the air fittings from the height control valve.
9. Remove the  $\frac{1}{4}$ " fasteners that attach the height control valve to the frame mounting bracket.
10. Remove the height control valve, see Figure 8-1.

**FIGURE 8-1**

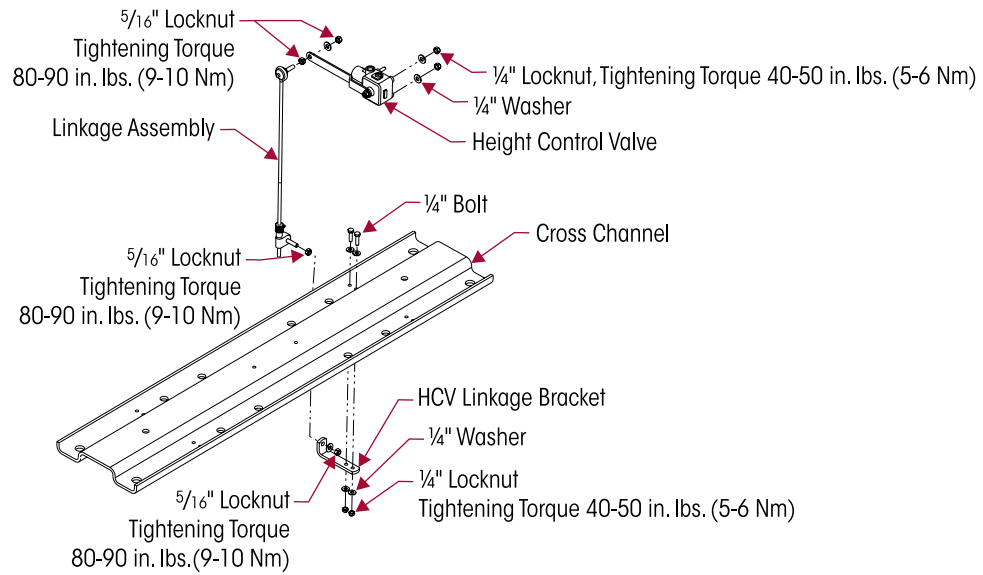


#### ASSEMBLY

1. Install the height control valve to the frame mounting bracket by attaching the  $\frac{5}{16}$ " washers and locknuts. Tighten to 80-90 inch pounds (9-10 Nm) torque, see Figure 8-2.
2. Re-install the air fittings into the height control valve. Ensure the Teflon® thread sealing ring is seated around the base of the fitting's hex shoulder. Tighten to 3-15 foot pounds (4-20 Nm) torque.
3. Install the height control valve link assembly to the height control valve arm by attaching the  $\frac{5}{16}$ " washer and locknut. Tighten to 80-90 inch pounds (9-10 Nm) torque, see Figure 8-2.



FIGURE 8-2



4. Install the height control valve linkage bracket to the cross channel by attaching the 1/4" fasteners. Tighten to 40-50 inch pounds (5-6 Nm) torque, see Figure 8-2.
5. Install the air lines to the height control valve. Refer to the Plumbing Diagram Section of this publication.
6. See additional Air Spring Cautions and Warnings in the Important Safety Notice Section of this publication prior to deflating or inflating the air system.
7. Inflate the suspension by connecting the height control valve linkage to the height control valve arm. Verify the air springs inflate uniformly without binding.
8. Remove the frame supports.
9. Remove the wheel chocks.
10. Verify the vehicle's ride height is within specifications, adjust as necessary, see Ride Height Adjustment in Alignment & Adjustments Section of this publication.

## AIR SPRING

### DISASSEMBLY

1. Chock the front wheels.
2. Raise and support the frame of the vehicle at ride height.



### WARNING

THE VEHICLE MUST BE FIRMLY SUPPORTED WITH JACK STANDS PRIOR TO SERVICING. FAILURE TO DO SO CAN RESULT IN PERSONAL INJURY OR PROPERTY DAMAGE.

3. Disconnect the height control linkage assembly from the height control valve arm by sliding the rubber grommet from the stud.



### WARNING

PRIOR TO AND DURING DEFLATION AND INFLATION OF THE AIR SUSPENSION SYSTEM, ENSURE THAT ALL PERSONNEL AND EQUIPMENT ARE CLEAR FROM UNDER THE VEHICLE AND AROUND THE SERVICE AREA, FAILURE TO DO SO CAN CAUSE SERIOUS PERSONAL INJURY, DEATH, OR PROPERTY DAMAGE.

4. See additional Air Spring Cautions and Warnings in the Important Safety Notice Section of this publication prior to deflating or inflating the air system.
5. Lower the height control valve arm to exhaust the air in the air springs and deflate the rear suspension.
6. Remove the air line from the air spring.
7. Remove air fittings from air spring.



8. Remove the ½" lower air spring fasteners that connect air spring to the cross channel, see Figure 8-3.
9. Remove the ½" fasteners that connect air spring to the upper air spring hanger.
10. Remove the air spring.

### INSPECTION

1. Inspect the mounting surfaces and lower air spring mount for any damage. Replace as necessary.
2. Inspect upper air spring bracket for cracks. Replace as necessary.

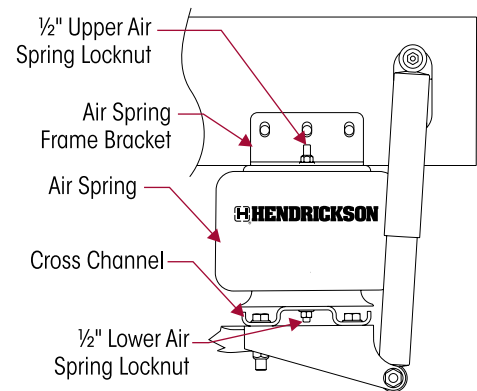
### ASSEMBLY

1. Install the air spring between the frame and cross channel, see Figure 8-3.

### CAUTION

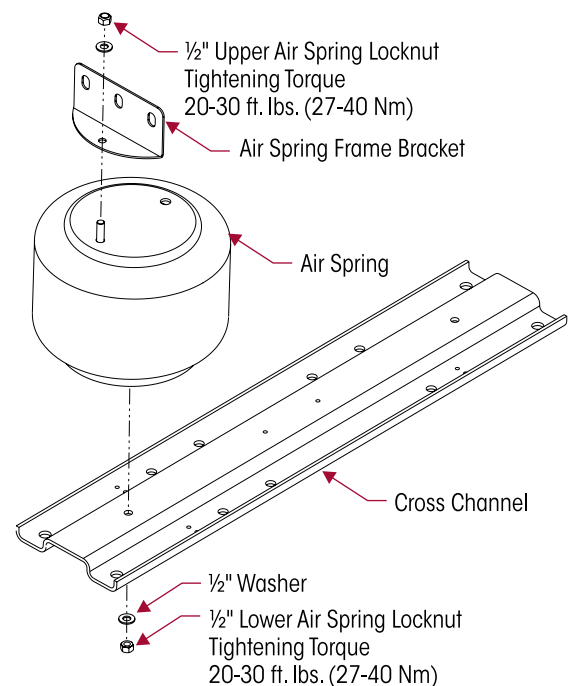
FAILURE TO PRESS THE AIR SPRING AGAINST THE UNDERSIDE OF THE FRAME WHILE TIGHTENING THE UPPER AIR SPRING BRACKET CAN RESULT IN COMPONENT DAMAGE AND PERSONAL INJURY OR PROPERTY DAMAGE.

**FIGURE 8-3**



2. Install the air spring lower mounting stud through the cross channel hole. Attach the ½" fasteners to the lower mounting stud of the air spring. **USING HAND TOOLS ONLY**, tighten the locknut to 20-30 foot pounds (27-40 Nm) torque, see Figure 8-4.
3. Install the air spring to air spring upper frame bracket. Tighten the locknut to 20-30 foot pounds (27-40 Nm) torque, see Figure 8-4.
4. Re-install the air fittings. Ensure the Teflon® thread sealing ring is seated around the base of the fitting's hex shoulder. Tighten to 3-15 foot pounds (4-20 Nm) torque.
5. Connect the air line to the air spring.
6. See additional Air Spring Cautions and Warnings in the Important Safety Notice Section of this publication prior to deflating or inflating the air system.
7. Inflate the suspension by connecting the height control valve linkage to the height control valve arm. Verify the air springs inflate uniformly without binding.
8. Remove the frame supports.
9. Remove the wheel chocks.
10. Verify the vehicle's ride height is within specifications. Adjust as necessary, see Ride Height Adjustment in Alignment & Adjustments Section of this publication.

**FIGURE 8-4**

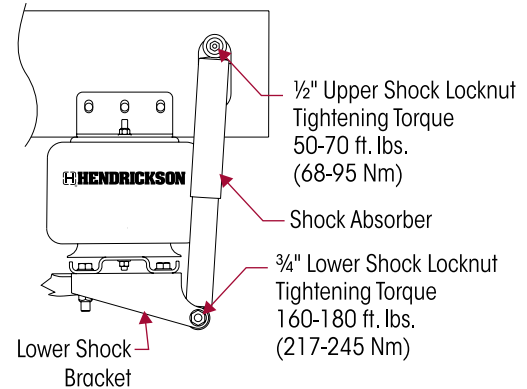


## SHOCK ABSORBER



### DISASSEMBLY

1. Chock the wheels of the vehicle.
2. Remove the ½" fasteners, that connect shock absorber to frame hanger, see Figure 8-5.
3. Remove the ¾" fasteners that connect shock absorber to lower shock bracket, see Figure 8-5.
4. Slide the shock absorber out of the lower mounting bracket.
5. Remove the shock absorber from the upper mounting stud.
6. Inspect the shock absorber mounting brackets and hardware for damage or wear, and replace as necessary, see the Preventive Maintenance Section of this publication.

FIGURE 8-5



### ASSEMBLY

1. Install shock absorber to frame bracket stud by attaching ½" washers and locknut.
2. Install shock absorber to lower shock bracket by attaching the ¾" bolt, washers, and locknut.
3. Tighten ½" locknut to  50-70 foot pounds (68-95 Nm) torque, and ¾" locknut to  160-180 foot pounds (217-245 Nm) torque, see Figure 8-5.
4. Remove the frame supports.
5. Remove the wheel chocks.
6. Verify the vehicle's ride height is within specifications. Adjust as necessary, see Ride Height Adjustment in Alignment & Adjustments Section of this publication.

## SHOCK ABSORBER LOWER MOUNTING BRACKET

### DISASSEMBLY

1. Chock the front wheels.
2. Raise and support the frame of the vehicle at ride height.

 **WARNING**

THE VEHICLE MUST BE FIRMLY SUPPORTED WITH JACK STANDS PRIOR TO SERVICING. FAILURE TO DO SO CAN RESULT IN PERSONAL INJURY OR PROPERTY DAMAGE.

3. Disconnect the height control linkage assembly from the height control valve arm by sliding the rubber grommet from the stud.

 **WARNING**

PRIOR TO AND DURING DEFLATION AND INFLATION OF THE AIR SUSPENSION SYSTEM, ENSURE THAT ALL PERSONNEL AND EQUIPMENT ARE CLEAR FROM UNDER THE VEHICLE AND AROUND THE SERVICE AREA, FAILURE TO DO SO CAN CAUSE SERIOUS PERSONAL INJURY, DEATH, OR PROPERTY DAMAGE.

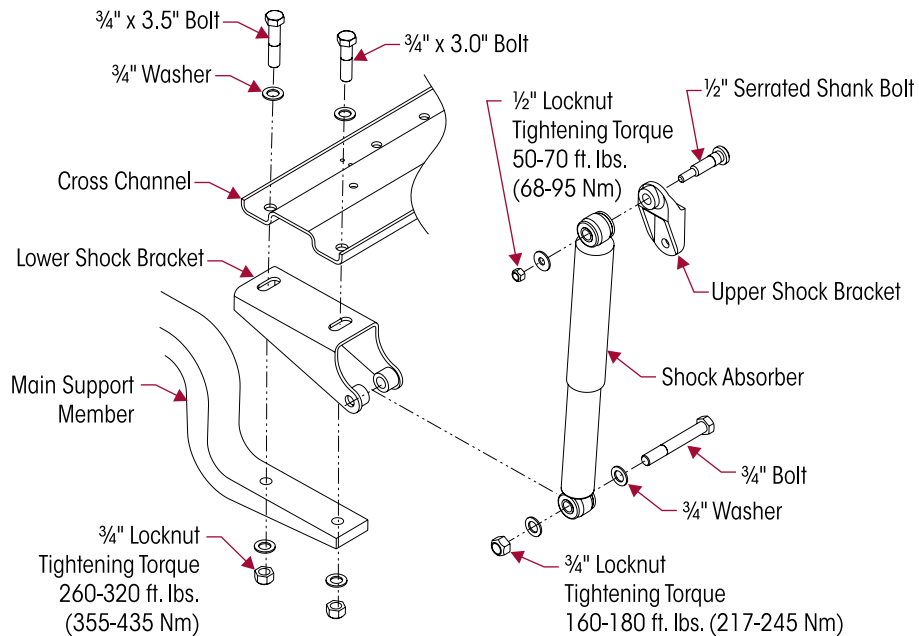
4. See additional Air Spring Cautions and Warnings in the Important Safety Notice Section of this publication prior to deflating or inflating the air system.
5. Lower the height control valve arm to exhaust the air in the air springs and deflate the rear suspension.
6. Remove the air lines from the air springs.
7. Remove the ½" fasteners that connect the shock absorber to the upper frame bracket.
8. Remove the ¾" fasteners that connect the shock absorber to the lower bracket, see Figure 8-6.
9. Slide the shock absorber out of the lower mounting bracket.

10. Using a floor jack under the center of the cross channel, raise the cross channel slightly.
11. Remove the  $\frac{3}{4}$ " fasteners that connect the cross channel and lower shock bracket to the main support member assembly on the affected side. Loosen the  $\frac{3}{4}$ " bolts, washers and locknuts on the opposite side.
12. Remove lower shock bracket.

### INSPECTION

1. Inspect the shock absorber mounting brackets for damage or wear, and replace as necessary, see the Preventive Maintenance Section of this publication.

**FIGURE 8-6**

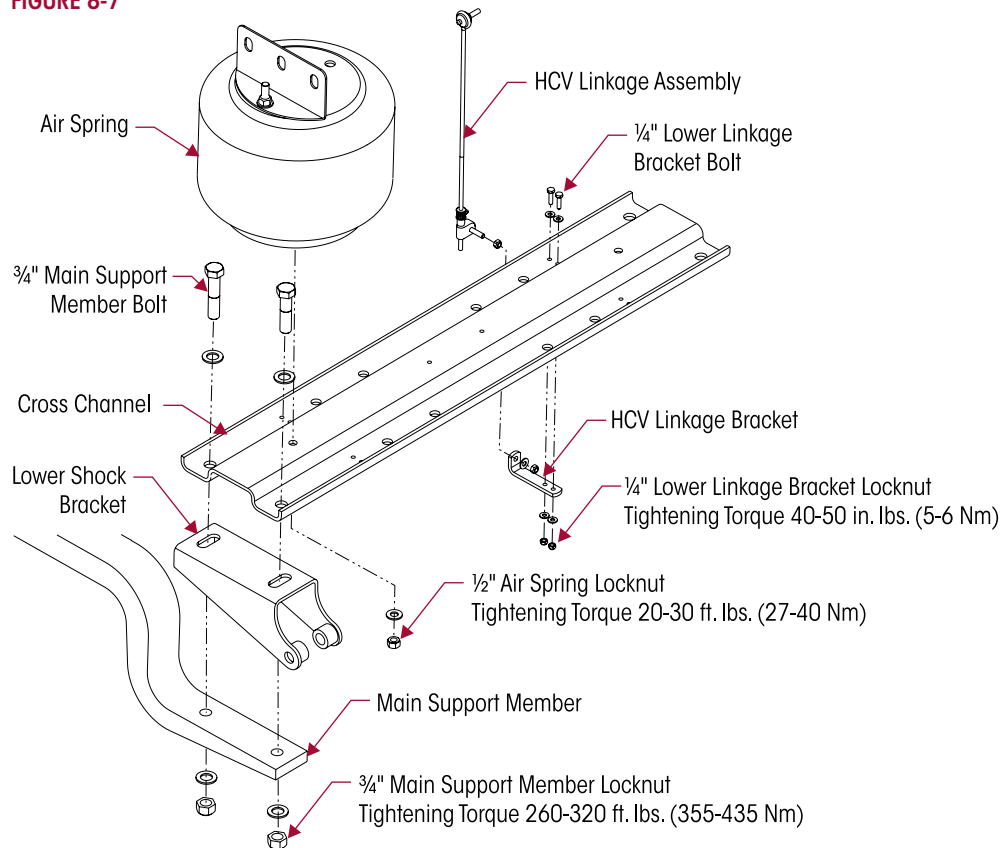


### ASSEMBLY

1. Install the lower shock absorber mounting bracket over the end of the main support member.
2. Lower the cross channel on top of the main support member and the lower shock absorber mounting bracket.
3. Loosely install the two  $\frac{3}{4}$ " bolt and washer through the cross channel holes, lower shock bracket and main support member on each end of the cross channel, see Figure 8-6.
4. Install  $\frac{3}{4}$ " on the cross channel bolts. Tighten the cross channel fasteners to 260-320 foot pounds (355-435 Nm) torque.
5. Slide the shock absorber lower mount into the lower shock absorber mounting bracket.
6. Install the  $\frac{3}{4}$ " fasteners through the lower shock absorber mount and lower shock bracket. Tighten the fasteners to 160-180 foot pounds (217- 245 Nm) torque, see Figure 8-6.
7. Reconnect the air lines to the air springs.
8. See additional Air Spring Cautions and Warnings in the Important Safety Notice Section of this publication prior to deflating or inflating the air system.
9. Inflate the suspension by connecting the height control valve linkage to the height control valve arm. Verify the air springs inflate uniformly without binding.
10. Remove the frame supports.
11. Remove the wheel chocks.
12. Verify the vehicle's ride height is within specifications. Adjust as necessary, see Ride Height Adjustment in Alignment & Adjustments Section in this publication.

## CROSS CHANNEL

FIGURE 8-7



### DISASSEMBLY

1. Chock the front wheels.
2. Support the frame of the vehicle at ride height.



### WARNING

THE VEHICLE MUST BE FIRMLY SUPPORTED WITH JACK STANDS PRIOR TO SERVICING. FAILURE TO DO SO CAN RESULT IN PERSONAL INJURY OR PROPERTY DAMAGE.

3. Remove the air springs as detailed in the "Air Spring Disassembly" in this section.
4. Remove the 1/4" height control valve linkage bracket fasteners to cross channel. Remove the bracket.
5. Remove the 3/4" bolts from the cross channel to main support member, see Figure 8-7.
6. Remove the cross channel.

### INSPECTION

1. Inspect the mounting surfaces and lower air spring mount for any damage. Replace as necessary.
2. Inspect the upper air spring bracket for cracks. Replace as necessary.
3. Inspect the cross channel for straightness, excessive wear and cracks. Replace as necessary.

### ASSEMBLY

1. Place cross channel on top of the lower shock bracket and main support member.
2. Loosely install the two 3/4" bolt and washer through the cross channel holes, lower shock bracket and main support member on each end of the cross channel, see Figure 8-7.



3. Tighten the cross channel fasteners to 260-320 foot pounds (355-435 Nm) torque, see Figure 8-7.
4. Install the height control valve lower bracket to the cross channel using two ¼" fasteners. Tighten the fasteners to 40-50 inch pounds (5-6 Nm) torque.
5. Install the air spring between the frame and cross channel.



## WARNING

FAILURE TO PRESS THE AIR SPRING AGAINST THE UNDERSIDE OF THE FRAME WHILE TIGHTENING THE UPPER AIR SPRING BRACKET CAN RESULT IN COMPONENT DAMAGE AND PERSONAL INJURY OR PROPERTY DAMAGE.

6. Install the air spring lower mounting stud through the cross channel hole. Attach the ½" fasteners to the lower mounting stud of the air spring. **USING HAND TOOLS ONLY**, tighten the locknut to 20-30 foot pounds (27-40 Nm) torque.
7. Connect the air line to the air spring.
8. See additional Air Spring Cautions and Warnings in the Important Safety Notice Section of this publication prior to deflating or inflating the air system.
9. Inflate the suspension by connecting the height control valve linkage to the height control valve arm. Verify the air springs inflate uniformly without binding.
10. Remove the frame supports.
11. Remove the wheel chocks.
12. Verify the vehicle's ride height is within specifications, adjust as necessary, see Ride Height Adjustment in Alignment & Adjustments Section of this publication.

## TRANSVERSE TORQUE RODS



## WARNING

THE COMFORT AIR SUSPENSION INCORPORATES TRANSVERSE RODS FOR VEHICLE STABILITY. IF THESE COMPONENTS ARE DISCONNECTED OR ARE NON-FUNCTIONAL THE VEHICLE SHOULD NOT BE OPERATED. FAILURE TO DO SO CAN RESULT IN ADVERSE VEHICLE HANDLING AND POSSIBLE TIRE CONTACT WITH THE FRAME. OPERATING A VEHICLE WITH NON-FUNCTIONAL TRANSVERSE RODS CAN RESULT IN LOSS OF VEHICLE CONTROL, SEVERE PERSONAL INJURY, AND PREMATURE COMPONENT DAMAGE.

## DISASSEMBLY

1. Chock the wheels of the vehicle.
2. Support the frame of the vehicle at ride height.



## WARNING

THE VEHICLE MUST BE FIRMLY SUPPORTED WITH JACK STANDS PRIOR TO SERVICING. FAILURE TO DO SO CAN RESULT IN PERSONAL INJURY OR PROPERTY DAMAGE.

## SERVICE HINT

Note the quantity and location of shims removed during disassembly. The same quantity **MUST** be reinstalled in the same location in order to maintain the lateral alignment of the axle prior to disassembly. The lateral alignment procedure will need to be performed after assembly, see Alignment & Adjustments Section of this publication.

3. Remove the 5/8" fasteners that connect the transverse torque rod to the frame bracket and axle.
4. Remove the transverse torque rod.

## INSPECTION

1. Inspect the torque rod mating surfaces for any wear or damage. Repair as necessary.
2. Inspect the rubber bushings for wear or damage, replace as necessary.
3. Inspect the torque rod for straightness, wear, or cracks, replace as necessary.
4. Inspect the inner (if equipped) and outer reinforcement plates for wear or damage, replace as necessary.
5. Inspect the frame rail for wear or damage, repair as necessary.

## ASSEMBLY

### NOTE

Hendrickson recommends the use of Grade 8 bolts and Grade C locknuts be used for all torque rod attachments.

1. Install transverse torque rod by attaching the  $\frac{5}{8}$ " bolts, washers, and locknuts to the frame bracket and axle. See vehicle manufacturer for torque specifications.
2. Verify lateral axle alignment, and correct with drop in shims between the torque rod bar pin and the frame or axle bracket depending on the direction of alignment.
3. Remove wheel chocks.

## TORQUE ROD BUSHING

### DISASSEMBLY

You will need:

- A vertical press with a capacity of at least 10 tons
- A receiving tool, see the Special Tools Section of this publication for shop made tool specifications.



### CAUTION

DO NOT USE HEAT OR USE A CUTTING TORCH TO REMOVE THE BUSHINGS FROM THE TORQUE ROD. THE USE OF HEAT WILL ADVERSELY AFFECT THE STRENGTH OF THE TORQUE ROD; HEAT CAN CHANGE THE MATERIAL PROPERTIES. A COMPONENT DAMAGED IN THIS MANNER CAN RESULT IN THE LOSS OF VEHICLE CONTROL, POSSIBLE PERSONAL INJURY OR PROPERTY DAMAGE AND VOID WARRANTY.

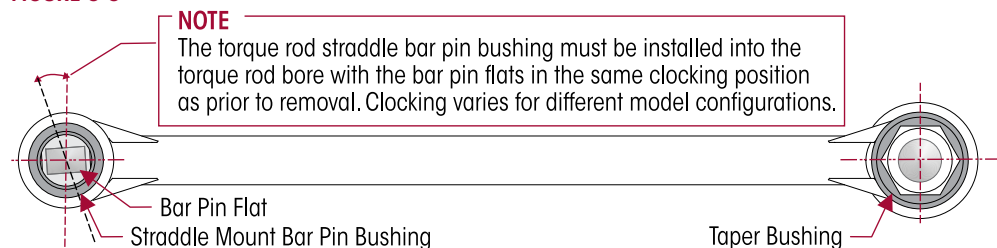
1. Remove the torque rod as detailed in this section.

### SERVICE HINT

When servicing a straddle mount bar pin type bushing assembly, mark the clocking position of the straddle mount bar pin flats on the torque rod end hub before disassembly. This clocking mark will serve as a guide when installing the new bushing assembly so the original clocking position can be retained.

2. When replacing a straddle mount bar pin type bushing assembly, mark the clocking position of the bushing assembly's bar pin flats with a paint stick on the torque rod end hub prior to disassembly, see Figure 8-8.

**FIGURE 8-8**



3. Install the torque rod in the press. Support the torque rod end on the receiving tool with the end of the torque rod centered on the tool. Be sure the torque rod is squarely supported on the press bed.
4. Push directly on the inner metal of the bushing assembly until the bushing assembly clears the torque rod end tube.
5. Clean and inspect the inner diameter of the torque rod ends.

### ASSEMBLY

### NOTE

**DO NOT** use a petroleum or soap base lubricant. Such lubricants can cause adverse reactions with the bushing, such as deterioration of the rubber, causing premature failure.



1. Lubricate the inner diameter of the torque rod end hub and the new rubber bushing with P-80 Lubricant (refer to the Parts List Section of this publication) or light Naphthenic Base Oil, such as 60 SUS at 100°F, see Figure 8-9.
2. Support the torque rod end hub on the receiving tool with the end hub of the torque rod centered on the receiving tool.

**SERVICE HINT**

When replacing a straddle mount bar pin type bushing assembly, verify the correct clocking position of the straddle mount bar pin flats prior to installing the bushing assembly in the torque rod end hub.

3. Verify the bar pin flats are clocked correctly.
4. Press directly on the inner metal of the bushing assembly.

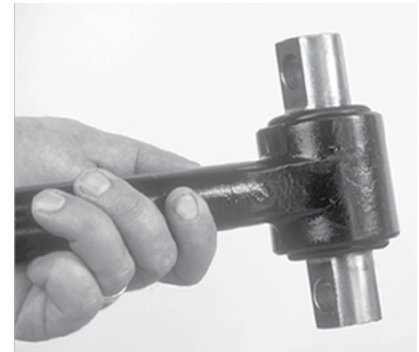
**FIGURE 8-9**



**FIGURE 8-10**



**FIGURE 8-11**



5. When pressing in the new bushings overshoot the desired final position by approximately 3/16", see Figure 8-10.
6. Press the inner metal of the bushing assembly again from opposite side to center the bushing and inner metal within the torque rod end hub, see Figure 8-11.
7. Wipe off excess lubricant. Allow the lubricant four (4) hours to dissipate before operating vehicle.

**CAUTION**

IF THE TORQUE ROD ASSEMBLY IS NOT ALLOWED THE ALLOTTED TIME FOR THE LUBRICANT TO DISSIPATE, THE BUSHING MAY SLIDE FROM THE TORQUE ROD END TUBE. THE BUSHING WILL THEN NEED TO BE REMOVED AND A NEW BUSHING RE-INSTALLED.

8. Install the torque rod assembly as detailed in this section.

**CLAMP GROUP**

- TOP PAD
- SPRING SEAT
- BOTTOM CAP

**WARNING**

THE PROCEDURE TO DISASSEMBLE THE CLAMP GROUP IS DONE WITH THE OTHER MAIN SUPPORT MEMBER PROPERLY CONNECTED TO THE FRAME HANGER AND AXLE. FAILURE TO HAVE THE OTHER MAIN SUPPORT MEMBER CONNECTED PROPERLY COULD ALLOW THE AXLE TO SHIFT RESULTING IN POSSIBLE DAMAGE TO COMPONENTS AND/OR PERSONAL INJURY. IF THE OTHER MAIN SUPPORT MEMBER ISN'T PROPERLY CONNECTED TO THE FRAME HANGER AND AXLE IT WILL BE NECESSARY TO SUPPORT THE AXLE PINION TO KEEP THE AXLE FROM SHIFTING.

**DISASSEMBLY**

1. Chock the front wheels.
2. Support the frame of the vehicle at ride height.

**WARNING**

THE VEHICLE MUST BE FIRMLY SUPPORTED WITH JACK STANDS PRIOR TO SERVICING. FAILURE TO DO SO CAN RESULT IN PERSONAL INJURY OR PROPERTY DAMAGE.

3. Disconnect the height control linkage assembly from the height control valve arm by sliding the rubber grommet from the stud.

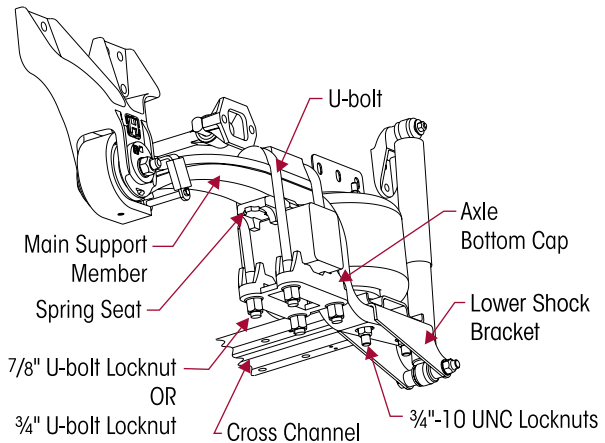


**WARNING**

PRIOR TO AND DURING DEFLATION AND INFLATION OF THE AIR SUSPENSION SYSTEM, ENSURE THAT ALL PERSONNEL AND EQUIPMENT ARE CLEAR FROM UNDER THE VEHICLE AND AROUND THE SERVICE AREA, FAILURE TO DO SO CAN CAUSE SERIOUS PERSONAL INJURY, DEATH, OR PROPERTY DAMAGE.

- See additional Air Spring Cautions and Warnings in the Important Safety Notice Section of this publication prior to deflating or inflating the air system.
- Lower the height control valve arm to exhaust the air in the air springs and deflate the rear suspension.

- On the side being serviced, remove the U-bolt locknuts and washers and discard them, see Figure 8-12.
- Remove the axle bottom cap and top pad.
- Remove fasteners from cross channel on the opposite side from the side being serviced.

**FIGURE 8-12****SERVICE HINT**

Removing the cross channel bolts from the opposite side allows accessibility to the clamp group being serviced without removing the main support member and the air spring.

- Place a floor jack under the cross channel near the main support member being serviced. Raise the cross channel and main support member enough to remove the spring seat from under the main support member.

**INSPECTION**
**WARNING**

FAILURE OF THE MAIN SUPPORT MEMBER BETWEEN THE U-BOLTS WILL REQUIRE THE REPLACEMENT OF THE MAIN SUPPORT MEMBER AND ALL CLAMP GROUP COMPONENTS. FAILURE TO DO SO CAN RESULT IN CLAMP GROUP FAILURE AND FURTHER FAILURE TO THE MAIN SUPPORT MEMBER, WHICH CAN CAUSE LOSS OF VEHICLE CONTROL, PROPERTY DAMAGE OR SEVERE PERSONAL INJURY.

- Inspect the main support member assembly for damage. Replace as necessary.
- Inspect the top pad, spring seat and axle bottom cap for excessive wear and cracks or fretting. Replace as necessary.
- Inspect the axle housing for any cracks or wear. Repair or replace as necessary.

**ASSEMBLY**

- Install the spring seat on the axle housing making sure to engage the alignment locator on the axle housing with the hole in the bottom of the spring seat. Verify the thicker end of the spring seat is to the rear of the vehicle.
- Lower the main support member assembly on the spring seat. Ensure the locator hole on the bottom of the main support member engages both the secondary leaf and spring seat locator holes.
- Install top pad on the top of the main support member assembly. Ensure the locator hole on the bottom of the top pad engages the secondary leaf and main support locator holes.

**WARNING**

U-BOLTS THAT ARE FOUND TO BE LOOSE REQUIRE THAT MATING COMPONENTS BE INSPECTED FOR SIGNS OF WEAR OR FRETTING. ANY COMPONENTS WORN MUST BE REPLACED. FAILURE TO DO SO CAN CAUSE PREMATURE CLAMP GROUP FAILURE, COMPONENT DAMAGE, LOSS OF VEHICLE CONTROL, PROPERTY DAMAGE, OR SEVERE PERSONAL INJURY. MAINTAIN CORRECT TORQUE VALUE AT ALL TIMES. CHECK TORQUE VALUES ON A REGULAR BASIS AS SPECIFIED.



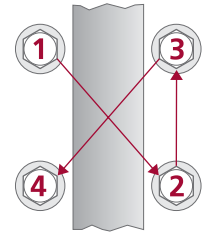


4. Install **NEW** U-bolts, spherical washers, flat washers, and locknuts.
5. Verify that the top pad and bottom cap are installed correctly.
6. Lower the cross channel onto the opposite side lower shock bracket and main support member. Install the two 3/4" bolt and washers through the cross channel, lower shock bracket and main support member. Loosely install the 3/4" locknuts and washers. **DO NOT** tighten at this time.

**WARNING**

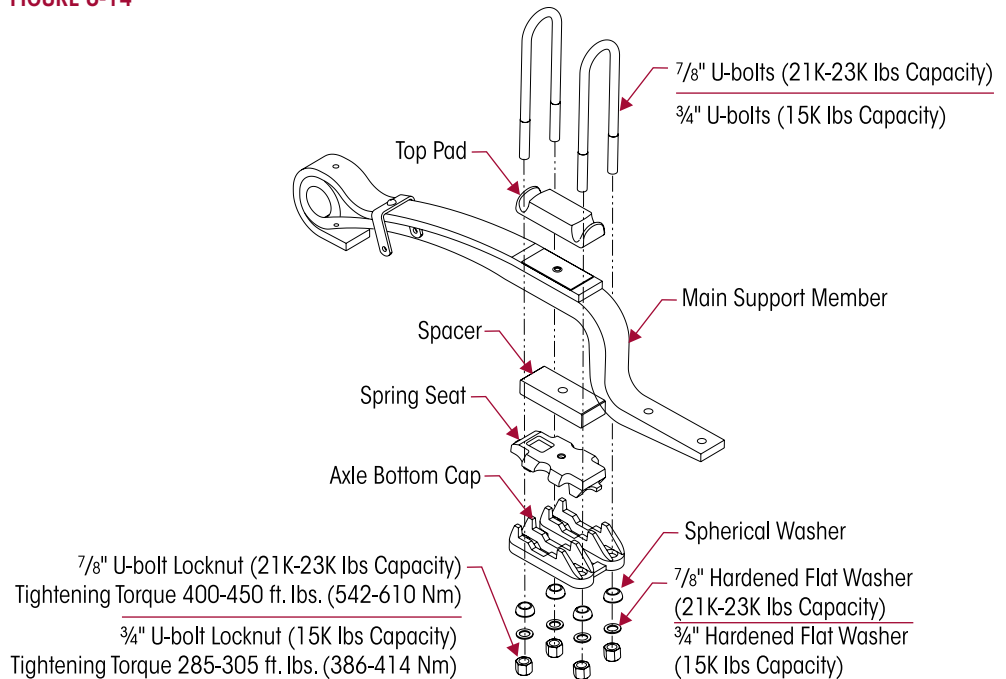
IT IS IMPORTANT THAT THE U-BOLT CLAMP GROUP CONNECTION BE PROPERLY ALIGNED AND HAVE THE PROPER TIGHTENING TORQUE VALUES MAINTAINED. METAL SURFACES CAN WORK AND WEAR AGAINST OTHER RELATED CLAMP GROUP COMPONENTS IF NOT PROPERLY ALIGNED OR PROPERLY TIGHTENED TO MAINTAIN THE PROPER CLAMP FORCE. FAILURE TO DO SO CAN CAUSE PREMATURE COMPONENT WEAR, POSSIBLE SEPARATION OF THE CLAMP GROUP, CAUSING LOSS OF VEHICLE CONTROL, PROPERTY DAMAGE, OR PERSONAL INJURY.

FIGURE 8-13



7. Verify that the U-bolts are seated properly in the channels of the top pad, see Figure 8-14.
8. Verify the secondary leaf and main support member are centered in the frame hanger.
9. Snug U-bolts prior to tightening, applying a crisscross pattern, (approximately  $\square$  100 foot pounds (136 Nm) tightening torque), see Figure 8-13.
10. Tighten the cross channel fasteners to  $\square$  260-320 foot pounds (355-435 Nm) torque.
11. Tighten the U-bolt locknuts evenly to:
  - 7/8" locknuts (21K to 23K pound capacity) to  $\square$  400-450 foot pounds (542-610 Nm) torque
  - 3/4" locknuts (15K pound capacity) to  $\square$  285-305 foot pounds (386-414 Nm) torque, see Figure 8-14.

FIGURE 8-14



12. Rap the top of the U-bolts with a dead blow mallet, and retighten to specified torque. **DO NOT** exceed specified torque on U-bolt locknuts.



13. See additional Air Spring Cautions and Warnings in the Important Safety Notice Section of this publication prior to deflating or inflating the air system.
14. Inflate the suspension by connecting the height control valve linkage to the height control valve arm. Verify the air springs inflate uniformly without binding.
15. Remove the frame supports.
16. Remove the wheel chocks.
17. Verify the vehicle's ride height is within specifications. Adjust as necessary, see Ride Height Adjustment in Alignment & Adjustments Section of this publication.
18. Align the vehicle. Alignment is necessary anytime the main support member is removed to complete the repair, see Alignment & Adjustments Section of this publication.

## MAIN SUPPORT MEMBER

The main support member assembly should function satisfactorily during normal vehicle operation. Replacement is only required when the main support member assembly is damaged or worn.

### CAUTION

THIS PROCEDURE TO REPLACE A MAIN SUPPORT MEMBER IS DONE WITH THE OTHER MAIN SUPPORT MEMBER PROPERLY CONNECTED TO THE FRAME HANGER AND AXLE. FAILURE TO HAVE THE OTHER MAIN SUPPORT MEMBER CONNECTED PROPERLY COULD ALLOW THE AXLE TO SHIFT RESULTING IN POSSIBLE DAMAGE TO COMPONENTS AND/OR PERSONAL INJURY. IF BOTH MAIN SUPPORT MEMBERS ARE TO BE REMOVED IT WILL BE NECESSARY TO SUPPORT THE AXLE PINION TO KEEP THE AXLE FROM SHIFTING.

### DISASSEMBLY

1. Chock the front wheels.
2. Support the frame of the vehicle at ride height.

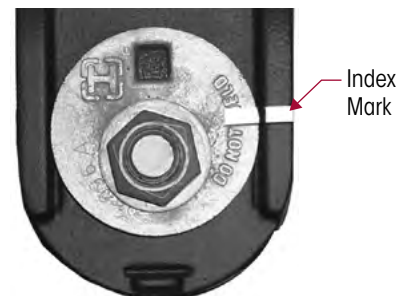
### WARNING

THE VEHICLE MUST BE FIRMLY SUPPORTED WITH JACK STANDS PRIOR TO SERVICING. FAILURE TO DO SO CAN RESULT IN PERSONAL INJURY OR PROPERTY DAMAGE.

3. Disconnect the height control linkage assembly from the height control valve arm by sliding the rubber grommet from the stud.
4. Remove the air springs and cross channel as detailed in the Air Spring and Cross Channel Disassembly instructions in this section.
5. Lift and rotate the shock absorber and lower mounting bracket away from the main support assembly.

6. Mark the position of the QUIK-ALIGN collar relative to the frame hanger, see Figure 8-15.

FIGURE 8-15

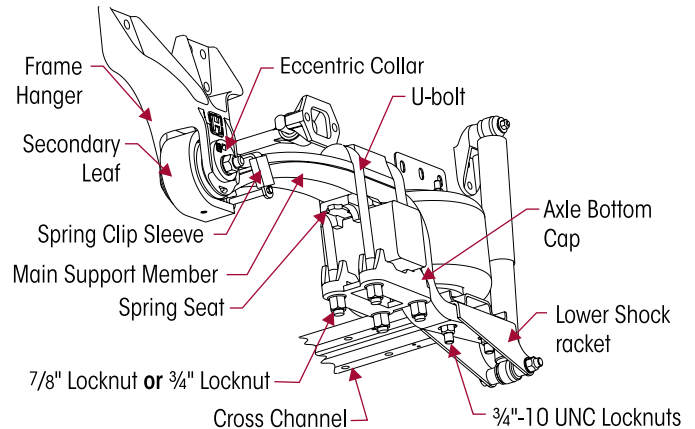


### SERVICE HINT

Marking the position of the QUIK-ALIGN collar will create a starting point for the alignment procedure following reassembly.

7. On the side being serviced, remove and discard the U-bolts locknuts and washers.
8. Remove the axle bottom cap and top pad. Lift the back of the main support member assembly and remove the axle seat from under main support member. Lower the main support member onto the axle housing.
9. Support the main support member by placing a hydraulic jack under the pivot bushing.

10. Remove the pivot bolt, nut and QUIK-ALIGN collars that connect the main support member assembly to the frame hanger, see Figure 8-16.
11. Slide the pivot bushing down and out of the frame hanger. Remove the main support assembly.

**FIGURE 8-16**


### INSPECTION

**WARNING**

U-BOLTS THAT ARE FOUND TO BE LOOSE REQUIRE THAT MATING COMPONENTS BE INSPECTED FOR SIGNS OF WEAR OR FRETTING. ANY COMPONENTS WORN MUST BE REPLACED. FAILURE TO DO SO CAN CAUSE PREMATURE CLAMP GROUP FAILURE, COMPONENT DAMAGE, LOSS OF VEHICLE CONTROL, PROPERTY DAMAGE, OR SEVERE PERSONAL INJURY. MAINTAIN CORRECT TORQUE VALUE AT ALL TIMES. CHECK TORQUE VALUES ON A REGULAR BASIS AS SPECIFIED.

1. Clean any dirt and debris from the QUIK-ALIGN slots in the hangers. Inspect the frame hanger for excessive wear, cracks and proper frame hanger fastener torque. Replace as necessary.
2. Inspect the main support member for damage. Replace as necessary.
3. Inspect the top pad, spring seat and axle bottom cap for excessive wear and cracks or fretting. Replace as necessary.
4. Inspect the axle housing for any cracks or wear. Repair or replace as necessary.
5. Inspect the cross channel for straightness, excessive wear and cracks. Replace as necessary.
6. Inspect the air spring for damage. Inspect the lower piston and the upper air spring mount for cracks.
7. Inspect the shock absorber for leaks and the mounts for excessive wear, cracks, and proper frame hanger fastener torque. Replace as necessary.

### ASSEMBLY

**WARNING**

DO NOT STRIKE SUSPENSION COMPONENTS WITH A HAMMER. DO NOT NICK OR GOUGE THE MAIN SUPPORT MEMBER. SUCH IMPROPER ACTIONS CAN CAUSE DAMAGE; THE MAIN SUPPORT MEMBER ASSEMBLY COULD FAIL, AND CAUSE LOSS OF VEHICLE CONTROL AND POSSIBLE PERSONAL INJURY OR PROPERTY DAMAGE.

1. Position the main support member assembly on spring seat, or on spacer plate (if equipped), with the main support member assembly center locator piloting into hole in spring seat or spacer plate. Galvanized steel liner must be positioned on the topside of the main support member assembly.
2. Align the bushing of the main support member assembly under the opening of the frame hanger and jack into place.

**WARNING**

DO NOT ASSEMBLE QUIK-ALIGN JOINT WITHOUT THE PROPER FASTENERS. USE ONLY H-COATED FASTENERS TO SUSTAIN PROPER CLAMP FORCE. FAILURE TO DO SO CAN CAUSE LOSS OF VEHICLE CONTROL, PROPERTY DAMAGE OR PERSONAL INJURY AND VOID WARRANTY. ENSURE THAT THE QUIK-ALIGN FASTENER'S TORQUE VALUES ARE SUSTAINED AS RECOMMENDED IN THE TORQUE SPECIFICATIONS SECTION OF THIS PUBLICATION. FAILURE TO DO SO CAN CAUSE LOSS OF VEHICLE CONTROL RESULTING IN PERSONAL INJURY OR PROPERTY DAMAGE.

3. Install NEW QUIK-ALIGN collars and fasteners and tighten to 100 foot pounds of torque.

**NOTE**

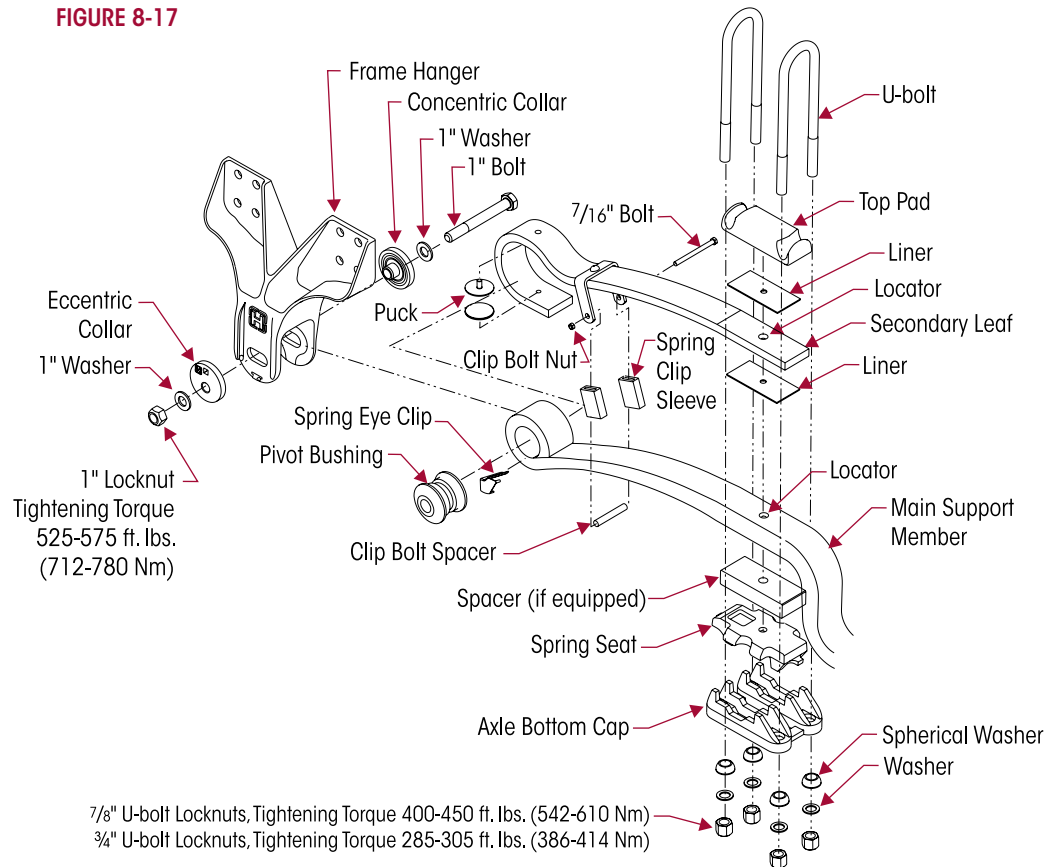
Ensure that QUIK-ALIGN eccentric collar is on the outboard side of the frame hanger. Verify that the nose of each QUIK-ALIGN collar is installed correctly into bushing sleeve, and the flanged side is flat against the frame hanger face within the alignment guides, see Figure 8-17.

4. Raise the rear of the main support member assembly and install the spring seat on the axle, engaging the locator holes.
5. Lower the main support member assembly onto the spring seat. Ensure the locator engages the locator hole in the spring seat.

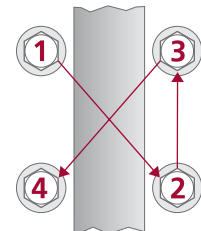
**SERVICE HINT**

It may be necessary to rotate the QUIK-ALIGN eccentric collar to move the main support member assembly forward or rearward in order to engage the locator hole.

6. Install the liners, top pad, bottom axle cap, U-bolts, washers, and fasteners. Ensure all locators are engaged. Verify that the top pad and bottom cap are installed correctly, see Figure 8-17.
7. Verify that the U-bolts are seated properly in the channels of the top pad, see Figure 8-17.

**FIGURE 8-17****FIGURE 8-18**

8. Snug U-bolts in a crisscross pattern, approximately 100 foot pounds (136 Nm) tightening torque, see Figure 8-18.
9. Install the shock absorber and the lower shock bracket onto the rear of the main support member assembly, see Figure 8-19.
10. Install the cross channel onto the rear of the main support member assemblies. Loosely install the cross channel retaining fasteners, see Figure 8-19.

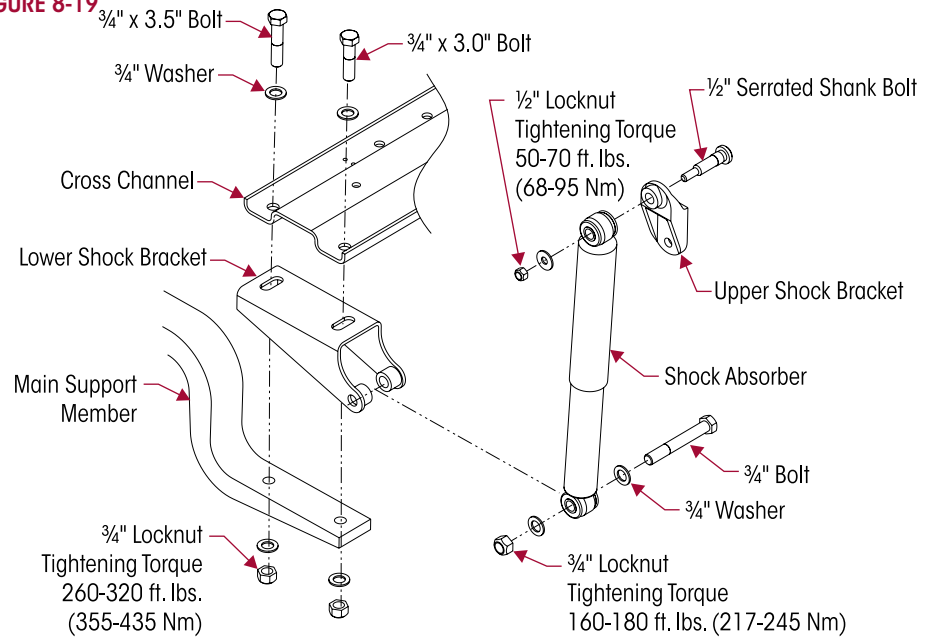
**SERVICE HINT**

It may be necessary to loosen the U-bolts in order to align the cross channel holes with the main support member assemblies. **DO NOT** strike suspension components with a hammer.

**NOTE**

Prior to tightening the QUIK-ALIGN fasteners, U-bolts, or cross channel fasteners to specifications, it is mandatory that the vehicle be positioned at the proper ride height.

11. Tighten the cross channel fasteners to 260-320 foot pounds (355-435 Nm) torque., see Figure 8-19.

**FIGURE 8-19**


12. Tighten the U-bolt locknuts evenly to:
- $\frac{7}{8}$ " locknuts (21K to 23K pound capacity) to 400-450 foot pounds (542-610 Nm) torque, see Figure 8-17.
  - $\frac{3}{4}$ " locknuts (15K pound capacity) to 285-305 foot pounds (386-414 Nm) torque, see Figure 8-17.
13. Rap the top of the U-bolts with a dead blow mallet, and retighten to specified torque. **DO NOT EXCEED SPECIFIED TORQUE ON U-BOLT LOCKNUTS.**
14. Install the air spring lower mounting stud through the cross channel hole. Attach the  $\frac{1}{2}$ " fasteners to the lower mounting stud of the air spring. **USING HAND TOOLS ONLY**, tighten the locknut to 20-30 foot pounds (27-40 Nm) torque.
15. See additional Air Spring Cautions and Warnings in the Important Safety Notice Section of this publication prior to deflating or inflating the air system.
16. Inflate the suspension by connecting the height control valve linkage to the height control valve arm. Verify the air springs inflate uniformly without binding.
17. Remove the frame supports.
18. Remove the wheel chocks.
19. Verify the vehicle's ride height is within specifications. Adjust as necessary, see Ride Height Adjustment in Alignment & Adjustments Section of this publication.
20. Verify that the axle is in proper alignment, see the Alignment & Adjustments Section of this publication.
21. After the correct alignment of the axle is verified tighten the QUIK-ALIGN fasteners to 525-575 foot pounds (712-780 Nm) torque.
22. Remove the wheel chocks.

## FRAME HANGER

The frame hanger should function satisfactorily during normal vehicle operation. Replacement is required when the frame hanger has been damaged or worn.

### DISASSEMBLY

1. Chock the front wheels.
2. Raise and support the frame of the vehicle at ride height.

#### WARNING

THE VEHICLE MUST BE FIRMLY SUPPORTED WITH JACK STANDS PRIOR TO SERVICING. FAILURE TO DO SO CAN RESULT IN PERSONAL INJURY OR PROPERTY DAMAGE.

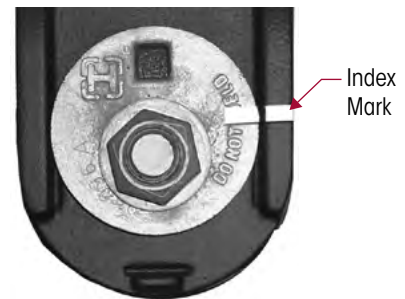
3. Disconnect the height control valve's linkage assembly from the height control valve arm by sliding the rubber grommet from the stud.

#### WARNING

PRIOR TO AND DURING DEFLATION AND INFLATION OF THE AIR SUSPENSION SYSTEM, ENSURE THAT ALL PERSONNEL AND EQUIPMENT ARE CLEAR FROM UNDER THE VEHICLE AND AROUND THE SERVICE AREA, FAILURE TO DO SO CAN CAUSE SERIOUS PERSONAL INJURY, DEATH, OR PROPERTY DAMAGE.

4. See additional Air Spring Cautions and Warnings in the Important Safety Notice Section of this publication prior to deflating or inflating the air system.
5. Lower the height control valve arm to exhaust the air in the air springs and deflate the rear suspension.
6. Mark the position of the QUIK-ALIGN collar relative to the frame hanger, see Figure 8-20.

FIGURE 8-20



### SERVICE HINT

Marking the position of the QUIK-ALIGN collar will create a starting point for the alignment procedure following reassembly.

7. Remove the 1" QUIK-ALIGN locknut and bolt, see Figure 8-21.
8. Remove the QUIK-ALIGN collars that connect the main support member to the frame hanger.
9. Remove the fasteners that attach the frame hanger to the vehicle per the vehicle manufacturer's instructions.
10. Remove the frame hanger.

### INSPECTION

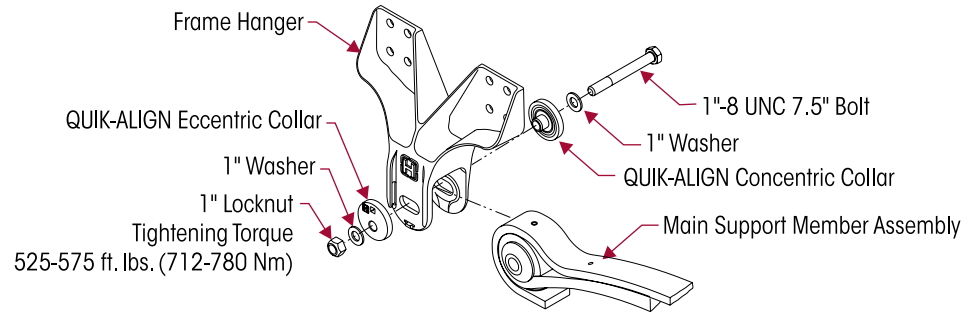
1. Inspect mounting surface of hanger and frame for any damage or wear. Repair or replace as necessary.
2. Inspect the main support member assembly and bushing for wear or damage. Replace as necessary.

### ASSEMBLY

1. Slide the frame hanger over the main support member's bushing.
2. Install new hanger to frame rail fasteners as detailed by the vehicle manufacturer.

#### WARNING

DO NOT ASSEMBLE THE QUIK-ALIGN JOINT WITHOUT THE PROPER FASTENERS. USE ONLY H-COATED FASTENERS TO SUSTAIN PROPER CLAMP FORCE. FAILURE TO DO SO CAN CAUSE LOSS OF VEHICLE CONTROL, PROPERTY DAMAGE OR PERSONAL INJURY AND VOID WARRANTY. ENSURE THAT THE QUIK-ALIGN FASTENER'S TORQUE VALUES ARE SUSTAINED AS RECOMMENDED IN THE TORQUE SPECIFICATIONS SECTION OF THIS PUBLICATION. FAILURE TO DO SO CAN CAUSE LOSS OF VEHICLE CONTROL RESULTING IN PERSONAL INJURY OR PROPERTY DAMAGE.

**FIGURE 8-21**

**NOTE**

Use a new QUIK-ALIGN Kit (see Parts Lists Section of this publication) for any axle alignment or disassembly of the QUIK-ALIGN connection. This ensures that the proper clamp load is applied to the connections, so that the joints will not slip in service.

3. Install NEW QUIK-ALIGN collars and fasteners.

**NOTE**

Ensure that QUIK-ALIGN eccentric collar is on the outboard side of the LEFT frame hanger. Verify that the nose of each QUIK-ALIGN collar is installed correctly into the sleeve of the bushing, and the flanged side is flat against the frame hanger face and within the alignment guides.

4. Align the QUIK-ALIGN collar with the marks made on the frame hanger prior to disassembly. Snug the pivot bolt locknut to approximately 100 foot pounds (136 Nm) of torque.

**NOTE**

Prior to tightening the QUIK-ALIGN locknuts to final torque specifications, it is mandatory that the vehicle be positioned at the proper ride height.

5. See additional Air Spring Cautions and Warnings in the Important Safety Notice Section of this publication prior to deflating or inflating the air system.
6. Inflate the suspension by connecting the height control valve linkage to the height control valve arm. Verify the air springs inflate uniformly without binding.
7. Remove the frame supports.
8. Verify the vehicle's ride height is within specifications. Adjust as necessary, see Ride Height Adjustment in Alignment & Adjustments Section of this publication.
9. Verify that the axle is in proper alignment, see Alignment & Adjustments Section of this publication.
10. After the correct alignment of the axle is verified tighten the QUIK-ALIGN fasteners to 525-575 foot pounds (712-780 Nm) torque, see Figure 8-21.
11. Remove the wheel chocks.



## QUIK-ALIGN PIVOT BUSHING – Using a Shop Press

FIGURE 8-22



### DISASSEMBLY

#### You will need:

- A vertical shop press with a capacity of at least 10 tons.
  - A QUIK-ALIGN pivot bushing installer, remover and receiver tool, see the Special Tools Section of this publication.
1. Remove the  $\frac{7}{16}$ " bolt, clip bolt spacer and nut from the secondary leaf spring clip.
  2. Cut the splicing tape that holds the liners to the center of the main support member assembly and rotate the secondary leaf to clear the spring clip from main support member.
  3. Slide the secondary leaf off of the main support member eye.
  4. Install the main support member in the press. Support the main support member on the receiving tool with the end hub centered on the tool. Be sure the main support member is squarely supported on the press bed, see Figure 8-22.

### NOTE

At the time of manufacture, a spring eye clip was used to insert the bushing into the spring eye of the main support member, see Figures 8-23 and 8-24. If spring eye clip is equipped on the main support member you have the option to carefully press out the bushing from the opposite side of

FIGURE 8-23

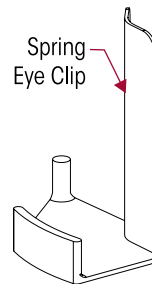
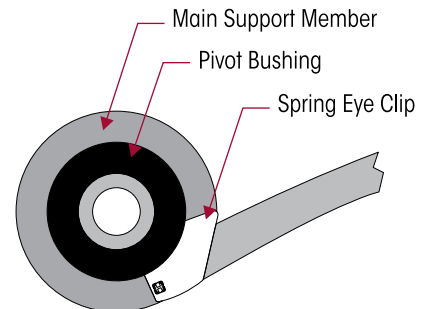


FIGURE 8-24



the spring eye (where the spring eye clip is NOT visible). If the spring eye clip is not damaged it can be used again to facilitate the pressing in of the bushing into the spring eye. If clip is damaged and a replacement (part number 60392-000) is not available, the alternative method is to use the tape option as shown in Figure 8-25.

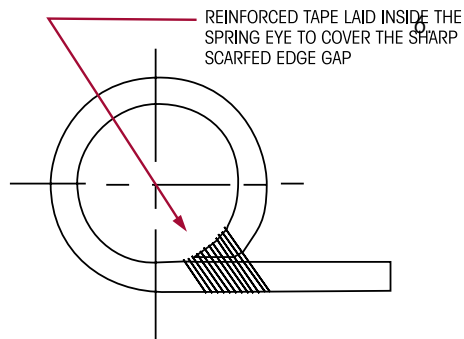
5. Center the push out tool on inner sleeve and press out the old bushing, (these bushings are not cartridge type bushings. They do not have outer metals).
6. Clean and inspect the inner diameter of the main support member eye.

### ASSEMBLY

1. Insert the spring eye clip (if equipped) into the gap of the main support member eye, (see note above). If spring eye clip is damaged and a replacement (Part No. 60392-000) is not available the alternative method is to cut a strip of 3M Scotch #890T black fiber tape, or heavy bodied duct tape 1" x 6" long.
2. Feed the tape into the spring eye, adhesive side facing gap in the eye. Center the tape equally around each end.
3. Pull the tape tight, and wrap it around the outside of the eye. Additional tape may be required depending on gap size. Ensure that the gap is completely covered, see Figure 8-25.



4. Lubricate inner diameter of steel spring bore and the new rubber bushing with P-80 Lubricant (refer to Parts List Section of this publication) or light Naphthenic Base Oil, such as 60 SUS at 100°F. **DO NOT** use petroleum or soap base lubricant, it can cause an adverse reaction with the bushing material, such as deterioration.
5. Install the main support member in the press. Place the main support member on the receiving tool with the end hub centered on the receiving tool. Be sure the main support member is squarely supported on the press bed.

**FIGURE 8-25**

**FIGURE 8-26**


7. Locate the machined pilot of the push out tool on inner sleeve, and press in the new bushing. Bushings must be centered within the spring eye. When pressing in the new bushings, overshoot desired final position by  $\frac{3}{16}$ " and press again from opposite side to center the bushing within the main support member assembly, see Figure 8-26.
8. Trim all protruding tape from the underside of the eye. Wipe off excess lubricant. Allow the lubricant four hours to dissipate before operating vehicle.
9. Replace the two nylon pucks inside the secondary leaf eye.
10. Slide secondary leaf around main support member eye and rotate into position.
11. Place one liner between the secondary leaf and the main support member. Place the second liner on top of the secondary leaf and tape the assembly together using two 1" x 12" long strips of splicing tape.

**CAUTION**

DO NOT WRAP EXCESSIVE TAPE AROUND THE ASSEMBLY AS THIS WOULD CREATE HIGH SPOTS IN THE CLAMP GROUP. DO NOT WRAP TAPE AROUND THE ASSEMBLY MORE THAN TWICE. FAILURE TO DO SO CAN CAUSE PREMATURE WEAR OR DAMAGE TO THE MAIN SUPPORT MEMBER.

12. Install the  $\frac{7}{16}$ " bolt and nut into the spring clip and tighten to 30-34 foot pounds torque.
13. Re-install main support member assembly per instructions in this section.

**QUIK-ALIGN PIVOT BUSHING – Using Tool No. 66086-203L**
**SERVICE HINT**

Use QUIK-ALIGN **Pivot Bushing Tool No. 66086-203L** to help with the installation / removal of the QUIK-ALIGN pivot bushing for COMFORT AIR suspensions. The tool allows the old bushing to be pushed out from the main support member assembly into the receiving cylinder at the same time as installing the new bushing into the main support member assembly.

**WARNING**

A TECHNICIAN USING A SERVICE PROCEDURE OR TOOL WHICH HAS NOT BEEN RECOMMENDED BY HENDRICKSON MUST FIRST SATISFY HIMSELF THAT NEITHER HIS SAFETY NOR THE VEHICLE'S SAFETY WILL BE JEOPARDIZED BY THE METHOD OR TOOL SELECTED. INDIVIDUALS DEVIATING IN ANY MANNER FROM THE INSTRUCTIONS PROVIDED WILL ASSUME ALL RISKS OF CONSEQUENTIAL PERSONAL INJURY OR DAMAGE TO EQUIPMENT INVOLVED.

**To replace the QUIK-ALIGN pivot bushing you will need:**

- A QUIK-ALIGN pivot bushing service tool (Part No. 66086-203L), see Figure 8-27.
- $\frac{3}{4}$ " Impact wrench (impact gun), some  $\frac{1}{2}$ " impact wrenches may work.

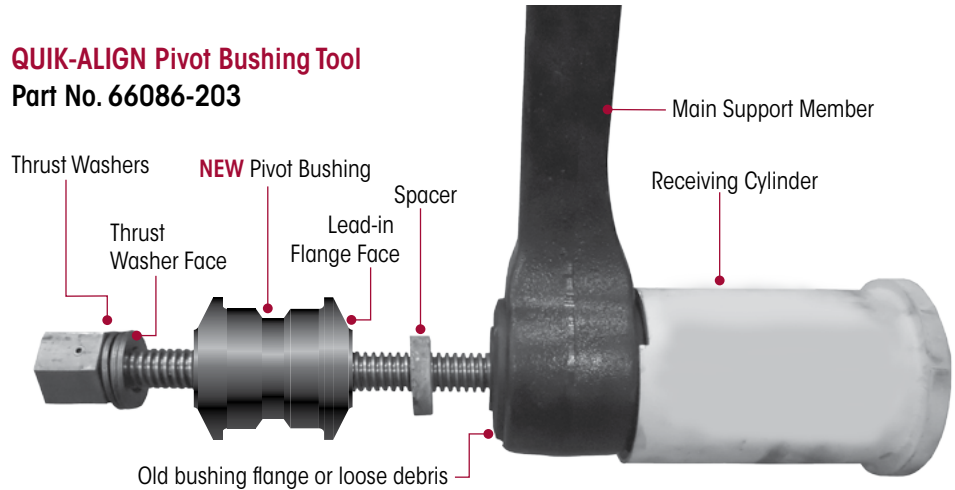
FIGURE 8-27

**NOTE**

Apply NLGI #2-EP chassis lubricant to each face of the thrust washers and to the drive screw that will engage through the receiving cylinder.

Apply P80 lubricant to the face of the lead-in flange and the outer diameter of NEW pivot bushing

**QUIK-ALIGN Pivot Bushing Tool**  
Part No. 66086-203

**DISASSEMBLY**

1. Remove the main support member assembly from the vehicle per the Main Support Member Disassembly procedure in this Section.
2. After removal, place main support member assembly on the floor or suitable work area.

**ASSEMBLY****NOTE**

The 66086-203L tool can be used to remove the old bushing first then install the new bushing, if bore inspection is needed.

1. Install the pivot bushing tool and the NEW pivot bushing as shown in Figure 8-27.
2. Remove any loose rubber or debris from the old bushing.
3. Apply NLGI #2-EP (Extreme Pressure) chassis lubricant to each face of the thrust washers and to the drive screw that will engage through the receiving cylinder.
4. Snug the threaded drive screw to hold the thrust washers, NEW pivot bushing, spacer, main support member assembly with the old pivot bushing and the receiving cylinder in place, see Figure 8-27.

**NOTE**

**DO NOT** use petroleum or soap base lubricant, it can cause an adverse reaction with the bushing material, such as deterioration.

5. Apply P-80 lubricant to the face of the lead-in flange and the outer diameter of NEW pivot bushing. P-80 lubricant is supplied in the QUIK-ALIGN Pivot Bushing Kit No. 34013-103.

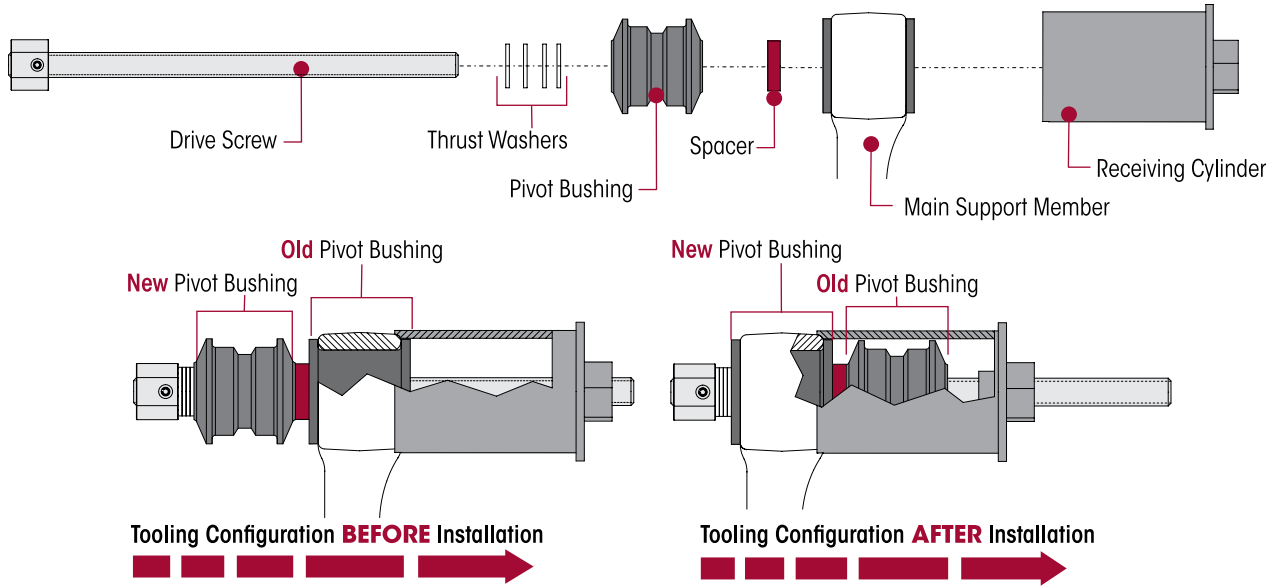
**SERVICE HINT**

To center the pivot bushing within the end hub, it may be necessary to overshoot the desired final position. Then from opposite side, reverse the installation tool and press the pivot bushing again to center the bushing within the beam end hub.

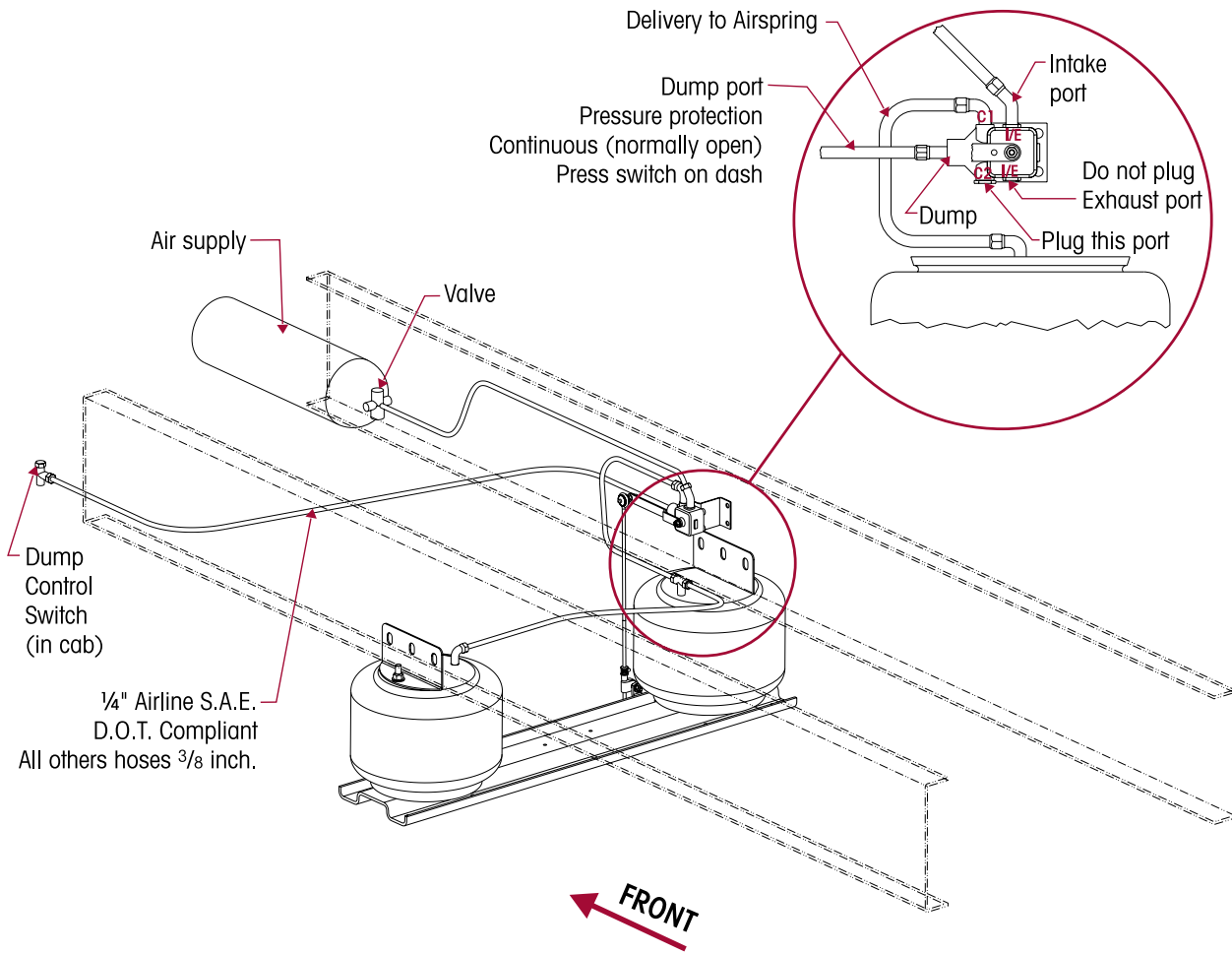
6. Using a  $\frac{3}{4}$ " impact wrench, rotate the drive screw in a continuous motion without stopping until the pivot bushing appears centered in the hub. The old bushing will fall into the receiving cylinder, see Figure 8-28.
7. Using the impact wrench rotate the drive screw in the opposite direction to remove tool.
8. Repeat Steps 1 through 6 for other main support member assembly.
9. Allow the lubricant **four hours** to dissipate before fully operating the vehicle.
10. Install the main support member assembly per the Main Support Member Assembly procedure in this Section.



FIGURE 8-28



# SECTION 9 Plumbing Diagram





## SECTION 10

# Troubleshooting Guide

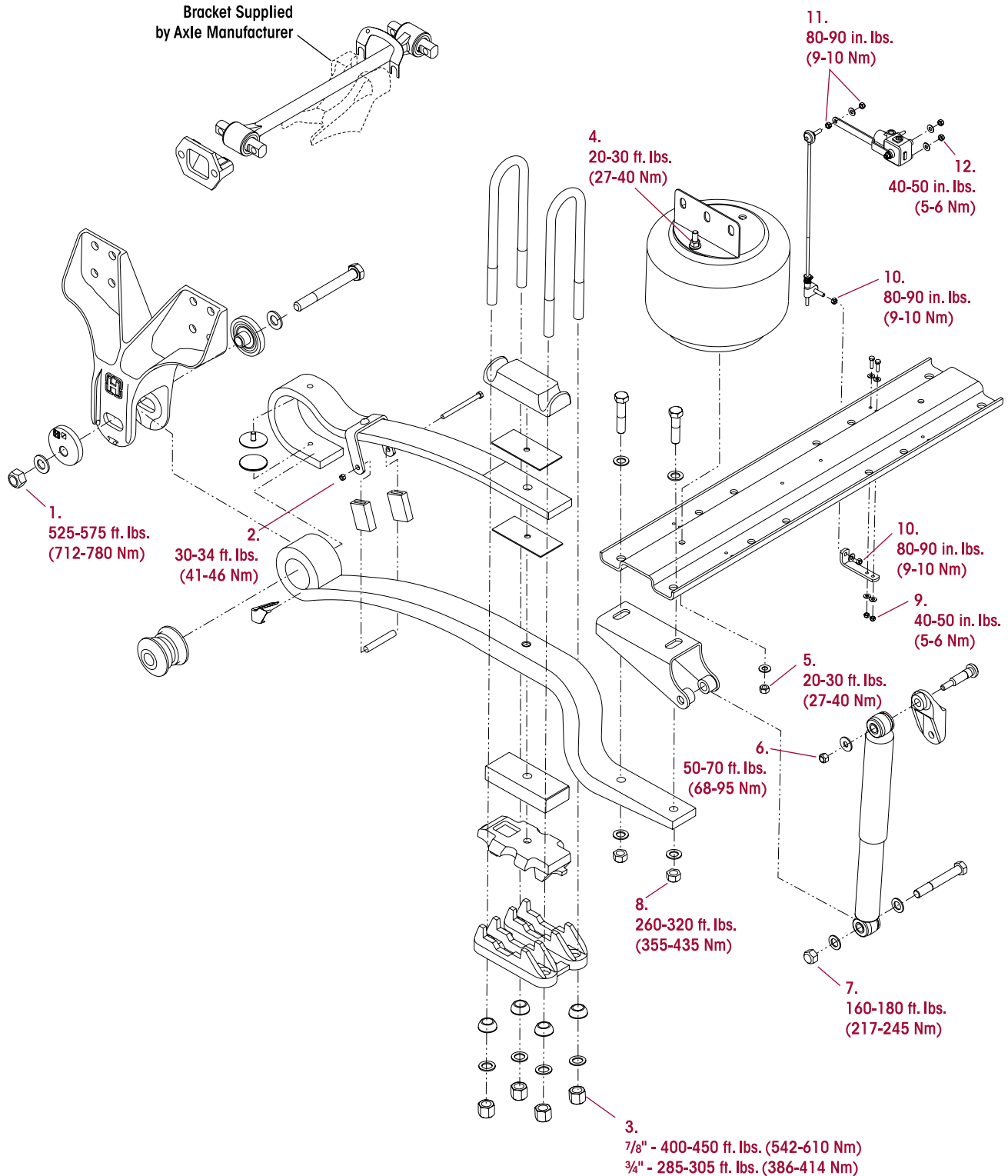
### COMFORT AIR for Blue Bird Buses

TROUBLESHOOTING GUIDE		
CONDITION	POSSIBLE CAUSE	CORRECTION
Vehicle bouncing excessively	Leaking shock absorber	Replace shock absorber.
	Damaged shock absorber	Replace shock absorber.
	Air spring(s) not inflated	Check air supply to air spring, repair as necessary.
	Incorrect ride height	Adjust ride height to proper setting. See Ride Height Adjustment in the Alignment & Adjustments Section of this publication.
Suspension has harsh or bumpy ride	Broken main support member assembly	Replace main support member assembly.
	Damaged height control valve	Replace height control valve.
	Incorrect ride height	Adjust ride height to proper setting. See Ride Height Adjustment in the Alignment & Adjustments Section of this publication.
Excessive driveline vibration	Incorrect ride height	Adjust ride height to proper setting. See Ride Height Adjustment in the Alignment & Adjustments Section of this publication.
	Broken main support member assembly	Replace main support member assembly
	Air spring(s) not inflated	Check air supply to air spring, repair as necessary.
Vehicle leans	Broken main support member assembly	Replace main support member assembly.
	Axle connection not torqued correctly	Perform U-bolt re-torque procedure. See Torque Specification Section of this publication.
	Worn pivot bushing	Replace pivot bushing.
	Air spring(s) not inflated	Check air supply to air spring, repair as necessary.
Suspension is noisy	Loose QUIK-ALIGN® attachment	Replace QUIK-ALIGN connection and check suspension alignment. Check frame hanger for wear around QUIK-ALIGN assembly and fasteners and replace as necessary.
	Loose U-bolts	Perform U-bolt re-torque procedure. See Torque Specification Section of this publication.
	Worn main support member isolator pads (if equipped)	Replace worn isolator pads (if equipped).
Irregular tire wear	Worn pivot bushing	Replace pivot bushing.
	Loose QUIK-ALIGN attachment	Replace QUIK-ALIGN connection and check suspension alignment. Check frame hanger for wear around QUIK-ALIGN assembly and fasteners and replace as necessary.
Main support member broken between U-bolts	Loose U-bolts	Replace main support member assembly and all mating parts.
QUIK-ALIGN or frame hanger worn	Loose fasteners and/or the re-use of old fasteners	Replace all worn parts and replace fasteners with new H-Coated fasteners.

# SECTION 11

## Torque Specifications



Hendrickson recommended torque values provided in Foot Pounds and in Newton Meter





## COMFORT AIR for Blue Bird Buses

## HENDRICKSON RECOMMENDED TORQUE SPECIFICATIONS

NO.	COMPONENT	Quantity	SIZE	*TORQUE VALUE	
				Foot Pounds	Nm
1.	QUIK-ALIGN Fasteners	2	1"-8 UNC	525-575	712-780
	 <b>WARNING</b> ENSURE THAT QUIK-ALIGN FASTENER TORQUE VALUES ARE SUSTAINED AS RECOMMENDED. FAILURE TO DO SO CAN CAUSE LOSS OF VEHICLE CONTROL RESULTING IN PERSONAL INJURY OR PROPERTY DAMAGE.				
2.	Main Support Member Spring Clip	2	7/8"-14 UNC	30-34	41-46
3.	U-bolts	4	7/8"-14 UNF	400-450	542-610
		21,000 / 23,000 lb. Capacity	4	3/4"-26 UNF	285-305
4.	Air Spring to Air Spring Bracket	2	1/2"	20-30	27-40
5.	Air Spring to Cross Channel	2	1/2"	20-30	27-40
6.	Shock Absorber to Upper Shock Bracket	2	1/2"-13 UNC	50-70	68-95
7.	Shock Absorber to Lower Shock Bracket	2	3/4"-10 UNC	160-180	217-245
8.	Cross Channel to Main Support Member	8	3/4"-10 UNC	260-320	355-435
9.	Cross Channel to HCV Linkage Bracket	2	1/4"-20 UNC	40-50 in. lbs.	5-6
10.	HCV Linkage Bracket to HCV Linkage	2	5/16"	80-90 in. lbs.	9-10
11.	HCV Linkage to Height Control Valve	2	5/16"	80-90 in. lbs.	9-10
12.	Height Control Valve to Frame	2	1/4"	40-50 in. lbs.	5-6
<b>NOTE:</b> * Torque values listed above apply only if Hendrickson supplied fasteners are used. If non Hendrickson fasteners are used, follow torque specification listed in vehicle manufacturer's service manual.					
 <b>WARNING</b> ALL COMFORT AIR FASTENERS FOR BLUE BIRD VEHICLES ARE H-COATED. METRIC BOLTS ARE CLASS 10.9 AND USE CLASS 10.0 LOCKNUTS. NON-METRIC FASTENERS ARE DETAILED AS SPECIFIED ABOVE. DO NOT ASSEMBLE WITHOUT THE PROPER FASTENERS. USE ONLY H-COATED FASTENERS TO SUSTAIN PROPER CLAMP FORCE. FAILURE TO DO SO CAN CAUSE LOSS OF VEHICLE CONTROL, PROPERTY DAMAGE OR PERSONAL INJURY.					



---

[www.hendrickson-intl.com](http://www.hendrickson-intl.com)



Truck Commercial Vehicle Systems  
800 South Frontage Road  
Woodridge, IL 60517-4904 USA

1.866.755.5968 (Toll-free U.S. and Canada)  
1.630.910.2800 (Outside U.S. and Canada)  
Fax 1.630.910.2899