

H TECHNICAL PROCEDURE

TRAILER SUSPENSION SYSTEMS STANDARD SERVICE WHEEL-END

SUBJECT: Hub Maintenance Procedures

LIT NO: L496

DATE: August 2020

REVISION: J

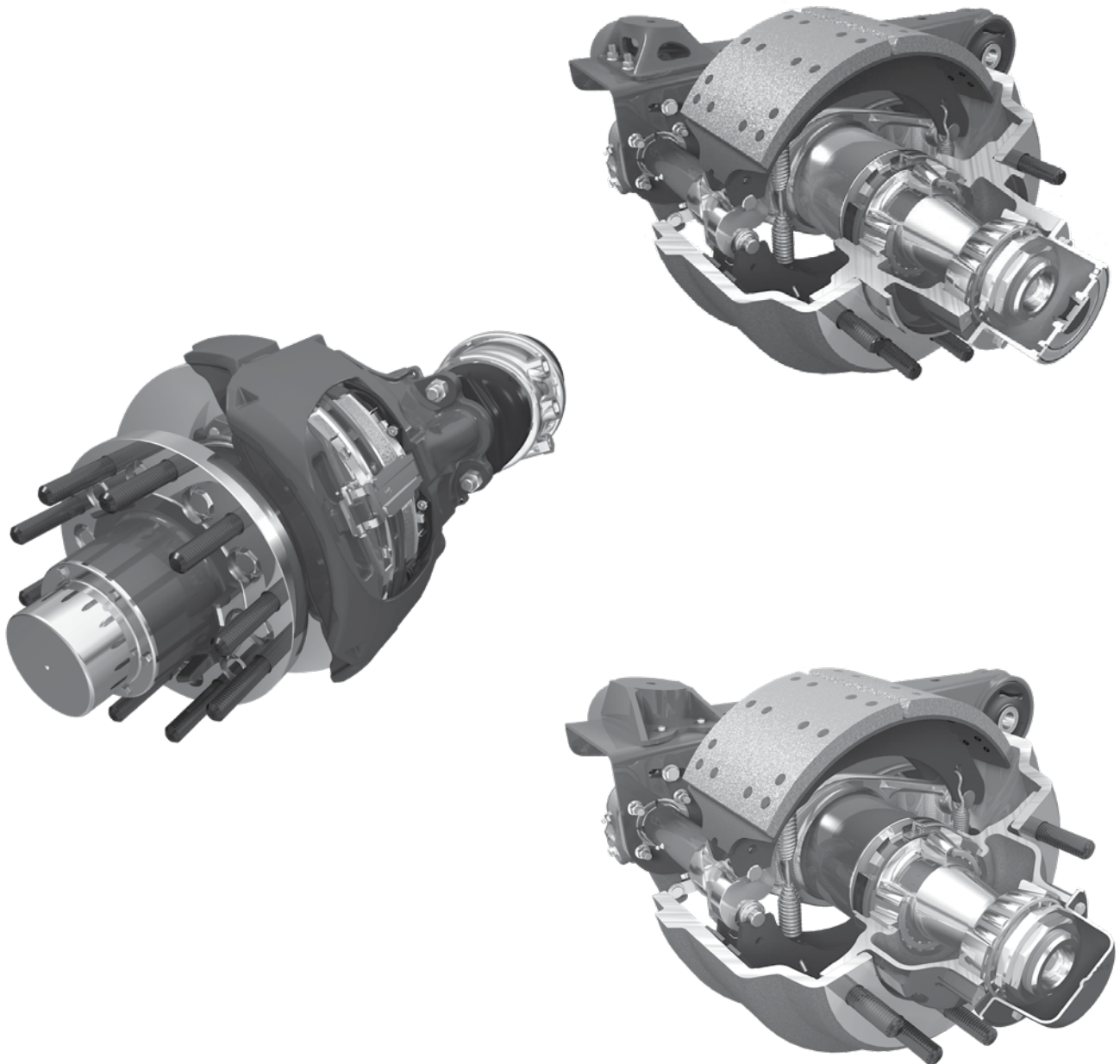



TABLE OF CONTENTS

Important Safety Notices 3

Conventions Applied in This Document..... 3

 Explanation of Signal Words 3

 Hyperlinks 3

 Contacting Hendrickson..... 3

 Relative Literature 4

 Preparing Trailer for Service 4

 Preparing Trailer for Maintenance Service 4

Introduction 5

 HLS® Hendrickson Long-Life System™ and HVS® Hendrickson Value System™ 6

 HXL Hendrickson Extended-life 6

 HXL3® Hendrickson Extended-Life 3-year System™ 6

 HXL5® Hendrickson Extended-Life 5-year System™ 6

 HXL7® Hendrickson Extended-Life 7-year System™ 6

 Tools Required 6

 ADB Hub and Rotor..... 6

Inspection 7

 Checking for Seal Leaks..... 7

 Checking for Smooth and Quiet Rotation 8

 Checking End Play..... 8

Removing and Installing Hub 10

 Hub Removal 10

 Spindle Preparation..... 11

 Prepare Hub for Re-Installation..... 12

 Assemble Hub 12

 Spindle-mounted Seal Assembly..... 13

 Hub-mounted Seal Assembly 13

 Hub and Outer Bearing Assembly - Semi Fluid Grease 14

 Hub and Outer Bearing Assembly - Oil Lubricant..... 14

 Hub and Outer Bearings Assembly - NLGI #2 Grease 14

 Standard Three- or Four-piece Spindle Nut Assembly 15

 Castle Spindle Nut Assembly 16

 Install Hubcap 17

 Hub Lubrication After Assembly, Oil Only 18

 Adding Oil Lubricant..... 18

 NLGI #2 Grease Lubricant 19

 Completing Installation..... 19

Additional Information..... 19

 Hub Semi Fluid Grease Dam 19

 Making a Hub Semi Fluid Grease Dam 19

 Torque Values 19

 Wheel Stud Removal and Installation Procedure 19



IMPORTANT SAFETY NOTICES

Hendrickson literature number **T12007** *Technical Procedure General Safety Precautions and Information*, available at www.Hendrickson-intl.com/TrailerLit, includes important preparation, precautionary and safety information pertaining to the procedures included in this document.

To help prevent personal injury and equipment damage; warnings, cautions and other relative statements included in Hendrickson literature number **T12007** are to be read carefully and applied during the performance of the procedures included in this document.

Improper maintenance, service or repair can cause damage to the vehicle and other property, personal injury, unsafe operating conditions and potentially void the manufacturer's warranty.

CONVENTIONS APPLIED IN THIS DOCUMENT

Various techniques are used in this document to convey important information, express safety issues, provide methods for **CONTACTING HENDRICKSON** and how to identify and apply **HYPERLINKS**.

EXPLANATION OF SIGNAL WORDS

Hazard signal words (such as DANGER, WARNING or CAUTION) appear in various locations throughout this publication. Information accented by one of these signal words must be observed at all times. Additional notes are utilized to emphasize areas of procedural importance and provide suggestions for ease of repair. The following definitions comply with **ANSI Z535.6** and indicate the use of safety signal words as they appear throughout the publication.

▲DANGER Indicates a hazardous situation that, if not avoided, will result in death or serious injury.

▲WARNING Indicates a hazardous situation that, if not avoided, could result in death or serious injury.

▲CAUTION Indicates a hazardous situation that, if not avoided, could result in minor or moderate injury.

NOTICE Indicates information considered important, but not hazard-related (e.g. messages relating to property damage).

IMPORTANT: An operating procedure, practice or condition that is essential to emphasize.

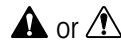

Safety Alert Symbol used to indicate a condition exists that, if not avoided, may result in personal injury or harm to individuals. It must be applied to DANGER, WARNING and CAUTION statements, which emphasize severity.

HYPERLINKS

Hyperlinks are identified by a dark grey line under the linked text. Internal links allow the reader to jump to a heading, step or page in this document. External links open the website or document referenced. While viewing electronically, activate the hyperlink by clicking on the underlined text.

CONTACTING HENDRICKSON

Contact Hendrickson Trailer Technical Services for technical assistance as needed. To do so, several options are available. Technical Services must be contacted before performing any warranty related service.

NOTE: DO NOT service a suspension or any component that is under warranty without first contacting Hendrickson Technical Services.

Prior to contacting Technical Services, it is best to have the following information about the vehicle and Hendrickson suspension available (all that apply):

- **Hendrickson suspension** information, (refer to [L977 Suspension and Axle Identification](#)) –
 - Suspension model number
 - Suspension serial number
 - Approximate number of suspension miles
- **Trailer information** (located on VIN plate) -
 - Type (van, reefer, flat bed, etc...)
 - Manufacturer
 - VIN (vehicle identification number)
 - In-service date¹
 - Fleet/owner name
 - Unit #

¹ If the in-service date is unknown or not available, the vehicle date of manufacture will be substituted.



- **Failure information**
 - Description of the system problem, the part number and/or the part description of the reported non-functioning part.
 - **Date of failure.**
 - Where applicable, **location of problem** on suspension / trailer (e.g., road side, front axle, rear axle, curb side rear, etc.).
- **Digital photos** of suspension and damaged areas.
- **Special application** approval documentation (if applicable).

PHONE

Contact **Hendrickson Trailer Technical Services** directly in the United States and Canada+ at **866-RIDEAIR (743-3247)**. From the menu, select:

- **Technical Services/Warranty** for technical information.
- Other selections include:
 - **Aftermarket Sales** for replacement parts information and ordering.
 - **Original Equipment Sales** for parts inquiries and ordering for trailer manufacturers.

EMAIL

HTTS@Hendrickson-intl.com

Contact Hendrickson for additional details regarding specifications, applications, capacities, and operation, service and maintenance instructions.

All applications must comply with applicable Hendrickson specifications and must be approved by the respective vehicle manufacturer with the vehicle in its original, as-built configuration.

RELATIVE LITERATURE

If you suspect your version of this or any other Hendrickson manual is not “up-to-date”, the most current version is free online at:

www.Hendrickson-intl.com/TrailerLit

Available Hendrickson documentation can be viewed or downloaded from this site.

All Hendrickson online documentation is in PDF format that requires PDF reader software to open. A free application is downloadable from Adobe at <http://get.adobe.com/reader/>.

Other relative literature may include:

LIT NO.	DESCRIPTION
L583	<i>Comprehensive Warranty Statement</i>
L578	<i>Suspension Preventive Maintenance Guide</i>
L974	<i>Drum Brake Maintenance Procedures</i> , heading “RETRACTING THE BRAKE SHOES OR SLACK ADJUSTER CONTROL ARM(S)”
T71004	<i>Hub and Rotor Assembly and Caliper Mounting Procedures</i>
T82006	<i>Stud Replacement Procedure</i>

Table 1: Relative wheel-end literature

PREPARING TRAILER FOR SERVICE

Information for trailer preparation, safety and precautionary statements, refer to Hendrickson literature number T12007, available at www.Hendrickson-intl.com/TrailerLit.

NOTE: DO NOT service a suspension or any components that is under warranty without first contacting Hendrickson Technical Services. Refer to CONTACTING HENDRICKSON for details.

⚠WARNING Do not work under a trailer supported only by jacks. Jacks can slip or fall over, resulting in serious personal injury. Always use safety stands to support a raised trailer.

Hendrickson reserves the right to make changes and improvements to its products and publications at any time. Consult the Hendrickson website

www.Hendrickson-intl.com/TrailerLit

for the latest version of this manual.

PREPARING TRAILER FOR MAINTENANCE SERVICE

Information for trailer preparation, safety and precautionary statements, refer to Hendrickson literature number T12007, available at www.Hendrickson-intl.com/TrailerLit.

NOTE: DO NOT service a suspension or any components that is under warranty without first contacting Hendrickson Technical Services. Refer to CONTACTING HENDRICKSON for details.

⚠WARNING **DO NOT** work under a trailer supported only by jacks. Jacks can slip or fall over, resulting in serious personal injury. Always use safety stands to support a raised trailer.



STANDARD HUB MAINTENANCE PROCEDURES

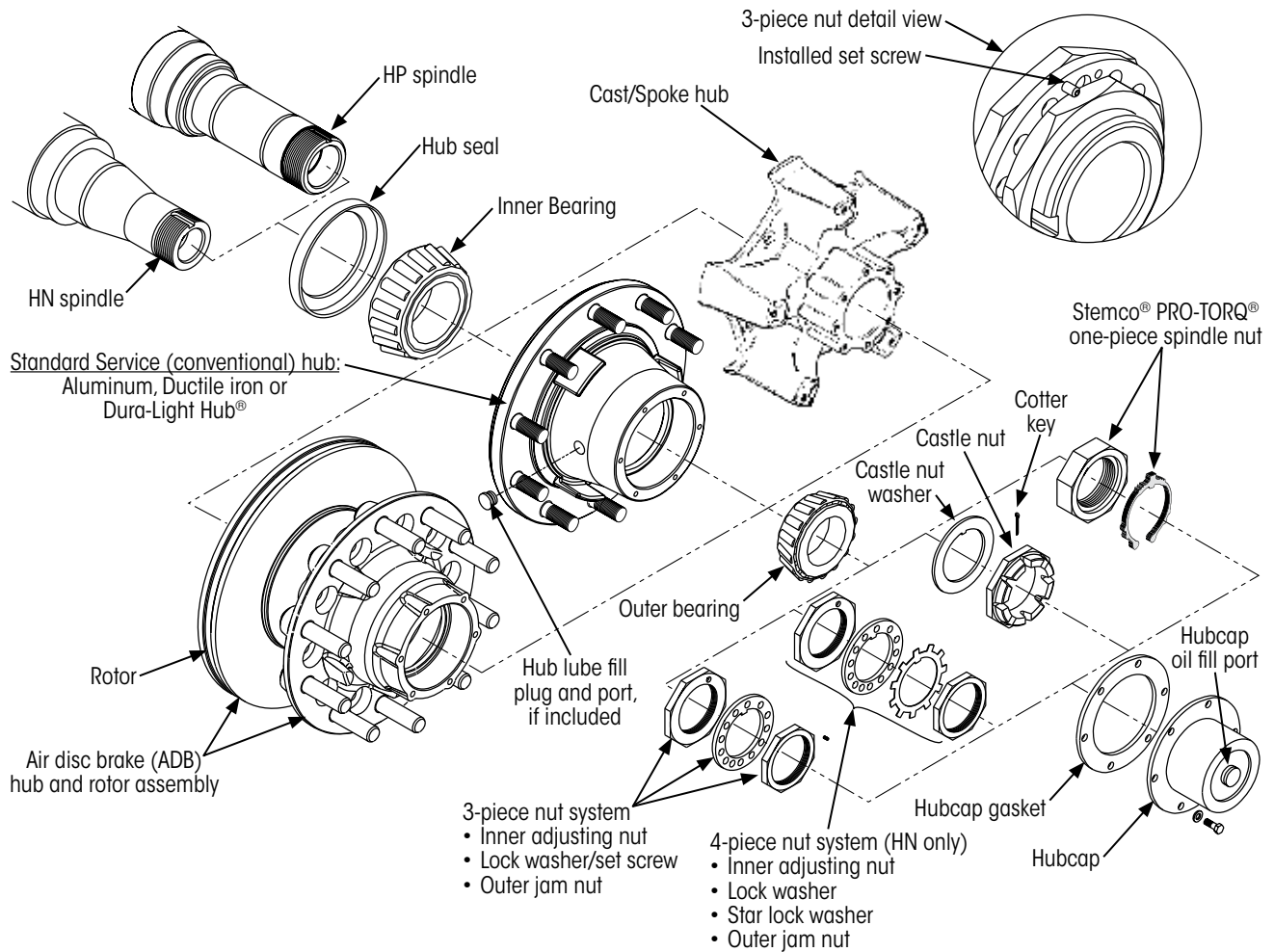

Figure 1: Hendrickson's Standard Service wheel-end parts identification

INTRODUCTION

Hendrickson's **Standard Service Hub Assembly** (Figure 1) is a basic hub that applies conventional assembly processes defined in this document. For this process, components (hub, seal, inner and outer bearings) are specified and individually assembled, one at a time, onto the spindle (or into the hub bore). The Standard Service wheel-end includes components available from Hendrickson, but specified by the customer. Whereas Hendrickson's Extended Life wheel-ends are Hendrickson specified by RTR (Ready-to-Roll) model and factory installed at Hendrickson. Each are delivered as complete subassemblies on a dressed axle.

The standard service hub (Figure 1) may be ductile iron, aluminum or Dura-Light Hub® and vendors include ConMet, Walther EMC, KIC or Webb. Spindle types include HN (tapered) or HP (parallel). In these procedures, all hubs are considered conventional hubs that are maintained and assembled similarly.

All components are field serviceable, however, no service of any kind should be attempted without first **CONTACTING HENDRICKSON**. Recommendations for preventative maintenance practices are listed in Hendrickson literature number L578 *Suspension Preventive Maintenance Guide*.

NOTICE

Accessory-type hubcaps, such as the chrome "top hat" style hubcap, increase wheel-end temperatures during operation and are not recommended for use on Hendrickson Standard or Extended Service wheel-ends.

NOTE: Hendrickson recommends HP spindle type for offset super single tire applications. Refer to Hendrickson literature number L846 *Wide Base Tire Configurations* for more details. The HN spindle design is not approved for use with any single offset wheel.



Other types of wheel-end assemblies can be found on Hendrickson suspensions for both drum and air disc brake (ADB) systems.

HLS® HENDRICKSON LONG-LIFE SYSTEM™ AND HVS® HENDRICKSON VALUE SYSTEM™

For service information on these wheel-end types, refer to Hendrickson literature number T72004 HLS® *Wheel-end Maintenance Procedures* or T72005 HVS® *Wheel-end Maintenance Procedures*.

HXL HENDRICKSON EXTENDED-LIFE

Hendrickson Extended-Life wheel-ends offer premium performance on Hendrickson dressed axles. Hendrickson selects premium components which are factory assembled in a controlled environment; allowing for an extended-service warranty beyond that of a standard service wheel-end.

HXL3® HENDRICKSON EXTENDED-LIFE 3-YEAR SYSTEM™

HXL3 wheel-ends come with oil bath lubrication (75W-90 synthetic gear lubricant or SAE 80W-90 gear lubricant) and a three-year limited warranty. Spindle types include HN (tapered) or HP (parallel) with Hendrickson's PRECISION240® or PRECISION320® Nut System. Service and other applicable information can be found or is referenced in Hendrickson literature number T72006 *Wheel-end Maintenance Procedures*.

HXL5® HENDRICKSON EXTENDED-LIFE 5-YEAR SYSTEM™

HXL5 wheel-ends feature synthetic semi fluid grease (Delo® Syn-Grease™ SFE EP). Spindle types include HN (tapered) or HP (parallel) with Hendrickson's PRECISION240 or PRECISION320 Nut System. Service and other applicable information can be found or is referenced in Hendrickson literature number T72007 *Wheel-end Maintenance Procedures*.

HXL7® HENDRICKSON EXTENDED-LIFE 7-YEAR SYSTEM™

HXL7 wheel-ends feature ductile iron, aluminum or Dura-Light Hub®, synthetic semi-fluid grease (Delo® Syn-Grease™ SFE EP) and HP (parallel) spindle with Hendrickson's PRECISION320 Nut System. Service and other applicable information can be found or is referenced in Hendrickson literature number T72002 *Wheel-end Maintenance Procedures*.

TOOLS REQUIRED

The following tools may be required during the performance of some maintenance procedures:

TOOL		WHERE USED
Dial Indicator, with mounting stand (resolution to 0.0001", 0.0254 mm)		End-play measurement. Refer to Figure 4 on page 9.
Hub-mounted seal driver (Figure 13)		Available from seal manufacturer
Spindle-mounted seal driver (Figure 12)		Available from seal manufacturer
Torque Wrench (10 - 400 ft.lbs. or 13 - 542 Nm)		Used to tighten various plugs, screws and nuts, listed in this table, to the specified torque.
1/2 inch socket		Hubcap fasteners
1/4 or 5/16 inch hex key		Lube fill port plug, oil filled hub
HUB SEMI FLUID GREASE DAM on page 19		HUB AND OUTER BEARING ASSEMBLY - SEMI FLUID GREASE on page 14
HN spindle	For three- or four-piece nut system ¹	
	3 7/8 inch socket	Inner Adjusting nut
	3 1/4 inch socket	Outer jam nut
	5/64 inch hex key	Set screw
HP spindle	For three-piece nut system ¹	
	4 7/8 inch socket	Inner Adjusting nut
	4 3/8 inch socket	Outer jam nut
	5/64 inch hex key	Set screw
¹ All sockets have 8 points.		

Table 2: List of required tools

IMPORTANT: Torque (Table 4 on page 19) cannot be properly applied with an ordinary wrench. **A calibrated torque wrench must be used to tighten fasteners** to specified values.

ADB HUB AND ROTOR

For air disc brake (ADB) systems, the caliper must be removed before removing the hub and rotor assembly. ADB rotor and caliper mounting is defined in Hendrickson literature number T71004 *Hub and Rotor Assembly and Caliper Mounting Procedures*. Original mounting hardware must be discarded, once removed, and replaced with new hardware during reassembly.

Procedures for service and repair of Hendrickson's MAXX22T™ ADB can be found in Hendrickson literature number T72009. For component replacement and repair of ADB systems and rotors manufactured by other vendors, links to Bendix, ConMet, Haldex and Wabco literature is available at

www.hendrickson-intl.com/TrailerLit.

INSPECTION

As a general practice, the hub assembly should be checked for seal leaks and smooth rotation.

⚠WARNING Prior to performing inspection procedures, ensure conditions are safe by following steps in section PREPARING TRAILER FOR SERVICE.

NOTE: Recommended inspection intervals are based on an average trailer usage of 100,000 miles (160,000 km) per year. Higher usage would require more frequent inspections. Conversely, lower usage would require less inspection. Refer to Hendrickson literature number L578 Suspension Preventive Maintenance Guide for more details.

Inspections should be performed:

- Daily pre-operation check. This would include a general walk around to check for signs of obvious damage, wear or other abnormalities.
- Every month, visually inspect back of hub and hubcap gasket for leakage. Refer to the section titled CHECKING FOR SEAL LEAKS for complete inspection details.
- Every three to four months:
 - Perform monthly inspection.
 - Check for smooth rotation.
 - » Refer to the section titled HYPERLINKS for details.
 - » If hub feels rough, sounds noisy or does not rotate freely; CHECKING END PLAY and/or make necessary repairs.
- During brake service and relining when the wheel-end will be dismantled enough to easily make these inspections. In addition to the inspection at brake service, always maintain current shop preventive maintenance and pre-trip inspection practices.

CHECKING FOR SEAL LEAKS

The hub assembly is filled with the specified lubricant at the factory during the assembly process. On the inboard side, lubricant is contained in the hub by the hub seal where leakage can occur (Figure 1 on page 5).

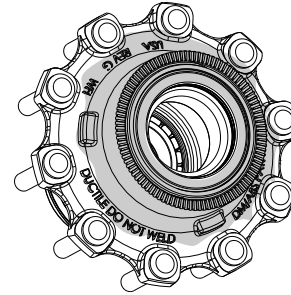

Figure 2: Check back side of hub for seal leak

To check for leaks, look at the inboard side of the hub, (Figure 2). A small amount of lubricant may be visible at the hub seal. **This is a normal occurrence and does not necessarily indicate a seal leak.**

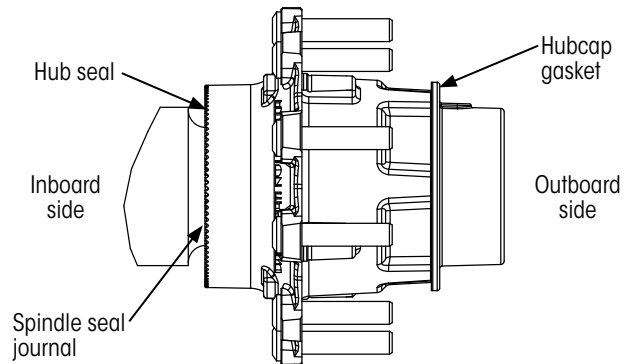

Figure 3: Areas where leaks may occur

A small amount of lubricant may also appear at the spindle bearing shoulder to hub joint (Figure 3). **This is also normal and does not necessarily indicate a seal leak.** It should be wiped clean to minimize any accumulation of dirt.

NOTICE Pressure or steam washing should be avoided in this area as water could be forced past the seal and degrade lubricant performance and corrode bearings.

If the hub seal is leaking, a large quantity of lubricant will be present. Oil will be spattered on rim and tires. If this is the case, the seal and other components may need to be replaced. Take corrective action as needed.

CHECKING FOR SMOOTH ROTATION

Many factors can effect smoothness of rotation. Primary causes include:

- Bearing wear
- Damaged hub seal
- Moisture
- Debris

NOTE: A reasonable assessment can be performed without removing tires and rims. However, this procedure is best performed with hub only as shown in [Figure 5](#).

1. **Ensure** trailer is secure per [PREPARING TRAILER FOR SERVICE](#) on [page 4](#).
2. **Disengage** brakes and, if brake shoes, remove brake drum (recommended).
3. While maintaining physical contact, **slowly rotate** hub in both directions at least five revolutions.
4. **During rotation**, ensure smooth and quiet rotation. Bearings should move smoothly. Feel for any resistance in movement. Any debris in bearings should be felt as it moves over rollers in bearings.

IMPORTANT: If bearings feel rough, sound noisy or DO NOT rotate freely, DO NOT place the suspension back into service. Refer to [CONTACTING HENDRICKSON Technical Services](#) for guidance.

- A. If rotation feels normal, return to previous procedure or reassemble and restore trailer to normal operation.
- B. If rotation sounds noisy, check end play.
- C. If rotation feels rough or does not rotate freely, refer to [CONTACTING HENDRICKSON](#) on [page 3](#).

CHECKING END PLAY

NOTE: If extended service wheel-end (HXL), refer to applicable literature and [CONTACTING HENDRICKSON](#) on [page 3](#) before continuing.

This procedure should be performed:

- After [CONTACTING HENDRICKSON](#) Technical Services for guidance relative to suspected wheel end play movement, before removing the hubcap.
- **After** installing hub and when instructed by spindle nut installation procedure.

1. If not already done so:
 - A. **Perform** [PREPARING TRAILER FOR SERVICE](#) on [page 4](#).
 - B. **Remove** wheel (tires and rims).
 - C. **Disengage** brakes.
 - D. If drum brake, **remove** drum (recommended). If ADB, **remove** brake pads per manufacturer's recommended procedures.
 - E. If oil lubricated, **drain** oil from wheel-end (do not reuse).
 - F. **Remove** hubcap and discard gasket.

IMPORTANT: End play can be checked with brake drum installed or removed (preferred). If installed, **ensure all brake drum wheel fasteners are installed and tightened to manufacturers specifications** before checking end play.

2. **Ensure** hub hubcap mounting surface and end of spindle are **clean and totally free of any burrs or debris**.
3. **Rotate** hub **at least 5 revolutions** to ensure bearings are fully seated.

NOTE: The hub **MUST** be rotated before performing end play measurement. Rotation works the rollers into their fully seated positions against the bearing cone shoulder. **Failure to rotate hub could result in a false end play reading.**

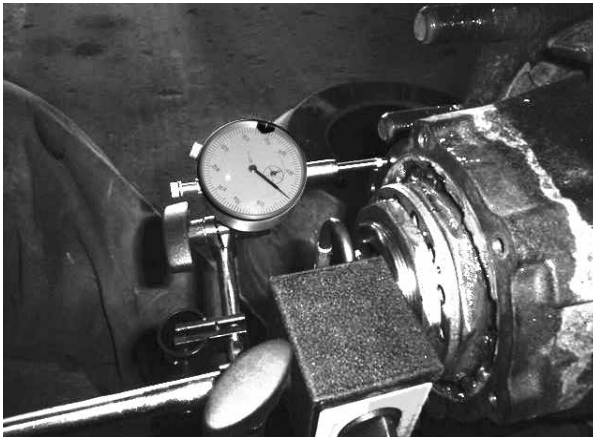

Figure 4: Checking end play

4. **Attach dial indicator** (Table 2) with magnetic base to flat surface at end of spindle (Figure 4).
5. **Position dial indicator** so its pointer line of action is parallel to spindle axis and touches the hubcap mounting surface on the hub. Ensure the plunger contacts the hub in an area that is smooth and fully machined. Any regions with scratches, gouges or non-cleanup should be avoided.
6. **Check indicator** for free movement in both directions. Lightly **push and pull** on indicator arm to verify plunger is free to move at least 0.005" in each direction. If indicator bottoms out, readjust until it is free to move 0.005" in both directions.

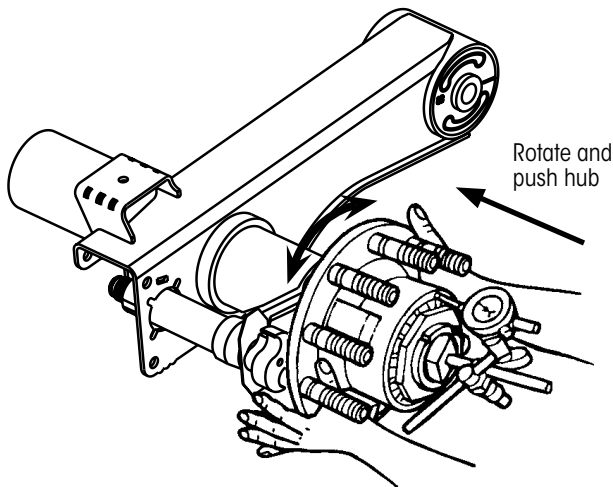

Figure 5: Checking inward end-play

7. **Zero indicator.**
8. **Grasp hub flange** as shown in Figure 5, and **push** the hub inward **while rotating** the hub slightly in both directions (between two hub cap fastener holes) until the dial indicator reading remains constant. **Record reading.**

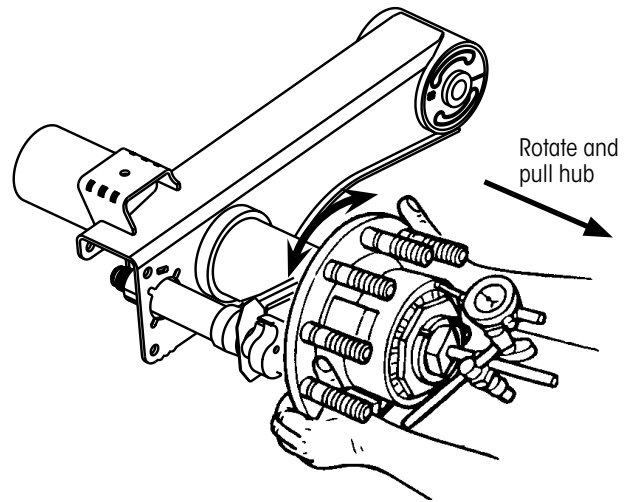

Figure 6: Checking outward end-play

9. While still grasping hub (Figure 6), **pull** hub outward **while rotating** hub slightly in both directions (between two hub cap fastener holes) until dial indicator reading remains constant. **Record reading.**
10. End play is the total movement of the indicator. **Calculate** difference between recorded values of Step 8 and Step 9 to determine end play, **record** value.

IMPORTANT: End play should be between 0.001" (0.0254 mm) and 0.005" (0.127 mm). If subsequent readings are necessary, the hub must be rotated at least 5 revolutions to reseal the bearings (refer to Step 3).

- A. **If checking after spindle nut installation**, return to:

SPINDLE NUT SYSTEM	RETURN TO
STANDARD THREE- OR FOUR-PIECE SPINDLE NUT ASSEMBLY	Step 10 on page 15
CASTLE SPINDLE NUT ASSEMBLY	Step 7 on page 17
Stemco PRO-TORQ® nut	Refer to manufacturer's manual for installation procedures.

- B. If end play is **within specification**, no bearing adjustment is necessary. Continue to next step.
- C. If end play is **greater than 0.005" (0.127 mm)**, tighten spindle nut (**STANDARD THREE- OR FOUR-PIECE SPINDLE NUT ASSEMBLY** on page 15) or refer to **CONTACTING HENDRICKSON Technical Services.**

IMPORTANT: If end play is not within specifications, **DO NOT** place suspension back into service without correcting the problem.

11. Check to **ensure**, for 3-piece nut system (Figure 15 on page 15):
 - A. Inner adjusting nut is secure.
 - B. Lock washer and tang are properly seated.
 - C. Outer jam nut and retaining set screw are securely in place.
12. If not already done so, perform CHECKING FOR SEAL LEAKS on page 7.
13. Go to INSTALL HUBCAP on page 17.

REMOVING AND INSTALLING HUB

WARNING Prior to performing maintenance procedures, ensure conditions are safe. Refer to PREPARING TRAILER FOR SERVICE on page 4.

NOTE: In order to maintain warranty status, CONTACTING HENDRICKSON is recommended before removing the hubcap and disturbing the spindle nut.

Removal of hubcap hex head screws and/or hubcap is allowed when:

- Attaching hubometer bracket.
- During TIREMAAX[®] installation.

NOTICE The old gasket must be discarded and replaced with new. Tighten fasteners to 15±3 ft. lbs. (21±3 Nm) of torque.

HUB REMOVAL

Use the following procedure to remove hub assembly:

1. **Remove** tire / wheel assembly.
2. **Disengage** brakes and:
 - If drum brake, **remove** brake drum.
 - If ADB equipped, **remove** the caliper.
3. **If oil, drain** the oil from the hub.
4. **Remove** hubcap hex head screws and hubcap.
5. **Remove** and **discard** gasket.

REMOVE SPINDLE NUT

One of four spindle nut systems (Figure 7 through Figure 8) is used to secure a standard service hub to the spindle/axle:

- Standard three- or four-piece spindle nut
- Castle spindle nut (cross drilled HP spindles only)
- Stemco PRO-TORQ[®] nut system

Each of these spindle nut systems has a different locking mechanism which must be disengaged before spindle nut(s) can be removed.

1. **Disengage** spindle nut locking mechanism as follows:

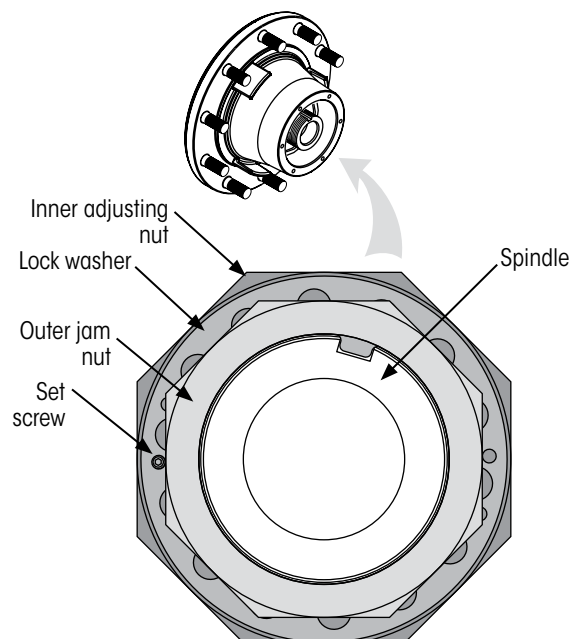

Figure 7: Three-piece nut system components

- A. **Standard** three-or four-piece nut (Figure 7) -
 - i. If three-piece, using a ⁵/₆₄ inch hex key, **remove** set screw from interlock washer.
 - ii. If four-piece, lift tabs from the flats on the outer nut. See Figure 18 on page 16.
 - iii. **Remove** spindle nuts and lock washer.

NOTICE DO NOT attempt to rotate the outer nut without first unlocking the nut system. Doing so can damage spindle threads and compromise the axle. Remove the lock washer before rotating the inner nut.

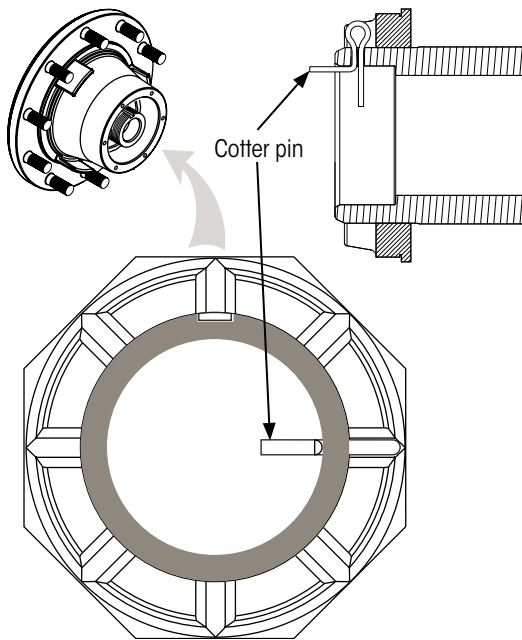

Figure 8: Castle spindle nut system (HP spindles only)

- B. **Castle** spindle nut system, applies to cross drilled HP spindle only (Figure 8) -
 - i. **Remove** and discard cotter pin.
 - ii. **Remove** spindle nut(s) and washer or lock washer (if equipped).

REMOVE HUB

After the spindle nut is removed, the hub is free to be gently removed from the spindle while avoiding damage to spindle and spindle threads.

CAUTION For safety reasons and to prevent damage to hub and spindle, lifting equipment may be required to lift and support the hub as it is being removed from the spindle.

NOTICE Any damage to spindle or hub machined surfaces can affect wheel-end performance.

1. **Carefully pull** hub assembly slightly toward spindle end. A short quick motion should allow outer bearing to exit the hub. Be prepared to catch outer bearing if it slides off the end of the spindle. Otherwise, simply remove it.
2. **Remove** hub from spindle. The inner bearing is held in hub by the hub seal and should come off with hub.

3. **Remove and discard** hub seal:
 - A. **If the seal is in the hub** - a pry bar can be used to carefully remove seal from hub bore. Damage to hub and hub surfaces must be avoided.
 - B. **If the seal is on the spindle** - Using a brass, leather or other soft-faced mallet, drive seal off spindle by carefully striking seal from the back side.
4. **Remove, clean and inspect** inner bearing. Replace if needed.

SPINDLE PREPARATION

Before installing hub, follow this procedure to ensure spindle machined surfaces are clean and undamaged.

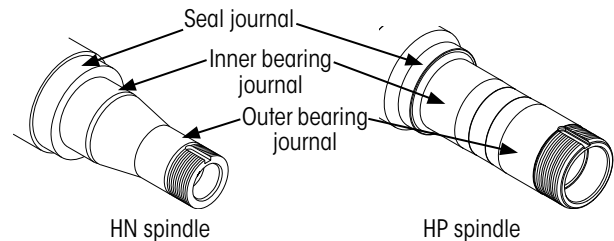

Figure 9: Spindle seal & bearing journals

1. **Remove** old lubricant and thoroughly clean spindle.
2. **Inspect** machined spindle journals (Figure 9) for nicks, scratches, burrs or marks. If needed, use crocus cloth or emery cloth to repair any damaged areas.
3. **Thoroughly clean** spindle threads and keyway with a wire brush to avoid false bearing adjustments and to avoid introduction of contaminants into the lubricant cavity.
4. **Thoroughly clean** spindle machined surfaces of rust, dirt, grease or any contaminants that could damage the hub seal and cause it to leak.
5. **Lubricate** spindle bearing surfaces with the same lubricant used to fill the hub.

NOTICE To minimize fretting and damage to wheel-end, lubricate all components and applicable surfaces using the same lubricant.

PREPARE HUB FOR RE-INSTALLATION

The hub and bearings should be cleaned and inspected prior to installation.

1. **Thoroughly clean** the hub bore of any dirt, grease, rust or any other substance that may be present.
2. **Inspect** hub seal bore for roughness. If needed, use emery cloth to remove any burrs or old bore sealant and wipe hub clean.
3. **Remove** all sharp edges, nicks and burrs from seal bore, hubcap bore and hubcap mounting surface of the hub.
4. **Ensure** hubcap mounting surface is smooth and free of debris.
5. Using the same lubricant used to fill the hub and **lubricate** hub seal and bearing journals.

IMPORTANT: DO NOT lubricate if Stemco seal.

6. If filling with NLGI #2 grease, prior to assembly:

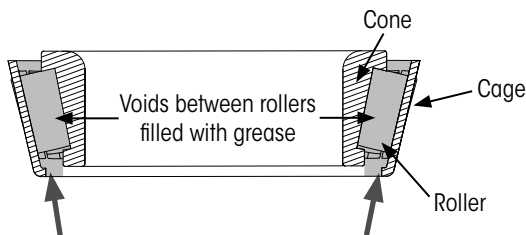

Pack from small end until grease purges out the big end

Figure 10: If packing bearing with NLGI #2 grease

- A. **Pack** both inner and outer bearings with grease (Figure 10).

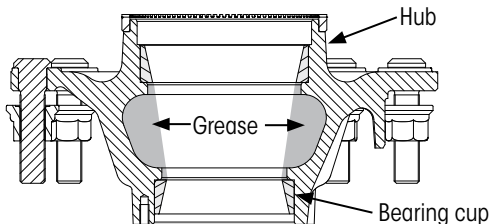

Figure 11: Pack hub inner cavity

- B. **Pack** hub inner chamber, full circle (Figure 11), with grease to slightly above the level of the bearing cup.

ASSEMBLE HUB

This procedure assumes field installation of the hub. Hub assembly includes:

- Hub Seal and inner bearing assembly:
 - SPINDLE-MOUNTED SEAL ASSEMBLY
 - HUB-MOUNTED SEAL ASSEMBLY
- HUB AND OUTER BEARING ASSEMBLY - SEMI FLUID GREASE on page 14
- HUB AND OUTER BEARING ASSEMBLY - OIL LUBRICANT on page 14
- HUB AND OUTER BEARINGS ASSEMBLY - NLGI #2 GREASE on page 14

NOTICE

The HUB SEAL CAN BE DAMAGED or prematurely fail if:

- Hub seal is improperly installed.
- Hub seal is rammed into the spindle bearing shoulder.
- Hub is not kept supported and aligned with spindle until the outer bearing and axle nut are installed.
- Lubricant types are mixed during hub assembly.

NOTICE

To minimize fretting and damage to wheel-end, lubricate all components and applicable surfaces using the same lubricant.

CAUTION

For safety reasons, to prevent injury and damage to the hub and spindle, lifting equipment may be required to lift and support the hub as it is being installed onto the spindle.

SPINDLE-MOUNTED SEAL ASSEMBLY

This type of seal is mounted on the spindle before installing the hub. The replacement seal should be same brand and type as originally installed by the OEM. A recommended installation tool (Figure 12), with instructions, is available from the seal manufacturer.

1. **Lubricate seal** according to seal manufacturer's recommendations.
2. Following manufacturer's instructions, **place** the seal on the spindle (Figure 12). **Ensure** the seal is correctly oriented with "air side" facing inboard and "oil side" facing outboard.

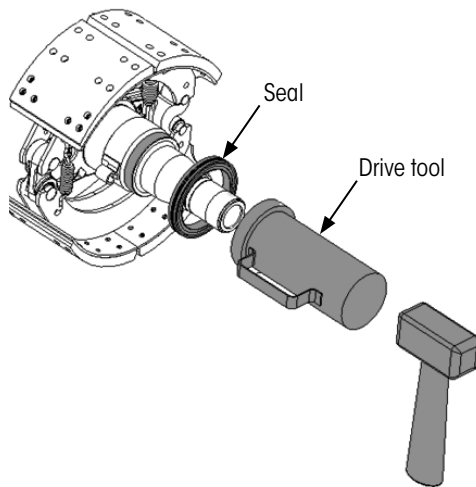

Figure 12: Spindle-mounted seal installation

3. **Place** installation tool over the spindle and drive seal until it is flush with the bearing shoulder.
4. **Rotate** installation tool and apply several light blows to ensure seal is properly seated against bearing shoulder.
5. Using the specified lubricant, **lubricate** inner bearing journal and cone.
6. **Install** the pre-lubricated inner bearing onto spindle. If it becomes misaligned, use a small hammer to tap lightly on the unmachined part of the axle tube. This will ease installation by creating vibrations which will help realign the bearing on the spindle.

NOTICE NEVER hit a bearing with a hammer

HUB-MOUNTED SEAL ASSEMBLY

This type of seal is mounted directly to the hub inner bore before installing hub. The replacement seal should be same brand and type as originally installed by the OEM. A hub-mount seal installation tool, with instructions, is available from seal manufacturer.

1. **Apply lubricant** to spindle, bearing journals.

NOTE: The hub was pre-lubricated during PREPARE HUB FOR RE-INSTALLATION on page 12.

2. **Install** pre-lubricated inner bearing into hub against inner bearing cup. **Ensure** it is properly seated in the cup.

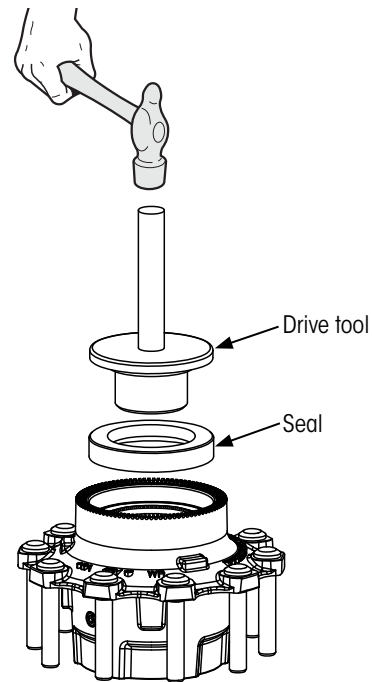

Figure 13: Hub-mounted seal installation

NOTE: A hub seal driver (Figure 13) is recommended and can be obtained from seal manufacturer.

3. **Lubricate seal** according to the seal manufacturer's recommendations.
4. **Place** seal onto the drive tool (Figure 13) for installation into the hub according to seal manufacturer's instructions.
 - A. **Align** seal tool with hub seal bore.
 - B. **Drive** seal until it bottoms out in the hub seal bore.
 - C. **Rotate** installation tool and apply several light blows to **ensure** seal is properly seated.
 - D. **Check** inner bearing to ensure it rotates freely.

HUB AND OUTER BEARING ASSEMBLY - SEMI FLUID GREASE

With seal and inner bearing in place; the hub, semi fluid grease and the outer bearing can now be installed; in that order.

NOTE: Refer to MAKING A HUB SEMI FLUID GREASE DAM on page 19 for instructions on making the dam.

NOTICE When completed, the hub should be filled to 50% of hub cavity (to 3 & 9 o'clock position when viewing from end of spindle). Any air bubbles or aeration of grease may result in insufficient grease quantity, bearing spalling and wheel-end damage.

1. Taking care not to damage the seal, **gently slide** the hub onto spindle until the seal is against the spindle seal journal (Figure 9).
2. **Support** and do not allow hub to move off center while completing the assembly.

NOTICE If the hub is not properly supported, the seal could be damaged.

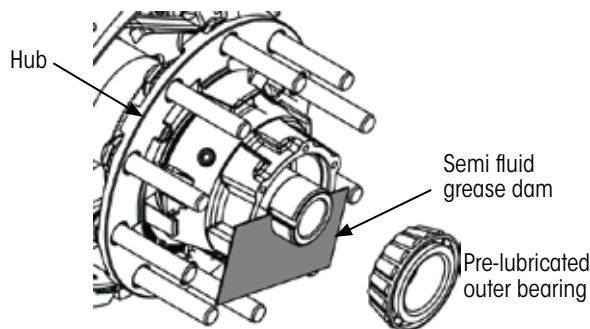

Figure 14: Semi fluid grease dam application

3. With the hub supported in position as shown in Figure 14, **place and hold** the semi fluid grease dam so it covers the lower half the hub opening.
4. **Fill** hub cavity to the top of the dam (3 & 9 o'clock position when viewing from end of spindle) with semi fluid grease.
5. **Pre-lube** outer bearing with a coating of semi fluid grease.
6. **Place** grease coated outer bearing over the spindle and against the semi fluid grease dam (Figure 14).
7. **Slide** the dam out as the bearing is inserted into the hub outer bearing cup.
8. **Clean** as needed to remove grease from unwanted areas.

NOTE: While sliding hub onto spindle, grease is collected at the spindle seal journal inboard of the hub (Figure 3 on page 7). This may be later interpreted as a grease leak and should be cleaned.

9. Continue with STANDARD THREE- OR FOUR-PIECE SPINDLE NUT ASSEMBLY on page 15.

HUB AND OUTER BEARING ASSEMBLY - OIL LUBRICANT

With seals in place, the hub and outer bearing can now be installed onto spindle.

1. **Gently slide** hub onto spindle, taking care not to damage the seal.
2. **Support** and do not allow hub to move off center while completing the assembly.
3. **Lubricate** outer bearing.
4. **Place** outer bearing over the spindle and into the hub outer bearing cup.

NOTE: While sliding hub onto spindle, oil is collected at the spindle bearing shoulder inboard of the hub (Figure 3 on page 7).

5. **Clean** spindle and hub area as needed.
6. Continue with STANDARD THREE- OR FOUR-PIECE SPINDLE NUT ASSEMBLY on page 15.

HUB AND OUTER BEARINGS ASSEMBLY - NLGI #2 GREASE

With seals in place, the hub, grease and outer bearing can now be assembled onto the spindle, in that order.

1. **Gently slide** the pre-lubricated hub (packed, Figure 11 on page 12) onto spindle, taking care not to damage the seal.
2. **Support** and do not allow hub to move off center while completing the assembly.
3. **Place** pre-lubricated (packed, Figure 10 on page 12) outer bearing over the spindle and into the hub outer bearing cup.
4. **Clean** spindle and hub area as needed.

NOTE: While sliding hub onto spindle, grease is collected at the spindle bearing shoulder inboard of the hub (Figure 3 on page 7). This may be later interpreted as a grease leak and should be cleaned.

5. Continue with STANDARD THREE- OR FOUR-PIECE SPINDLE NUT ASSEMBLY.



STANDARD THREE- OR FOUR-PIECE SPINDLE NUT ASSEMBLY

WARNING FAILURE TO FOLLOW THESE INSTRUCTIONS COULD CAUSE WHEEL TO COME OFF AND CAUSE BODILY INJURY.

OVER-TIGHTENING NUT COULD CAUSE BEARINGS TO RUN HOT AND BE DAMAGED.

NOTE: For other types of spindle nuts, refer to the manufacturer's literature for installation procedures.

The three-piece spindle nut system (Figure 15 on page 15) includes an inner adjusting nut, lock washer, inner jam nut and set screw.

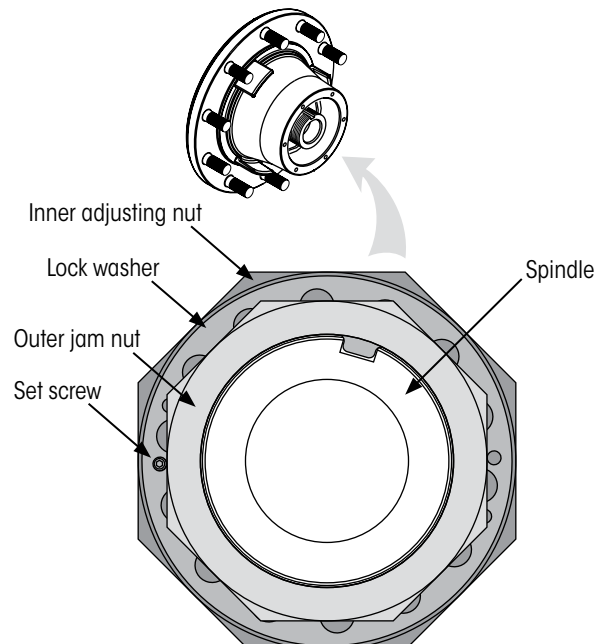

Figure 15: Three-piece nut system components

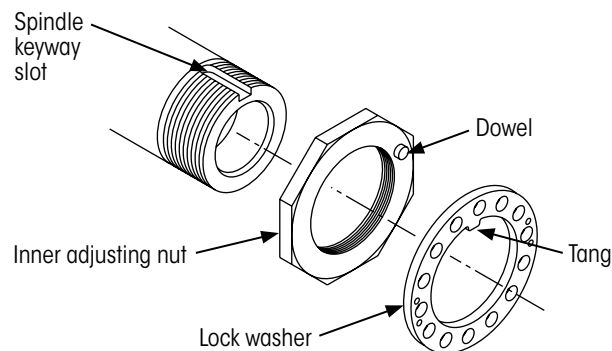

Figure 16: Adjusting nut and lock washer installation

1. Install inner adjusting nut (Figure 16) on spindle, dowel side out, and tighten to 200 ft. lbs. (271 Nm) of torque while rotating wheel.
2. Back off inner adjusting nut one full turn.
3. Rotate wheel at least 5 revolutions to seat bearings.
4. Tighten inner adjusting nut to 50 ft. lbs. (68 Nm) of torque while rotating hub.
5. Back off the inner adjusting nut ¼ turn.

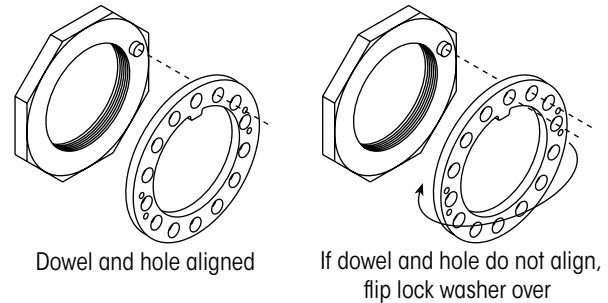

Figure 17: Align adjusting nut dowel with hole in lock washer

6. Install lock washer (Figure 16). Ensure lock washer tang fits in the spindle keyway slot and inner adjusting nut dowel fits in one of the holes in the lock washer. If this alignment cannot be achieved, remove the lock washer, flip it over and reinstall it on spindle (Figure 17).

NOTICE DO NOT tighten inner adjusting nut for dowel pin alignment. This can excessively pre-load bearings, resulting in premature failure.

If the dowel and hole still don't line up, loosen the inner adjusting nut slightly until alignment occurs.

7. If 4-piece nut system, install star washer over lock washer as shown in Figure 1 on page 5.
8. Install outer jam nut (Figure 15).
9. Tighten outer jam nut to:

SPINDLE	TORQUE
HN	315 ft. lbs. (427 Nm)
HP	385 ft. lbs. (522 Nm)

Table 3: Outer jam nut torque values.

10. Perform CHECKING END PLAY on page 8 and return to next step when procedure is complete.

IMPORTANT: End play must be between 0.001" (0.0254 mm) and 0.005" (0.127 mm).

- A. If end play is **within specifications**, go to next step to install set screw.
- B. **If excessive end play** (greater than 0.005").
 - i. **Remove** outer jam nut (Figure 15).
 - ii. **Pull** lock washer away from inner nut, but not entirely off the spindle.
 - iii. **Tighten** inner nut so its dowel aligns with the next alignment hole in the lock washer.

NOTE: If a smaller tightening increment is desired, remove lock washer from the spindle, flip it over, reinstall it on the spindle and tighten inner nut so its dowel aligns with the next alignment hole in the lock washer (Figure 17).

- iv. **Slide** lock washer up against inner nut and install outer jam nut.
- v. **Tighten** jam nut according to Table 3.
- vi. **Recheck** wheel bearing end play. Continue to adjust until end play is within the range specified, then go to Step A
- C. **If insufficient end play** (less than 0.001"):
 - i. Without rotating wheel, **remove** outer jam nut.
 - ii. **Pull** lock washer away from inner nut, but not entirely off spindle.
 - iii. **Loosen** inner adjusting nut so its dowel aligns with the previous alignment hole in lock washer.

NOTE: If a smaller loosening increment is desired, remove lock washer from spindle, flip it over, reinstall it on spindle and loosen inner adjusting nut so its dowel aligns with the previous alignment hole in lock washer (Figure 17).

- iv. **Slide** lock washer up against inner adjusting nut and install outer jam nut. Tighten nut according to Table 3 on page 15.
- v. **Repeat** CHECKING END PLAY on page 8, starting at Step 3.

11. Secure outer nut position:

- A. **3-piece nut** - install set screw (Figure 1 on page 5) into an accessible threaded hole

in lock washer (Figure 15). Set screw must contact inner adjusting nut. Tighten to 18±2 in. lbs. (2.0±0.0 Nm) of torque.

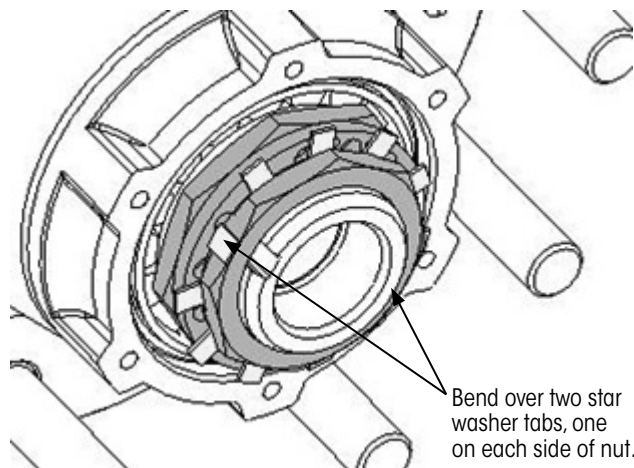

Figure 18: 4-piece nut system assembly (HN spindle only)

- B. **4-piece nut** - bend over two star washer tabs on opposite sides of the nut as shown in Figure 18.

Inspecting Installation

To ensure correct installation, follow these procedures:

1. **Ensure** lock washer is properly positioned and flush with inner adjusting nut at dowel pin (Figure 15 and Figure 17).
2. If three-piece, **ensure** set screw contacts nut face. When properly installed, the set screw will be approximately half the height of the outer jam nut.
3. If four-piece, ensure two tabs are folded over as shown in Figure 18.
4. **Test** for free hub rotation, perform CHECKING FOR SMOOTH ROTATION on page 8.

CASTLE SPINDLE NUT ASSEMBLY

A castle spindle nut is only applied to HP spindles that have been cross drilled to receive the cotter pin. Refer to Figure 8 on page 11 for illustration.

1. **Install** castle nut washer and castle nut onto spindle.
2. **Tighten** to 200 ft. lbs. (271 Nm) of torque while rotating hub at least one full rotation.
3. **Back off** castle nut until it begins to feel loose. **Do not exceed ½ turn.**
4. **Tighten** castle nut to 50 ft. lbs. (68 Nm) of torque while rotating hub at least one full rotation.

5. **Back off** nut 1/8 turn.
6. **Insert** cotter key, but do not bend at this time.
7. **Perform** CHECKING END PLAY on page 8.

IMPORTANT: End play must be between 0.001" (0.0254 mm) and 0.005" (0.127 mm).

- A. If end play is **within specifications**, go to Step 8.
- B. If end play is **out of tolerance**:
 - vi. **Remove** cotter key.
 - vii. If nut is too loose (greater than 0.005"), **tighten** nut by one alignment hole.

If nut is too tight (less than 0.001"), **loosen** nut one alignment hole.

- viii. **Reinstall** cotter key.
- ix. **Repeat** CHECKING END PLAY on page 8, starting at Step 3.

IMPORTANT: If the wheel-end includes TIREMAAX®, it is likely necessary to trim the cotter key (Figure 19) to avoid interference. Refer to T57001 *TIREMAAX CP & PRO Wheel-end considerations* for details. For more information on TIREMAAX, refer to www.Hendrickson-intl.com/TIREMAAX.

8. **Bend** the long leg of cotter pin to minimize castle nut movement.

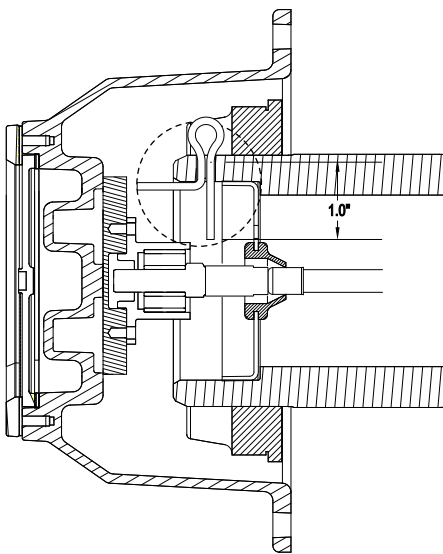

Figure 19: Cotter pin/TIREMAAX potential interference

NOTE: The cotter pin should extend into center of the spindle (Figure 19). If a hole in the spindle does not align with castle nut, loosen nut slightly until closest spindle hole aligns with a groove in castle nut.

9. Check to ensure:
 - A. Spindle castle nut is secure
 - B. Cotter key is properly installed and does not interfere with TIREMAAX® rotary union, if included.
 - C. If not already done so, perform CHECKING FOR SEAL LEAKS on page 7.

INSTALL HUBCAP

After hub installation and inspection is complete, the hubcap can be installed.

IMPORTANT: **Always** install a new gasket when reinstalling hubcap.

NOTICE

Accessory-type hubcaps, such as the chrome "top hat" style hubcap, increase wheel-end temperatures during operation and are not recommended for use on Hendrickson Standard or Extended Service wheel-ends.

NOTICE

Interference between nut system and hubcap could occur if improper components are used. Use only genuine Hendrickson or Hendrickson approved replacement components. Refer to [RELATIVE LITERATURE](#) on page 4 or [CONTACTING HENDRICKSON](#) on page 3 as needed.

1. **Visually inspect** hubcap, hub mating surface, screw holes and new gasket for:
 - Signs of damage
 - Debris, such as silicon gasket sealer
 - Burrs or sharp edges
 - Cracks
2. **Clean, repair or replace** as needed. Protect any exposed grease during the process. Replace any quantity of grease lost during the process.
3. **Align** hubcap and new gasket onto hub and **insert** screws.
4. **Hand-tighten** hubcap screws.



- Using a star pattern, **tighten** hubcap screws to 15 ± 3 ft. lbs. (21 ± 3 Nm) of torque.

NOTICE Do not overtighten hubcap screws. Overtightening will distort metal hubcap mounting flange, which will prevent hubcap from achieving a leak-free seal.

HUB LUBRICATION AFTER ASSEMBLY, OIL ONLY

For complete lubrication details, refer to:

- Lubricant manufacturer for compatibility among types.
- Seal and bearing manufacturer's recommendations for compatibility.
- Hub manufacturer for volumes.
- Fleet or OEM for lubricant type and other recommendations.

For adding lubricant, most hubs have a fill port and plug (Figure 1 on page 5) located on the side of the hub approximately halfway between the bearings. Standard service hubs will be filled with either oil or grease, as specified during original trailer build and fleet requirements.

IMPORTANT: If grease, DO NOT add grease through the hubcap fill port. Use of improper lubricants or maintenance procedures can void the wheel-end warranty.

NOTICE To minimize fretting and damage to wheel-end, lubricate all components and applicable surfaces using the same lubricant.

ADDING OIL LUBRICANT

Oil lubricant must be added after hub assembly and as needed.

- Remove** hub or hubcap lube fill port plug (Figure 1 on page 5) on the side of the hub or at the hubcap window plug (if included).

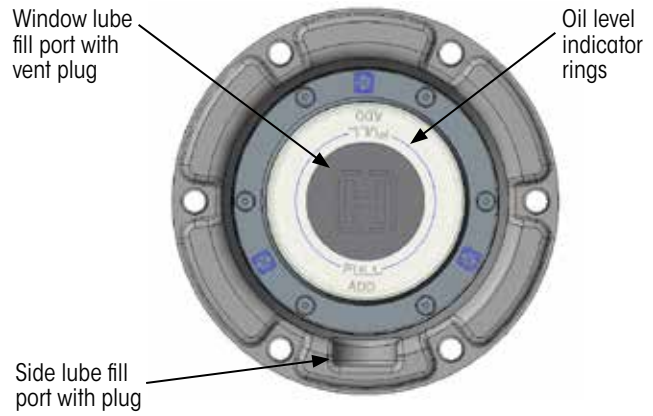

Figure 20: Sample oil hubcap with oil level indicator rings

NOTE: Not all hubs have a fill port. In this case, oil can only be added through the hubcap side or window lube fill port (Figure 20).

- Fill** wheel-end with oil until the oil level is above the "ADD" and to the "FULL" indicator ring of the hubcap window shown in Figure 20 and Figure 21.

DO NOT fill beyond this point

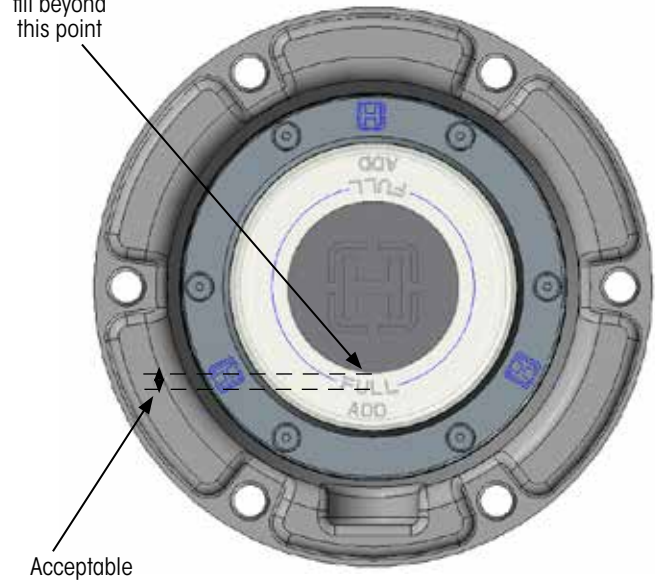

Figure 21: Fill levels for oil lubricant

IMPORTANT: The oil level should be maintained to the hubcap full indicator ring (Figure 21). Oil can be added to exceed the FULL line, but must remain below the spindle center. Oil levels above this risk contamination and loss of oil through the axle plus a reduction in lubricating performance.



If the lubricant is at or below the ADD line there is a risk of damage to bearings and other wheel-end components.

3. **Check** oil level at hubcap window.

NOTE: Allow sufficient time for oil to settle prior to final oil level check (it may be necessary to add oil more than once to adequately fill the wheel-end).

- A. **If** oil was inserted through the fill port in the **hub**, install fill port plug and tighten to 22±2 ft. lbs. (30±2 Nm) of torque.
- B. **If** oil was inserted through **hubcap** side fill port, install fill port plug and tighten to 7±2 ft. lbs. (10±2 Nm) of torque.

Otherwise, reinstall hubcap oil plug in window.

4. **Spin hub** more than three revolutions to distribute oil.

NLGI #2 GREASE LUBRICANT

Adequate NLGI #2 grease must be added during hub assembly (REMOVING AND INSTALLING HUB on page 10). Once assembled, additional grease will not serve to adequately lubricate bearings.

COMPLETING INSTALLATION

1. **Spin hub** more than three revolutions to distribute lubricant equally in hub bore.
2. If drum brake, **install brake drum**
3. If ADB, **install brake caliper** according to manufacturer's procedures. Refer to Hendrickson literature number T71004 *Hub and Rotor Assembly and Caliper Mounting* for information to reassemble ADB rotor and brake components. New caliper mounting hardware must be used.
4. **Install wheel** (tire and rim assembly) Refer to Brake DRUM AND WHEEL ASSEMBLY in Hendrickson literature number T82006 *Stud Replacement Procedures*.
5. If service is complete, **restore** trailer to normal operation.

ADDITIONAL INFORMATION

HUB SEMI FLUID GREASE DAM

Use of the hub semi fluid grease dam, during assembly, is the recommended method of lubricating the hub with semi fluid grease. Refer to HUB AND OUTER BEARING ASSEMBLY - SEMI FLUID GREASE on page 14 for instructions on how to use the Hub Semi Fluid Grease Dam.

MAKING A HUB SEMI FLUID GREASE DAM

To make a grease dam, follow the instructions on the face of the template (Figure 22 on page 20). Use cardboard, plastic or other flat stiff material.

TORQUE VALUES

Table 4 lists torque values for wheel-end fasteners.

FASTENER	TORQUE	
	ft. lbs.	Nm
Hubcap Hex Head Screws	15±3	21±3
Hub fill port plug	22±2	30±2
Hubcap side fill port plug	7±2	10±2
Wheel Nuts	475±25	645±30
STANDARD THREE- OR FOUR-PIECE SPINDLE NUT ASSEMBLY on page 15		
HN outer jam nut	315	427
HP outer jam nut	385	522
Set screw	18±2 in. lbs.	2.0±0.0
INSTALL HUBCAP		
Adjust nut according to procedure listed.		
THESE fasteners are incrementally tightened according to procedures defined in this manual and superseded by OEM documentation, where applicable. Refer to decal T70013 <i>Wheel Assembly Procedure</i> .		
RE-TORQUE all wheel nuts after 50 to 100 miles of service.		

Table 4: Standard Service Wheel-end fastener torque values

WHEEL STUD REMOVAL AND INSTALLATION PROCEDURE

Refer to Hendrickson literature number T82006 *Stud Replacement Procedures* for detailed instructions on wheel stud removal for both drum and disc applications.

Hub SF Grease Dam

1. Print one template for each spindle type (HN & HP).
2. Make a HN or HP grease dam from cardboard, plastic or other flat stiff material.
3. Use this grease dam when filling hub with semi-fluid grease to 50% full level.
4. Slide outer bearing over spindle and slide grease dam out while inseting bearing into hub.

For more details, refer to TMC RP 631.

HENDRICKSON
The World Rides On Us®

For assistance contact Hendrickson Technical Services
866-RIDEAIR (743-3247) or in Canada at 800-668-5360

Figure 22: Hub Semi Fluid Grease Dam template

Actual product performance may vary depending upon vehicle configuration, operation, service and other factors.

Call Hendrickson at **866.RIDEAIR (743.3247)** for additional information.



www.hendrickson-intl.com

TRAILER COMMERCIAL VEHICLE SYSTEMS

2070 Industrial Place SE
Canton, OH 44707-2641 USA
866.RIDEAIR (743.3247)
330.489.0045 • Fax 800.696.4416

Hendrickson Canada

250 Chrysler Drive, Unit #3
Brampton, ON Canada L6S 6B6
800.668.5360
905.789.1030 • Fax 905.789.1033

Hendrickson Mexicana

Circuito El Marqués Sur #29
Parque Industrial El Marqués
Pob. El Colorado, Municipio El Marqués,
Querétaro, México C.P. 76246
+52 (442) 296.3600 • Fax +52 (442) 296.3601

L496 Rev J 08-20 33704

Rev I 03-18 ECN 30425

Rev H 12-14 ECN 23249

Rev G 08-12 ECN 21353

Rev F 10-09 ECN 18525

© 1998 - 2020 Hendrickson USA, L.L.C. All Rights Reserved. All trademarks shown are owned by Hendrickson USA, L.L.C., or one of its affiliates, in one or more countries. Information contained in this literature was accurate at the time of publication. Product changes may have been made after the copyright date that are not reflected.

Printed in United States of America