



H TECHNICAL PROCEDURE

ROADMAAX™ 35K Rear Air Suspension for Fire and Rescue Vehicles

SUBJECT: Service Instructions

LIT NO: 17730-322

DATE: July 2019

REVISION: A

TABLE OF CONTENTS

Section 1	Introduction	2	Section 8	Component Replacement	
Section 2	Product Description	3		Fasteners	21
Section 3	Important Safety Notice	4		Height Control Valve • Linkage Assembly . . .	21
Section 4	Parts List	8		Air Spring	22
Section 5	Special Tools	9		Shock Absorber	24
Section 6	Preventive Maintenance			Shock Absorber Lower Mounting Bracket . . .	25
	Hendrickson Recommended			Cross Channel	26
	Preventive Maintenance Intervals	10		Clamp Group	28
	Component Inspection	10		Main Support Member	31
	U-bolt Clamp Group	11		Main Support Member Bushings	34
	Transverse TRAAX Rod	12		Frame Hanger	36
	Air Fittings	12		Transverse TRAAX Rod	37
	Shock Absorber	13	Section 9	Plumbing Diagram	39
Section 7	Alignment & Adjustments		Section 10	Torque Specifications	40
	Ride Height Adjustment	15	Section 11	Troubleshooting Guide	42
	Lateral Alignment	16			
	Pinion Angle	17			
	Drive Axle Alignment Inspection Procedure . .	17			
	Bar Pin Alignment	18			



SECTION 1

Introduction

This publication is intended to acquaint and assist maintenance personnel in the preventive maintenance, service, and repair of the ROADMAAX™ air suspension for applicable Fire and Rescue Vehicles.

NOTE

Use only Hendrickson Genuine parts for servicing this suspension system.

It is important to read and understand the entire Technical Procedure publication prior to performing any maintenance, service, or repair of this product. The information in this publication contains parts lists, safety information, product specifications, features, proper maintenance, service, and repair instructions for ROADMAAX air suspensions.

Hendrickson reserves the right to make changes and improvements to its products and publications at any time. Contact Hendrickson Tech Services for information on the latest version of this manual at 1-866-755-5968 (toll-free U.S. and Canada), 1-630-910-2800 (outside U.S. and Canada) or e-mail: techservices@hendrickson-intl.com.

The latest revision of this publication is available online at www.hendrickson-intl.com.

SECTION 2 Product Description

FIGURE 2-1

ROADMAAX with
Outboard Shock Absorber
Configuration

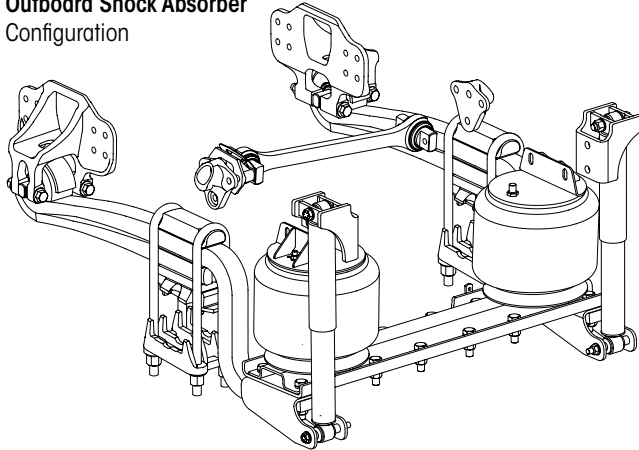

ROADMAAX with
Inboard Shock Absorber
Configuration

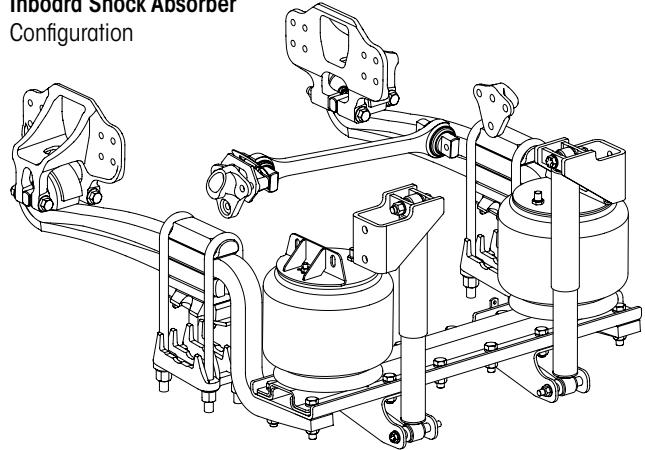

The **ROADMAAX** air suspension system – based on Hendrickson’s technology, proven in over two million suspensions – helps increase driver comfort and provides superior cargo protection. The ROADMAAX air suspension also helps to protect the vehicle from stress. The system combines superior comfort, outstanding ride, improved handling and reduced maintenance.

- **Air springs** – Adjusts to changing load conditions to deliver superior ride quality.
- **Axle connection** – No welding required for reduced maintenance.
- **Frame hanger** – Wide footprint distributes load over a larger area for reduced frame stress.
- **Height control valve** – Maintains precise ride height control through changing road surfaces, load, and driving conditions.
- **Main support member** – Extended-length generates lower spring rate for optimized roll stiffness, providing a more comfortable ride and better handling. Painted with proprietary zinc enriched paint for rust prevention.
- **Shock absorber** – Tuned for optimum damping characteristics to provide maximum driver comfort. Protects air springs during rebound. Outboard and inboard mounted shock configuration available.
- **TRAAX ROD™ torque rods** – Provides greater durability over conventional torque rods, exceptional bushing walk-out performance and enhances handling during cornering by controlling lateral forces to maintain axle position.

ROADMAAX SPECIFICATIONS

Suspension Capacity	35,000 Pound (15,876 kg)
Suspension Weight	783 - 823 Pound (355 - 373 kg)
Axle Configuration	Single or Tandem
Ride Heights	8.0", 8.5", 9.0", 9.5", 10.0", 10.5", 11.0", 11.5", 12.0"
Pinion Angle	2° – 12°

All applications must comply with applicable Hendrickson specifications and must be approved by the vehicle manufacturer with the vehicle in its original, as-built configuration.

All marks are trademarks of their respective owners.

SECTION 3

Important Safety Notice

Proper maintenance, service and repair are important to the reliable operation of the suspension. The procedures recommended by Hendrickson and described in this technical publication are methods of performing such maintenance, service and repair.

This technical publication should be read carefully to help prevent personal injury and to assure that proper methods are used. Improper maintenance, service or repair may damage the vehicle, cause personal injury, render the vehicle unsafe in operation, or void the manufacturer's warranty.

Failure to follow the safety precautions in this manual can result in personal injury and/or property damage. Carefully read and understand all safety related information within this publication, on all decals and in all such materials provided by the vehicle manufacturer before conducting any maintenance, service or repair.

EXPLANATION OF SIGNAL WORDS

Hazard "Signal Words" (Danger • Warning • Caution) appear in various locations throughout this publication. Information accented by one of these signal words must be observed to help minimize the risk of personal injury to service personnel, or possibility of improper service methods which may damage the vehicle or render it unsafe.



This is the safety alert symbol. It is used to alert you to potential personal injury hazards. Obey all safety messages that follow this symbol to avoid possible injury or death.

Additional Notes or Service Hints are utilized to emphasize areas of procedural importance and provide suggestions for ease of repair. The following definitions indicate the use of these signal words as they appear throughout the publication.



INDICATES AN IMMINENTLY HAZARDOUS SITUATION, WHICH IF NOT AVOIDED, WILL RESULT IN SERIOUS INJURY OR DEATH.



INDICATES A POTENTIAL HAZARDOUS SITUATION WHICH, IF NOT AVOIDED, CAN RESULT IN SERIOUS INJURY OR DEATH.



INDICATES A POTENTIAL HAZARDOUS SITUATION WHICH, IF NOT AVOIDED, MAY RESULT IN MINOR OR MODERATE INJURY.

NOTE

An operating procedure, practice condition, etc. which is essential to emphasize.

SERVICE HINT

A helpful suggestion that will make the service being performed a little easier and/or faster.

Also note that particular service operations may require the use of special tools designed for specific purposes. These special tools can be found in the "Special Tools" Section of this publication.



The torque symbol alerts you to tighten the fasteners to a specific torque value. See Torque Specifications Section of this publication.



■ SAFETY PRECAUTIONS

WARNING

FASTENERS

DISCARD USED FASTENERS. ALWAYS USE NEW FASTENERS TO COMPLETE A REPAIR. FAILURE TO DO SO COULD RESULT IN FAILURE OF THE PART, OR MATING COMPONENTS, ADVERSE VEHICLE HANDLING, PERSONAL INJURY, OR PROPERTY DAMAGE.

LOOSE OR OVER TORQUED FASTENERS CAN CAUSE COMPONENT DAMAGE, ADVERSE VEHICLE HANDLING, PROPERTY DAMAGE, OR SEVERE PERSONAL INJURY. MAINTAIN CORRECT TORQUE VALUE AT ALL TIMES. CHECK TORQUE VALUES ON A REGULAR BASIS AS SPECIFIED, USING A REGULARLY CALIBRATED TORQUE WRENCH. TORQUE VALUES SPECIFIED IN THIS TECHNICAL PUBLICATION ARE FOR HENDRICKSON SUPPLIED FASTENERS ONLY. IF NON-HENDRICKSON FASTENERS ARE USED, FOLLOW TORQUE SPECIFICATION LISTED IN THE VEHICLE MANUFACTURER'S SERVICE MANUAL.

WARNING

LOAD CAPACITY

ADHERE TO THE PUBLISHED CAPACITY RATINGS FOR THE SUSPENSION. ADD-ON AXLE ATTACHMENTS AND OTHER LOAD TRANSFERRING DEVICES CAN INCREASE THE SUSPENSION LOAD ABOVE ITS RATED AND APPROVED CAPACITIES, WHICH CAN RESULT IN COMPONENT DAMAGE AND ADVERSE VEHICLE HANDLING, POSSIBLY CAUSING PERSONAL INJURY OR PROPERTY DAMAGE.

WARNING

MODIFYING COMPONENTS

DO NOT MODIFY OR REWORK PARTS WITHOUT AUTHORIZATION FROM HENDRICKSON. DO NOT SUBSTITUTE REPLACEMENT COMPONENTS NOT AUTHORIZED BY HENDRICKSON. USE OF MODIFIED, REWORKED, SUBSTITUTE OR REPLACEMENT PARTS NOT AUTHORIZED BY HENDRICKSON MAY NOT MEET HENDRICKSON'S SPECIFICATIONS, AND CAN RESULT IN FAILURE OF THE PART, ADVERSE VEHICLE HANDLING, POSSIBLE PERSONAL INJURY OR PROPERTY DAMAGE, AND WILL VOID ANY APPLICABLE WARRANTIES. USE ONLY HENDRICKSON AUTHORIZED REPLACEMENT PARTS.

WARNING

TORCH/WELDING

DO NOT USE A CUTTING TORCH TO REMOVE ANY FASTENERS OR BUSHINGS. THE USE OF HEAT ON SUSPENSION COMPONENTS WILL ADVERSELY AFFECT THE STRENGTH OF THESE PARTS. A COMPONENT DAMAGED IN THIS MANNER CAN RESULT IN THE ADVERSE VEHICLE HANDLING AND POSSIBLE PERSONAL INJURY OR PROPERTY DAMAGE.

EXERCISE EXTREME CARE WHEN HANDLING OR PERFORMING MAINTENANCE IN THE AREA OF THE MAIN SUPPORT MEMBER. DO NOT CONNECT ARC WELDING GROUND LINE TO THE MAIN SUPPORT MEMBER. DO NOT STRIKE AN ARC WITH THE ELECTRODE ON THE MAIN SUPPORT MEMBER AND AXLE. DO NOT USE HEAT NEAR THE MAIN SUPPORT MEMBER ASSEMBLY. DO NOT NICK OR GOUGE THE MAIN SUPPORT MEMBER. SUCH IMPROPER ACTIONS CAN DAMAGE THE MAIN SUPPORT MEMBER ASSEMBLY AND CAUSE ADVERSE VEHICLE HANDLING AND POSSIBLE PERSONAL INJURY OR PROPERTY DAMAGE.

WARNING

PERSONAL PROTECTIVE EQUIPMENT

ALWAYS WEAR PROPER EYE PROTECTION AND OTHER REQUIRED PERSONAL PROTECTIVE EQUIPMENT TO HELP PREVENT PERSONAL INJURY WHEN PERFORMING VEHICLE MAINTENANCE, REPAIR OR SERVICE.

CAUTION

PROCEDURES AND TOOLS

A TECHNICIAN USING A SERVICE PROCEDURE OR TOOL WHICH HAS NOT BEEN RECOMMENDED BY HENDRICKSON MUST FIRST SATISFY HIMSELF THAT NEITHER HIS SAFETY NOR THE VEHICLE'S SAFETY WILL BE JEOPARDIZED BY THE METHOD OR TOOL SELECTED. INDIVIDUALS DEVIATING IN ANY MANNER FROM THE INSTRUCTIONS PROVIDED WILL ASSUME ALL RISKS OF CONSEQUENTIAL PERSONAL INJURY OR DAMAGE TO EQUIPMENT INVOLVED.

 **WARNING****SUPPORT THE VEHICLE PRIOR TO SERVICING**

PLACE THE VEHICLE ON A LEVEL FLOOR AND CHOCK THE WHEELS TO PREVENT THE VEHICLE FROM MOVING OR ROLLING. DO NOT WORK AROUND OR UNDER A RAISED VEHICLE SUPPORTED BY ONLY A FLOOR JACK OR OTHER LIFTING DEVICE. ALWAYS SUPPORT A RAISED VEHICLE WITH RIGID SAFETY STANDS. FAILURE TO DO SO CAN CAUSE SERIOUS PERSONAL INJURY OR DAMAGE TO EQUIPMENT.

 **WARNING****AIR SPRING INFLATION AND DEFLATION**

PRIOR TO DISASSEMBLY OF THE SUSPENSION, AIR SPRING ASSEMBLIES MUST BE DEFLATED. UNRESTRICTED AIR SPRING ASSEMBLIES CAN VIOLENTLY SHIFT. DO NOT INFLATE AIR SPRING ASSEMBLIES WHEN THEY ARE UNRESTRICTED. AIR SPRING ASSEMBLIES MUST BE RESTRICTED BY SUSPENSION OR OTHER ADEQUATE STRUCTURE. DO NOT INFLATE BEYOND PRESSURES RECOMMENDED BY AIR SPRING MANUFACTURER. CONTACT HENDRICKSON TECHNICAL SERVICES FOR DETAILS. IMPROPER USE OR OVER INFLATION MAY CAUSE AIR SPRING ASSEMBLIES TO BURST, CAUSING PROPERTY DAMAGE AND/OR SEVERE PERSONAL INJURY.

 **WARNING**

PRIOR TO AND DURING DEFLATION AND INFLATION OF THE AIR SUSPENSION SYSTEM, ENSURE ALL PERSONNEL AND EQUIPMENT ARE CLEAR FROM UNDER THE VEHICLE AND AROUND THE SERVICE AREA, FAILURE TO DO SO CAN CAUSE SERIOUS PERSONAL INJURY, DEATH, OR PROPERTY DAMAGE.

 **CAUTION****AIR SPRING INFLATION**

INFLATE THE SUSPENSION SLOWLY AND MAKE SURE THE RUBBER BLADDER OF THE AIR SPRING INFLATES UNIFORMLY AND IS NOT BINDING. FAILURE TO DO SO CAN CAUSE DAMAGE TO THE AIR SPRING AND/OR MOUNTING BRACKETS AND VOID WARRANTY.

 **CAUTION****AIR SPRING LOWER MOUNTING STUDS**

IF THE AIR SPRING IS BEING REMOVED FOR AN ALTERNATE REPAIR, IT IS MANDATORY TO LUBRICATE THE LOWER AIR SPRING FASTENERS WITH PENETRATING OIL AND REMOVE WITH HAND TOOLS TO PREVENT DAMAGE TO THE LOWER AIR SPRING MOUNTING STUD. FAILURE TO DO SO CAN CAUSE COMPONENT DAMAGE AND VOID WARRANTY.

 **WARNING****TRANSVERSE RODS**

THE ROADMAAX AIR SUSPENSION INCORPORATES TRANSVERSE RODS FOR VEHICLE STABILITY. IF THESE COMPONENTS ARE DISCONNECTED OR ARE NON-FUNCTIONAL THE VEHICLE SHOULD NOT BE OPERATED. FAILURE TO DO SO CAN RESULT IN ADVERSE VEHICLE HANDLING, POSSIBLE TIRE CONTACT WITH THE FRAME, SEVERE PERSONAL INJURY, AND PREMATURE COMPONENT DAMAGE.

 **WARNING****U-BOLT FASTENERS**

U-BOLTS THAT ARE FOUND TO BE LOOSE REQUIRE THAT MATING COMPONENTS BE INSPECTED FOR SIGNS OF WEAR. ANY WORN COMPONENTS MUST BE REPLACED. FAILURE TO DO SO CAN CAUSE PREMATURE CLAMP GROUP FAILURE, COMPONENT DAMAGE, ADVERSE VEHICLE HANDLING, PROPERTY DAMAGE, OR SEVERE PERSONAL INJURY. MAINTAIN CORRECT TORQUE VALUES AT ALL TIMES. CHECK TORQUE VALUES ON A REGULAR BASIS AS SPECIFIED.

 **WARNING****MAIN SUPPORT MEMBER**

FAILURE OF THE MAIN SUPPORT MEMBER BETWEEN THE U-BOLTS WILL REQUIRE THE REPLACEMENT OF THE MAIN SUPPORT MEMBER AND ALL CLAMP GROUP COMPONENTS. FAILURE TO DO SO CAN RESULT IN CLAMP GROUP FAILURE AND FURTHER FAILURE TO THE MAIN SUPPORT MEMBER, WHICH CAN CAUSE ADVERSE VEHICLE HANDLING, PROPERTY DAMAGE OR SEVERE PERSONAL INJURY.

 **WARNING****CROSS CHANNEL**

IMPROPER JACKING METHODS CAN CAUSE STRUCTURAL DAMAGE WHICH CAN CAUSE ADVERSE VEHICLE HANDLING, PROPERTY DAMAGE OR SEVERE PERSONAL INJURY AND WILL VOID HENDRICKSON'S WARRANTY.

- DO NOT USE THE SUSPENSION CROSS CHANNEL AS A JACKING POINT
- REFER TO VEHICLE MANUFACTURER FOR PROPER JACKING INSTRUCTIONS



 **WARNING**

PARTS CLEANING

SOLVENT CLEANERS CAN BE FLAMMABLE, POISONOUS, AND CAUSE BURNS. TO HELP AVOID SERIOUS PERSONAL INJURY, CAREFULLY FOLLOW THE MANUFACTURER'S PRODUCT INSTRUCTIONS AND GUIDELINES AND THE FOLLOWING PROCEDURES:

1. WEAR PROPER EYE PROTECTION.
2. WEAR CLOTHING THAT PROTECTS YOUR SKIN.
3. WORK IN A WELL-VENTILATED AREA.
4. DO NOT USE GASOLINE OR SOLVENTS THAT CONTAIN GASOLINE. GASOLINE CAN EXPLODE.
5. HOT SOLUTION TANKS OR ALKALINE SOLUTIONS MUST BE USED CORRECTLY. FOLLOW THE MANUFACTURER'S RECOMMENDED INSTRUCTIONS AND GUIDELINES CAREFULLY TO HELP PREVENT PERSONAL ACCIDENT OR INJURY.

DO NOT USE HOT SOLUTION TANKS OR WATER AND ALKALINE SOLUTIONS TO CLEAN GROUND OR POLISHED PARTS. DOING SO WILL CAUSE DAMAGE TO THE PARTS AND VOID WARRANTY.

SECTION 4 Parts List

Refer to the specific parts list for your vehicle available online at <https://hendrickson-intl.com/Truck/Fire-Rescue/ROADMAAX>

FIGURE 4-1

ROADMAAX™ for fire/rescue ROSENBAUER TRAK
High Capacity Rear Air Suspension for Fire and Rescue

ROADMAAX is designed specifically for heavy-duty fire and rescue markets with ride quality and equipment protection being its cornerstone features. The suspension delivers enhanced stability, handling and ride quality even in the most challenging environments where vehicles encounter sharp turns and unexpected ground and environmental conditions. The integration of Hendrickson's proven main support member spring technology, with its wide stance air springs, provides a balance of predictable handling and ride quality even in the most demanding environments.

LITERATURE
SALES LITERATURE
45745-407 - ROADMAAX Fire/Rescue Flyer REV A | 04/19 | 4549

PARTS LISTS
SP-322 ROADMAAX Parts List for Rosenbauer Vehicles REV A | 02/19 | 1836

FEATURES & BENEFITS

Superior Ride

- The main support members extended length generates lower spring rate for optimized roll stiffness providing a more comfortable and compliant ride
- Longer main support member allows the air springs to carry more of the vertical load
- Shocks are tuned for optimum damping characteristics to provide maximum driving comfort
- Air springs adjust to changing load conditions to deliver superb ride quality
- Fast acting height control valves maintain precise ride height control through changing road surfaces, loads and driving conditions

Exceptional Stability and Handling

- Durable Hendrickson torque rods enhance handling during cornering by controlling lateral forces to maintain axle position
- The main support member is efficiently designed to provide neutral roll steer for better handling

Reduced Maintenance

- Wide footprint of the frame hanger bracket distributes load over a larger area for reduced frame stress
- Fabricated heavy-duty torque rods provide greater durability over conventional rods



SECTION 5 Special Tools

MAIN SUPPORT MEMBER BUSHING TOOLS

These shop made tools are designed for servicing main support member bushings. Bushing tools are made from cold rolled steel or equivalent. The drawings are for reference only, Hendrickson does not supply these tools.

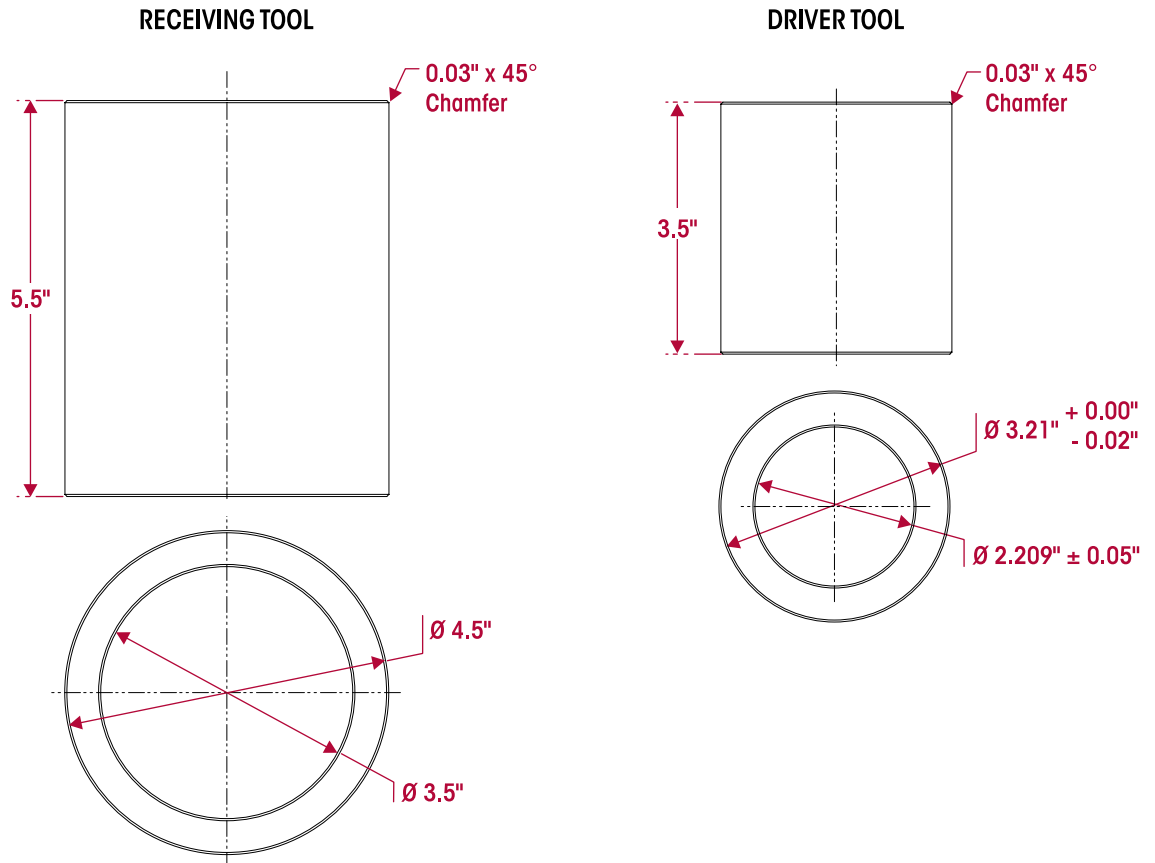

SECTION 6

Preventive Maintenance

Following appropriate inspection procedures is important to help ensure the proper maintenance and operation of the ROADMAAX air suspension system and component parts function to their highest efficiency. Look for bent or cracked parts. Replace all worn or damaged parts.

HENDRICKSON RECOMMENDED PREVENTIVE MAINTENANCE INTERVALS

- Preparation for delivery
- The first 1,000 miles (1,600 kilometers)
- On-highway – every 20,000 miles (32,000 kilometers) or every 6 months, whichever comes first

COMPONENT INSPECTION

- **Air spring** – Look for chafing or any signs of spring or component damage. Ensure that the upper bead plate is tight against the underside of the frame. Check for any lateral slippage at the lower air spring bracket. Replace all worn or damaged parts.
- **Clamp group** – Visually inspect for any loose or damaged fasteners. Verify the U-bolt hex nuts have the proper torque values maintained. See the U-bolt Clamp Group Connection in this section.
- **Cross channel** – Check for cracks, damage, metal shavings, or looseness at the main support member connection. Replace all worn or damaged parts.
- **Fasteners** – Look for any loose or damaged fasteners on the entire suspension. Make sure all fasteners are tightened to a torque value within the specified torque range. See Torque Specifications Section of this publication for recommended torque requirements. Use a calibrated torque wrench to check torque in a tightening direction. As soon as the fastener starts to move, record the torque. Correct the torque if necessary. Replace any worn or damaged fasteners with genuine specified fasteners.
- **Frame hanger** – Check for any signs of loosening or damage at the main support member connections. Check for cracks, damage, or any signs of looseness at the mounting fasteners. Replace all worn or damaged parts.
- **Height control valve and air lines** – Check the suspension air system for air leaks. Check all air lines for proper routing. Check for chafing or pinched air lines. Check the height control valve linkage for damage or interference with peripheral components. Replace all worn or damaged parts.
- **Main support member assembly** – Look for signs of looseness, cracks, or other damage. Inspect the cross channel connection for looseness or damage. Check torque on bushing, cross channel and U-bolts. Correct the torque if necessary. Replace all worn or damaged parts.
- **Shock absorbers** – Look for any signs of dents or leakage. See Shock Absorber in this section.
- **Tire wear** – Inspect the tires for wear patterns that may indicate suspension damage or misalignment. Replace all worn or damaged parts.
- **Transverse TRAAX ROD** – All torque rods must be inspected for looseness, torn or shredded rubber, and for proper torque. If there is metal-to-metal contact in the bushing joint, this is a sign of excessive bushing wear and the bushing needs to be replaced. Replace all worn or damaged parts.
- **Wear and damage** – Inspect all parts of the suspension for wear and damage. Look for bent or cracked parts. Replace all worn or damaged parts.

See vehicle manufacturer's applicable publications for other preventive maintenance requirements.

U-BOLT CLAMP GROUP

NOTE

Hendrickson U-bolt clamp group hardware for the ROADMAAX air suspension are phosphate and oil coated M24 locknuts and U-bolts.

WARNING

IT IS IMPORTANT THAT THE U-BOLT CLAMP GROUP CONNECTION BE PROPERLY ALIGNED AND HAVE THE PROPER TIGHTENING TORQUE VALUES MAINTAINED. METAL SURFACES CAN WORK AND WEAR AGAINST OTHER RELATED CLAMP GROUP COMPONENTS IF NOT PROPERLY ALIGNED OR PROPERLY TIGHTENED TO MAINTAIN THE PROPER CLAMP FORCE. FAILURE TO DO SO CAN CAUSE PREMATURE COMPONENT WEAR, POSSIBLE SEPARATION OF THE CLAMP GROUP, CAUSING ADVERSE VEHICLE HANDLING, PROPERTY DAMAGE, OR PERSONAL INJURY.

Maintaining the correct U-bolt torque value is important to help ensure proper suspension component performance.

1. Inspect the U-bolts for proper seating of components, i.e. no gaps, etc.
2. U-bolt hex nuts must be torqued to specification, see Figure 6-1. **DO NOT** exceed specified torque on U-bolt hex nuts.

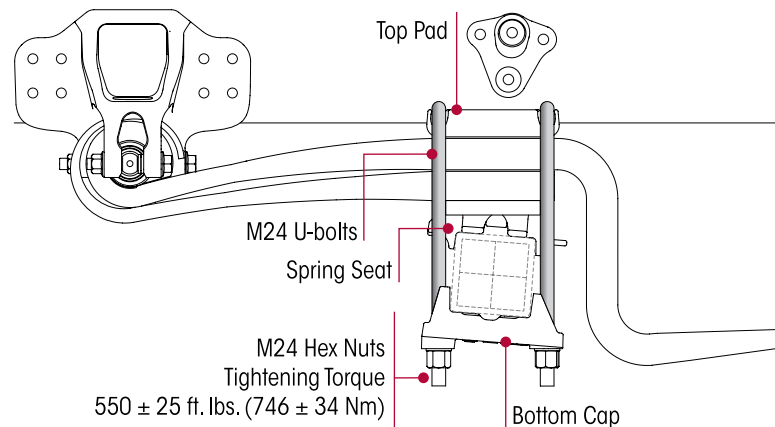
FIGURE 6-1

3. U-bolt hex nuts must be re-torqued at the following intervals:
 - At preparation for delivery.
 - At 1000 mile of service on a new vehicle or vehicle with serviced axle attachment assembly.
 - Thereafter follow the 6 months / 20,000 miles visual inspection and annual re-torque interval.

4. Tighten the U-bolt hex nuts in the proper sequence, shown in Figure 6-2, evenly in 50 foot pounds increments to achieve uniform bolt tension to 550 ± 25 foot pounds torque.

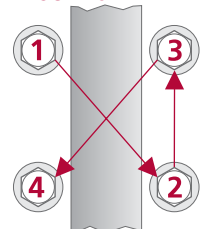
FIGURE 6-2

WARNING

TRANSVERSE TRAAX ROD

THE ROADMAAX AIR SUSPENSION INCORPORATES TRANSVERSE TRAAX RODS FOR VEHICLE STABILITY. IF THESE COMPONENTS ARE DISCONNECTED OR ARE NON-FUNCTIONAL THE VEHICLE SHOULD NOT BE OPERATED. FAILURE TO DO SO CAN RESULT IN ADVERSE VEHICLE HANDLING, POSSIBLE TIRE CONTACT WITH THE FRAME, SEVERE PERSONAL INJURY, AND PREMATURE COMPONENT DAMAGE.

VISUAL INSPECTION

All transverse TRAAX RODS need to be inspected during preventive maintenance and service for looseness.

Visually inspect (1) torque rod bushings for any torn or shredded rubber material interfaces or elongated oval shapes and **(2) torque rods** for any metal to metal contact, bent, cracked or broken components. The torque rod will require replacement if any of these conditions are encountered.

Torque rod looseness inspection is necessary. With the vehicle shut down, a lever check can be made with a long pry bar placed under each torque rod end and pressure applied.

Torque rod length is determined by the original vehicle manufacturer (see Figure 6-3).

The transverse torque rods also control axle walk-out during cornering. The mounting bracket at the axle housing end of the torque rods are furnished and welded into position on the axle housings by the axle or vehicle manufacturer, see Figure 6-3.

If the lateral alignment of the axles is incorrect, it may be necessary to shim the transverse torque rod at the straddle mount end, see Figure 6-3. Refer to Lateral Alignment in the Alignment & Adjustments Section of this publication.

FIGURE 6-3

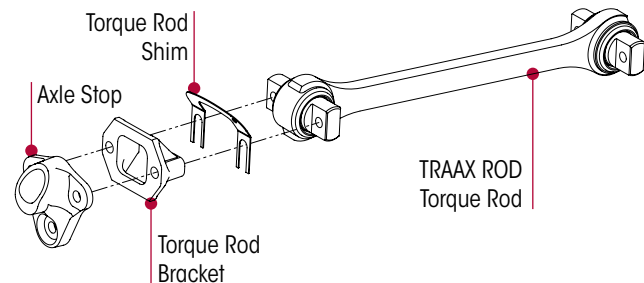

NOTE

Hendrickson Suspension recommends Grade 8 bolts, hardened flat washer and Grade C locknuts be used for all straddle mount torque rod attachments.

It is important that the **tightening torque** of the locknuts be checked during preventive maintenance and service. Follow the tightening torque specifications and all applicable preventive maintenance, service and safety instructions issued by the respective vehicle and suspension manufacturers.

AIR FITTINGS

INSPECTION

NOTE

Air lines and fittings may be inspected for leaks using a soapy water solution. The height control valve, however, cannot be inspected using this method. All height control valves have an allowable leakage rate.

1. If an air leak is suspected, begin by building up the air system to normal operating pressure.
2. Spray all nylon tube air fittings with a soapy water solution to detect the leak location.
3. If an air leak is located, ensure the tubing end is clean and in good condition and the end is cut square. Check to see if the tubing is binding, bent or being pulled upon.
4. Visually inspect the air fitting's O-ring seal for signs of damage or contamination.



SHOCK ABSORBER

NOTE

It is not necessary to replace shock absorbers in pairs if only one (1) shock absorber requires replacement.

Hendrickson uses a long service life, premium shock absorber on all ROADMAAX air suspensions. When the shock absorber replacement is necessary, Hendrickson recommends that the shock absorbers be replaced with identical Hendrickson Genuine parts for servicing. Failure to do so will affect the suspension performance, durability, and will void any applicable warranty. See vehicle manufacturer's applicable publications for other shock absorber inspection requirements.

Inspection of the shock absorber can be performed by doing a heat test, and a visual inspection. Replace as necessary, refer to the Component Replacement Section of this publication.

HEAT TEST

1. Drive the vehicle at moderate speeds on rough road for minimum of fifteen minutes.



WARNING

DO NOT GRAB THE SHOCK ABSORBER AS IT COULD POSSIBLY BE HOT AND CAUSE PERSONAL INJURY.

2. Use an infrared thermometer to check the temperature of the shock absorber. This can also be performed by carefully touching the shock absorber body below the dust cover. Touch the frame to get an ambient reference, see Figure 6-4. A warm shock absorber is acceptable, a cold shock absorber should be replaced.
3. To inspect for an internal failure, remove and shake the suspected shock absorber. Listen for the sound of metal parts rattling inside. Rattling of metal parts can indicate that the shock absorber has an internal failure and the shock absorber should be replaced.

FIGURE 6-4



VISUAL INSPECTION

Look for these potential problems when doing a visual inspection. Inspect the shock absorbers fully extended. Replace as necessary.

FIGURE 6-5

SHOCK ABSORBER VISUAL INSPECTION - UNACCEPTABLE CONDITIONS



LEAKING VS. MISTING SHOCK ABSORBER VISUAL INSPECTION

The inspection must not be conducted after driving in wet weather or a vehicle wash. The shock absorber needs to be free from water. Many shock absorbers are often misdiagnosed as failures. Misting is the process whereby very small amounts of shock absorber fluid evaporate at a high operating temperature through the upper seal of the shock absorber. When the “mist” reaches the cooler outside air, it condenses and forms a film on the outside of the shock absorber body. Misting is perfectly normal and necessary function of the shock absorber. The fluid which evaporates through the seal area helps to lubricate and prolong the life of the seal.

NOTE

ROADMAAX air Suspension systems are equipped with a premium seal on the shock absorber, however this seal will allow for misting to appear on the shock absorber body (misting is not a leak and is considered acceptable).

Inspect the shock absorber fully extended. **A shock absorber that is truly leaking** will show signs of fluid **leaking in streams from the upper seal**. These streams can easily be seen, underneath the main body (dust cover) of the shock absorber. Replace as necessary.

FIGURE 6-6

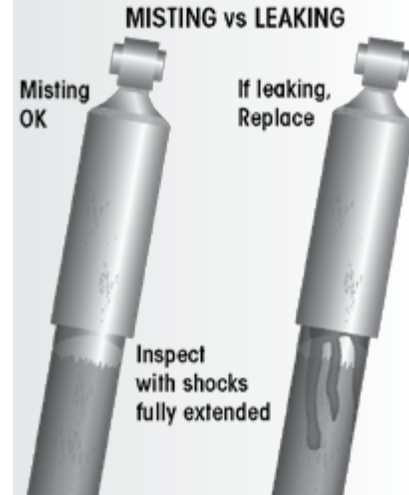

SECTION 7

Alignment & Adjustments

RIDE HEIGHT ADJUSTMENT

NOTE

If the height control valve is not supplied by Hendrickson, refer to the vehicle manufacturer's instructions for inspection, maintenance and rebuild instructions.

1. Use a work bay with a level surface.
 2. Relax the suspension by slowly moving the vehicle back and forth several times in a straight line without using the brakes. This will slacken or loosen the suspension as the vehicle is positioned. End with all wheels positioned straight ahead.
 3. **DO NOT** set the parking brake. Chock the front wheels of the vehicle.
 4. Verify the air system is at full operating pressure.
 5. See Air Spring Warnings and Instructions in the Important Safety Notice Section of this publication prior to deflating or inflating the air system.
 6. Cycle the air system. Disconnect the height control valve arm from the rubber grommet. Lower the height control valve arm to exhaust the air in the air springs and deflate the suspension. Reconnect the height control valve arm to the rubber grommet to inflate the suspension.
- **Ride height** is measured at the bottom of the frame rail to the centerline of the axle as shown in Figure 7-1.

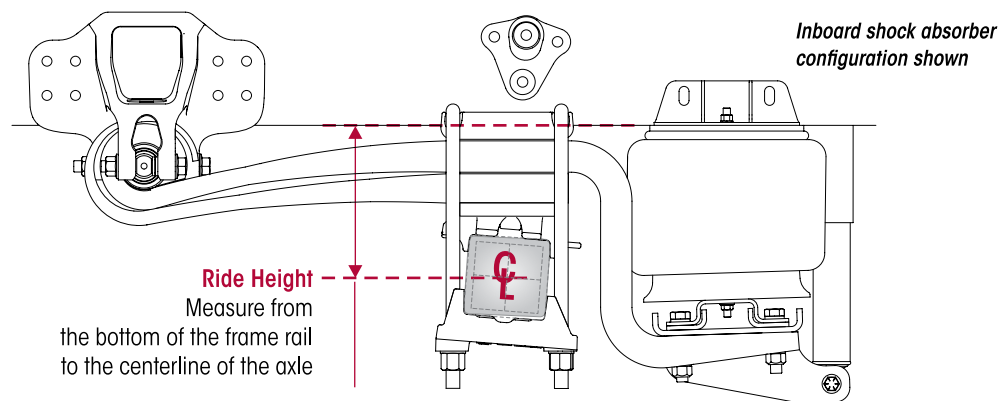
FIGURE 7-1

7. If an adjustment is required, verify that the air system is at full operating pressure.

WARNING

PRIOR TO AND DURING DEFLATION AND INFLATION OF THE AIR SUSPENSION SYSTEM, ENSURE THAT ALL PERSONNEL AND EQUIPMENT ARE CLEAR FROM UNDER THE VEHICLE AND AROUND THE SERVICE AREA, FAILURE TO DO SO CAN CAUSE SERIOUS PERSONAL INJURY, DEATH, OR PROPERTY DAMAGE.

8. See additional Air Spring Cautions and Warnings in the Important Safety Notice Section of this publication prior to deflating or inflating the air system.
9. Disconnect the height control valve arm from the rubber grommet. Lower the height control valve arm to exhaust the air from the air springs and deflate the rear suspension.
10. Refill the suspension by raising the height control valve arm by hand, so that the suspension is above the proper ride height.

11. Lower the height control valve arm to exhaust the air system until the suspension is at proper ride height.
12. Use a 3 mm wooden dowel rod (golf tee) to set the neutral position for the height control valve by aligning the hole in the height control valve arm with the hole in the height control valve cover, as shown in Figure 7-2. **DO NOT** use a metal rod or nail as this may cause damage to the height control valve.
13. Adjust the extension rod assembly so the rubber grommet can be reconnected to the height control valve arm at the proper height. Check the rubber components for any tearing or damage, replace as necessary.
14. Reconnect the height control valve arm to the rubber grommet.
15. Tighten the clamp on the adjustable valve arm joint with a screwdriver until securely fastened.
16. Remove the dowel from the height control valve.
17. If equipped with a suspension dump system in the cab, cycle the suspension air system by using the cab dump valve control. If not equipped with a dump valve, cycle the height control valve arm as stated in Steps numbers 4 through 6 above.
18. Recheck the ride height.
19. Repeat Steps 3 through 18 until the ride height is within specification.

FIGURE 7-2

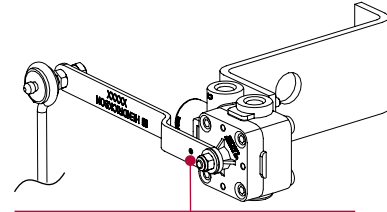

To set neutral position align hole with hole on height control valve cover.

SERVICE HINT

It is very important that the leveling valve be cycled completely before and after any ride height adjustments. The cycling of the leveling valve will help make the adjustment more accurate. Be sure to maintain full system air pressure while setting or inspecting ride height.

NOTE

During cycle operation of the height control valve it is normal to experience a limited amount of exhaust noise.

LATERAL ALIGNMENT

1. Use a work bay with a level floor.
2. Drive the vehicle slowly, straight ahead. Try to slacken or loosen the suspension as the vehicle is positioned. End with all wheels positioned straight ahead. Try to roll to a stop without the brakes being used.
3. **DO NOT** set the parking brake. Chock the front wheels of the vehicle.
4. Verify and maintain the air system at full operating pressure.
5. Verify the vehicle is at the correct ride height. Correct as necessary. Refer to Ride Height Adjustment in this section.
6. Verify all suspension components are in good condition. Repair or replace any worn or damaged suspension components before proceeding with the alignment process.
7. Ensure all drive axle tires are the same size and properly inflated.
8. Measure from the outside of the frame rail to the rim flange of the inner tire. Record the measurement **A**, see Figure 7-3.
9. Measure the same distance on the opposite side of the same axle. Record the measurement **B**, see Figure 7-3.

FIGURE 7-3

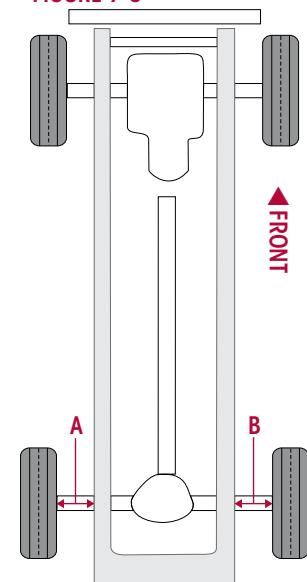

10. Subtract the two measurements to get a difference between the two. Verify the difference is within the vehicle manufacturer's specifications. Adding or removing shims that are located between the transverse torque rod and the torque rod bracket, see Figure 7-4, will normally correct the axle lateral alignment.

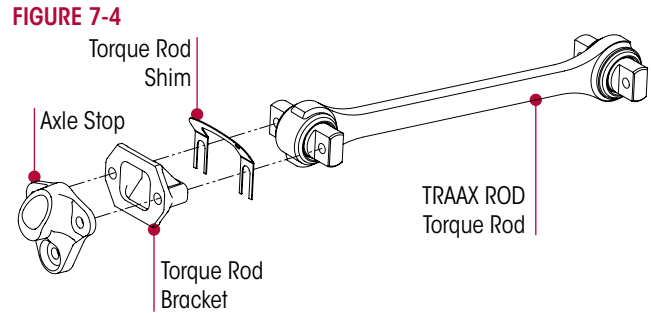
SERVICE HINT

A general rule of thumb is to use a torque rod shim with a thickness that is half of the difference between the two measurements.

It is important to check the transverse torque rod fasteners for proper torque during preventive maintenance service intervals. Refer to Torque Specifications Section of this publication.

PINION ANGLE

The vehicle manufacturer establishes drive axle pinion angles. If it is necessary to fine-tune the pinion angle it will be necessary to contact the vehicle manufacturer.

TO CHECK THE PINION ANGLE

1. Use a work bay with a level floor. Drive the vehicle slowly, straight ahead. Try to slacken or loosen the suspension as the vehicle is positioned. End with all wheels positioned straight ahead.
2. Verify vehicle is at the proper ride height, see Ride Height Adjustment in this section.
3. Install a digital protractor on the drive axle housing as shown in Figure 7-5.
4. Verify the pinion angle is correct per the vehicle manufacturer's specifications. If an adjustment is needed please contact the vehicle manufacturer.

FIGURE 7-5

DRIVE AXLE ALIGNMENT INSPECTION PROCEDURE

Proper alignment is essential for maximum ride quality, performance, and tire service life. This procedure should be performed if excessive or irregular tire wear is observed. The following recommended alignment procedure should be performed after all repairs are completed and all suspension fasteners have been tightened to specified torque values.

NOTE

Computerized alignment equipment is the preferred method of measuring alignment. Proper vehicle alignment can only be achieved when all axles are aligned to the vehicle's centerline and the steering axle's caster, camber and toe-in settings are within specifications. If, however, axle alignment equipment is not available the alignment of the drive axle may be checked by performing the following steps.

1. Use a work bay with a level surface.
2. Relax the suspension by slowly moving the vehicle back and forth several times in a straight line without using the brakes. This will slacken or loosen the suspension as the vehicle is positioned. End with all wheels positioned straight ahead.
3. **DO NOT** set the parking brake.

4. Chock the **front** wheels of the vehicle.
5. Verify and maintain the air system at full operating pressure.
6. Verify the vehicle is at the correct ride height. Correct as necessary. Refer to Ride Height Adjustment in this section.
7. Verify all suspension components are in good condition. Repair or replace any worn or damaged suspension components before proceeding with the alignment process.

FIGURE 7-6

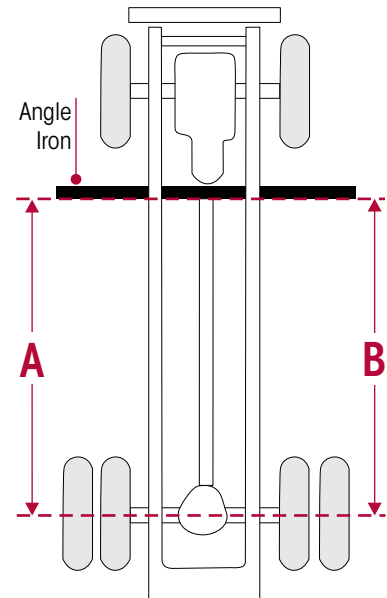

8. Ensure all drive axle tires are the same size and air up to the proper PSI.
9. If axle alignment equipment is not available, using "C" clamps, securely clamp a six-foot piece of STRAIGHT bar stock or angle iron across the lower frame flange as shown in Figure 7-6. Select a location for the angle iron as far forward of the drive axle as possible where components will not interfere.
10. Accurately square the straight edge to the frame using a carpenter's square.
11. Using a measuring tape, measure from the straight edge to the forward face of the front drive axle arms at the centerline on both sides of the vehicle as shown in Figure 7-6, measure **A** and **B**.
12. Calculate the difference between measurements **A** and **B**.
 - a. If the front drive axle is within vehicle manufacturer's specifications, then the alignment of drive axle is acceptable.
 - b. If alignment of the front drive axle **IS NOT** within the vehicle manufacturer's specifications, then contact vehicle manufacturer.
13. Following alignment of axle, move vehicle back and forth several times prior to removing straight edge from frame, and recheck measurements to confirm adjustments.
14. After the drive axle is aligned, check the pinion angle of drive axle with a digital protractor, see Figure 7-5. Refer to vehicle manufacturer's specifications for the required pinion angles.

BAR PIN ALIGNMENT

The nominal bar pin alignment consists of four (4) $\frac{3}{16}$ " thick gray shims between each bar pin end and the hanger legs, see Figures 7-7 and 7-10.

- **DO NOT** install or stack more than two $\frac{3}{16}$ " gray shims at each bolt location.

Post alignment adjustment, there may be a different configuration as shown in Figures 7-7 and 7-11, which may contain yellow $\frac{3}{32}$ " shims.

- **DO NOT** install or stack more than one $\frac{3}{16}$ " gray shim and two $\frac{3}{32}$ " yellow shims at each bolt location.

NOTE

Both sides of the bar pin must have an identical configuration of shims.

WARNING

BAR PIN SHIMS MUST BE INSTALLED PER BOLT LOCATION. THE SAME PART NUMBER SHIMS IN THE SAME ORIENTATION MUST BE USED AT BOTH BOLT LOCATIONS ON ANY ONE END OF BUSHING, SEE FIGURE 7-7. DO NOT INSTALL OR STACK MORE THAN REQUIRED SHIMS AT EACH BOLT LOCATION. USE GENUINE HENDRICKSON BAR PIN SHIMS, DO NOT USE STANDARD WASHER. FAILURE TO FOLLOW THESE WARNING MAY RESULT IN IMPROPER VEHICLE ALIGNMENT, FRACTURE OF THE FRAME HANGER LEGS OR BAR PIN WHICH COULD RESULT IN THE LOSS OF VEHICLE CONTROL AND POSSIBLE PERSONAL INJURY OR PROPERTY DAMAGE.



FIGURE 7-7

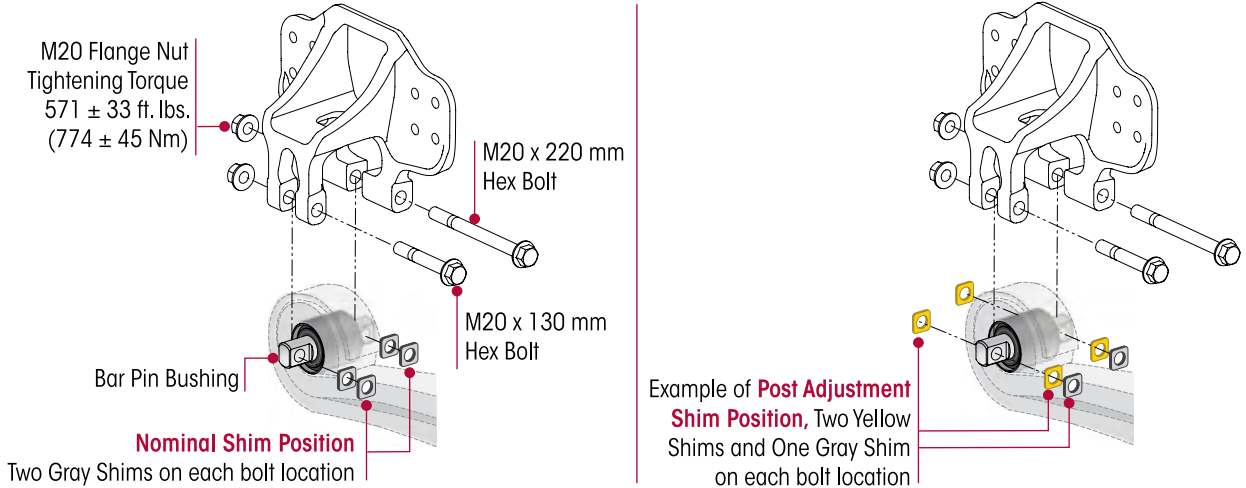

BAR PIN ALIGNMENT SHIMS

Hendrickson supplies alignment shims in 3/16" (4.8 mm) and 3/32" (2.4 mm) thicknesses for alignment adjustment, see Figure 7-8. A thinner 3/32" shim service kit (No. 78326-020) is available, refer to OEM specific ROADMAX Parts List online at www.hendrickson-intl.com.

FIGURE 7-8
Gray Shim

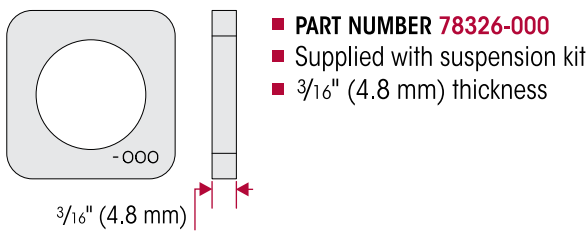

Yellow Shim

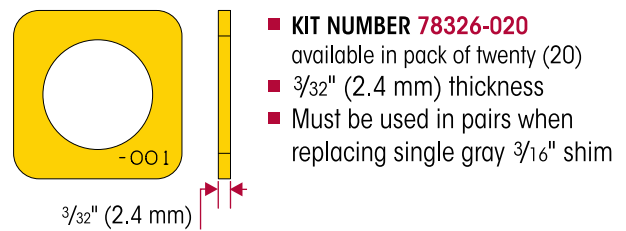

BAR PIN ALIGNMENT ADJUSTMENT

NOTE

Computerized alignment equipment is the preferred method of measuring alignment. To calculate the shim thickness required the target offset must be converted to thrust angle, see alignment equipment manufacturer for procedures.

If alignment of the drive axle is required, as determined by an alignment inspection procedure, the following steps will need to be performed.

1. Determine direction of axle thrust angle. Figure 7-9 illustrates the drive axle with a thrust angle to the left (-negative thrust). Axle movement is in the opposite direction of the increased shim thickness, see Figures 7-10 and 7-11.
2. To determine where to adjust shim thickness use measurement **A** and **B**, see Figure 7-6.

FIGURE 7-9

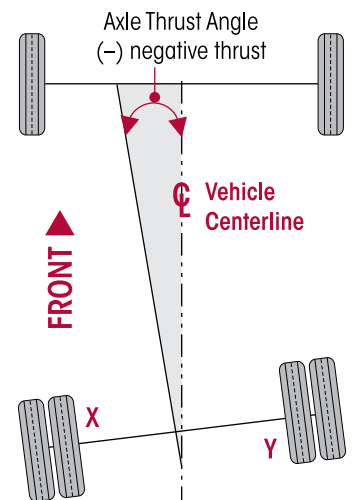

SERVICE HINT

Axle adjustment will be on the side of the bar pin where shim thickness is increased. **Example:** To correct the axle thrust angle illustrated in Figure 7-9, increase the shim thickness at the **back** of the bar pin (Location **X**) and/or the **front** of the bar pin (Location **Y**).

3. Chock the wheels to prevent vehicle movement during service.



4. Raise the frame of the vehicle to remove the load from the suspension. Support the frame at this height.
5. Support the main support member.
6. Remove and discard bar pin fasteners on the wheel end where the bar pin alignment shim adjustment is necessary.
7. Install shims to move the axle in the desired direction using a minimum of $\frac{3}{32}$ " (2.4 mm) increments for adjustment, see Figure 7-11.
8. Install new bar pin bushing fasteners and tighten to $\square 325 \pm 25$ foot pounds then alternate between lock-nuts until the final torque of $\square 571 \pm 33$ foot pounds is achieved, see Figure 7-7.
9. Remove support and lower the vehicle.
10. Verify the axles' alignments are within the vehicle manufactures tolerance.
11. Set brakes and remove wheel chocks.

FIGURE 7-10

NOMINAL BAR PIN POSITION

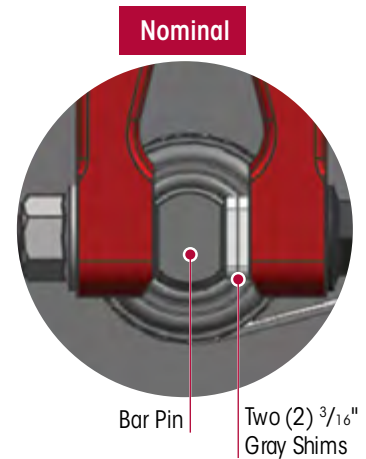

FIGURE 7-11

BAR PIN ALIGNMENT ADJUSTMENT



SECTION 8

Component Replacement

FASTENERS

Hendrickson recommends when servicing the vehicle, replace all removed fasteners with new equivalent fasteners. Maintain correct torque values at all times. Check torque values as specified. See Hendrickson's Torque Specifications Section in this publication. If non-Hendrickson fasteners are used follow torque specifications listed in the vehicle manufacturer's service manual.

HEIGHT CONTROL VALVE • LINKAGE ASSEMBLY

(If supplied by Hendrickson)

NOTE

If the height control valve is not supplied by Hendrickson, refer to the vehicle manufacturer's instructions for inspection, maintenance and rebuild instructions.

DISASSEMBLY

1. Chock the wheels of the vehicle.

WARNING

VEHICLE MUST BE FIRMLY SUPPORTED WITH JACK STANDS PRIOR TO SERVICING. FAILURE TO DO SO CAN RESULT IN PERSONAL INJURY OR PROPERTY DAMAGE.

2. Remove the height control valve's linkage assembly from the height control valve arm and lower mounting bracket by sliding the rubber grommets off their studs.

WARNING

PRIOR TO AND DURING DEFLATION AND INFLATION OF THE AIR SUSPENSION SYSTEM, ENSURE THAT ALL PERSONNEL AND EQUIPMENT ARE CLEAR FROM UNDER THE VEHICLE AND AROUND THE SERVICE AREA, FAILURE TO DO SO CAN CAUSE SERIOUS PERSONAL INJURY, DEATH, OR PROPERTY DAMAGE.

3. See additional Air Spring Cautions and Warnings in the Important Safety Notice Section of this publication prior to deflating or inflating the air system.
4. Lower the height control valve arm to exhaust the air in the air springs and deflate the rear suspension.
5. Remove the $\frac{5}{16}$ " fasteners that attach the linkage assembly to the height control valve lower bracket.
6. Remove the air fittings from the height control valve.
7. Remove the $\frac{1}{4}$ " fasteners that attach the height control valve to the frame mounting bracket.
8. Remove the height control valve, see Figure 8-1.

FIGURE 8-1

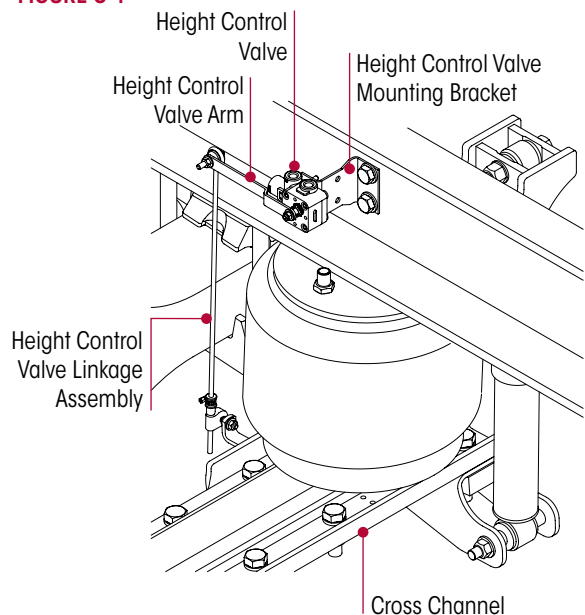
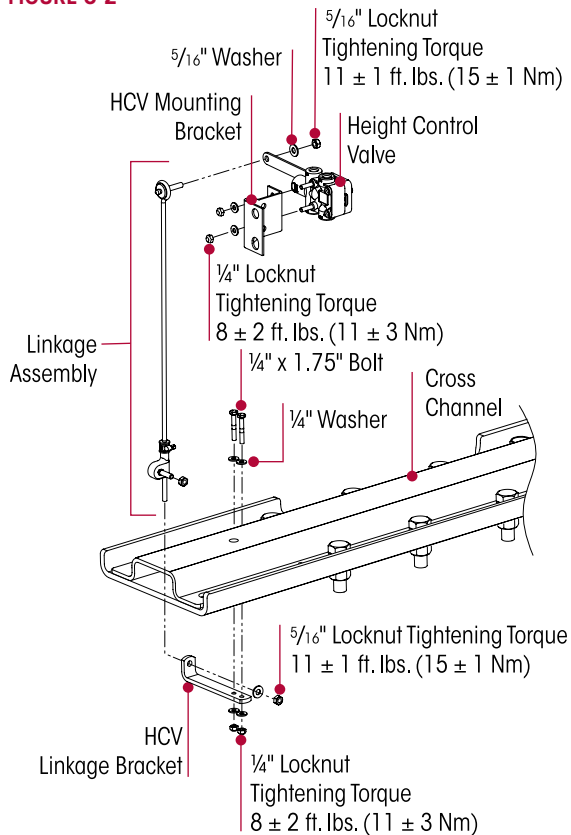

FIGURE 8-2

**ASSEMBLY**

1. Install the height control valve to the frame mounting bracket by attaching the $\frac{1}{4}$ " Fasteners. Tighten to 8 ± 2 foot pounds torque, see Figure 8-2.
2. Install the linkage assembly to the height control valve arm by attaching the $\frac{5}{16}$ " washer and locknut. Tighten to 11 ± 1 foot pounds torque, see Figure 8-2.
3. Install the height control valve linkage bracket to the cross channel by attaching the $\frac{1}{4}$ " fasteners. Tighten to 8 ± 2 foot pounds torque, see Figure 8-2.
4. Install the air lines to the height control valve. Refer to the Plumbing Diagram Section of this publication.
5. See additional Air Spring Cautions and Warnings in the Important Safety Notice Section of this publication prior to deflating or inflating the air system.
6. Inflate the suspension by connecting the height control valve linkage to the height control valve arm. Verify the air springs inflate uniformly without binding.
7. Remove the wheel chocks.
8. Verify the vehicle's ride height is within specifications, adjust as necessary, see Ride Height Adjustment in Alignment & Adjustments Section of this publication.

SERVICE HINT

If equipped with dual height control valves, follow the procedure on the other side.

AIR SPRING**DISASSEMBLY**

1. Chock the front wheels.
2. Raise and support the frame of the vehicle at ride height.

WARNING

THE VEHICLE MUST BE FIRMLY SUPPORTED WITH JACK STANDS PRIOR TO SERVICING. FAILURE TO DO SO CAN RESULT IN PERSONAL INJURY OR PROPERTY DAMAGE.

3. Disconnect the height control linkage assembly from the height control valve arm by sliding the rubber grommet from the stud.

WARNING

PRIOR TO AND DURING DEFLATION AND INFLATION OF THE AIR SUSPENSION SYSTEM, ENSURE THAT ALL PERSONNEL AND EQUIPMENT ARE CLEAR FROM UNDER THE VEHICLE AND AROUND THE SERVICE AREA, FAILURE TO DO SO CAN CAUSE SERIOUS PERSONAL INJURY, DEATH, OR PROPERTY DAMAGE.

4. See additional Air Spring Cautions and Warnings in the Important Safety Notice Section of this publication prior to deflating or inflating the air system.
5. Lower the height control valve arm to exhaust the air in the air springs and deflate the rear suspension.
6. Remove the air line from the air spring.
7. Remove air fittings from air spring.
8. Remove the M12 lower air spring fasteners that connect air spring to the cross channel, see Figure 8-3.

9. Remove the M16 fasteners that connect upper air spring bracket to the frame, see Figure 8-3.
10. Remove the air spring.

INSPECTION

1. Inspect the mounting surfaces and lower air spring mount for any damage. Replace as necessary.
2. Inspect upper air spring bracket for cracks. Replace as necessary.

ASSEMBLY

1. Install the air spring between the frame and cross channel, see Figure 8-3.
2. Install the air spring lower mounting stud through the cross channel hole. Attach the M12 fasteners to the lower mounting stud of the air spring. **USING HAND TOOLS ONLY**, tighten the locknut to 25 ± 5 foot pounds torque, see Figure 8-4.

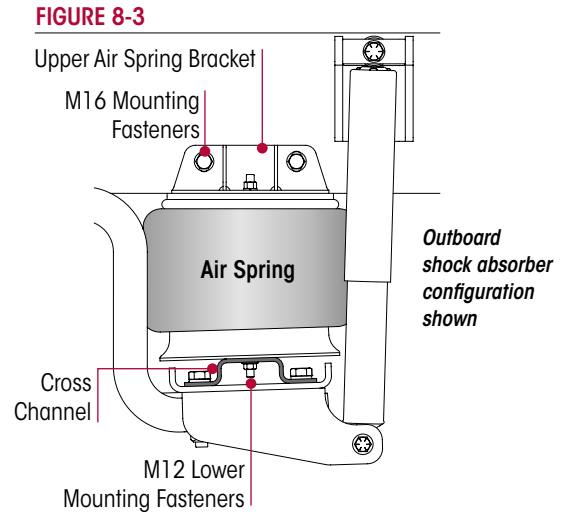

3. Install the air spring assembly to the frame. Attach the M16 fasteners and tighten to vehicle manufacturer's torque specifications.

CAUTION

FAILURE TO PRESS THE AIR SPRING AGAINST THE UNDERSIDE OF THE FRAME WHILE TIGHTENING THE UPPER AIR SPRING BRACKET CAN RESULT IN COMPONENT DAMAGE AND PERSONAL INJURY OR PROPERTY DAMAGE.

4. Connect the air line to the air spring.
5. See additional Air Spring Cautions and Warnings in the Important Safety Notice Section of this publication prior to deflating or inflating the air system.
6. Inflate the suspension by connecting the height control valve linkage to the height control valve arm. Verify the air springs inflate uniformly without binding.
7. Remove the frame supports.
8. Remove the wheel chocks.
9. Verify the vehicle's ride height is within specifications. Adjust as necessary, see Ride Height Adjustment in Alignment & Adjustments Section of this publication.

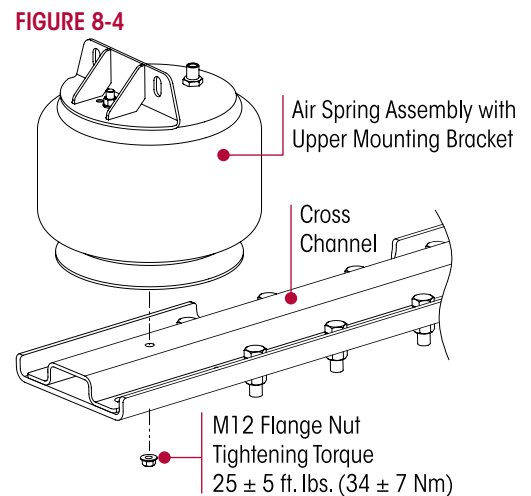

SHOCK ABSORBER

NOTE

It is not necessary to replace shock absorbers in pairs if only one (1) shock absorber requires replacement.

DISASSEMBLY

1. Chock the wheels of the vehicle.
2. Remove the $\frac{3}{4}$ " fasteners, that connect shock absorber to frame hanger, see Figure 8-5.
3. Remove the $\frac{5}{8}$ " fasteners that connect shock absorber to lower shock bracket, see Figure 8-5.
4. Slide the shock absorber out of the lower mounting bracket.
5. Remove the shock absorber from the upper mounting bracket.
6. Inspect the shock absorber mounting brackets and hardware for damage or wear, and replace as necessary, see the Preventive Maintenance Section of this publication.

FIGURE 8-5

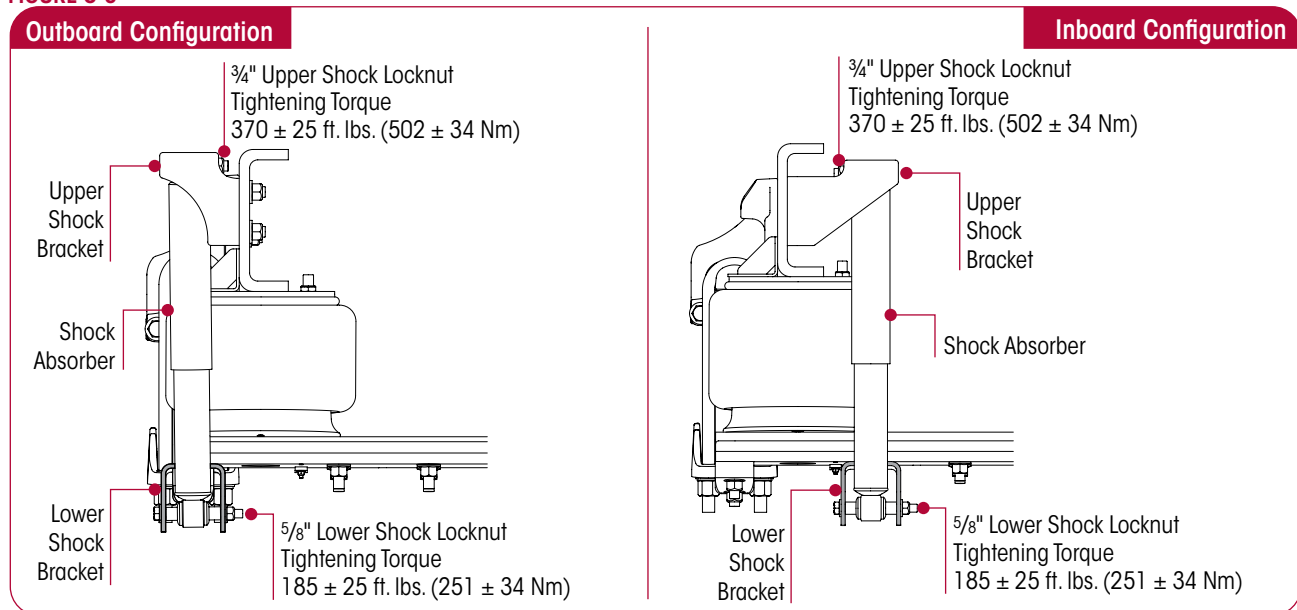

ASSEMBLY

1. Install shock absorber to upper mounting bracket by attaching $\frac{3}{4}$ " fasteners.
2. Install shock absorber to lower shock bracket by attaching the $\frac{5}{8}$ " fasteners.
3. Tighten lower $\frac{5}{8}$ " locknut to 185 ± 25 foot pounds torque.
4. Tighten upper $\frac{3}{4}$ " locknut to 370 ± 25 foot pounds torque, see Figure 8-5.
5. Remove the frame supports.
6. Remove the wheel chocks.
7. Verify the vehicle's ride height is within specifications. Adjust as necessary, see Ride Height Adjustment in Alignment & Adjustments Section of this publication.



SHOCK ABSORBER LOWER MOUNTING BRACKET

DISASSEMBLY

1. Chock the front wheels.
2. Raise and support the frame of the vehicle at ride height.

WARNING

THE VEHICLE MUST BE FIRMLY SUPPORTED WITH JACK STANDS PRIOR TO SERVICING. FAILURE TO DO SO CAN RESULT IN PERSONAL INJURY OR PROPERTY DAMAGE.

3. Disconnect the height control linkage assembly from the height control valve arm by sliding the rubber grommet from the stud.

WARNING

PRIOR TO AND DURING DEFLATION AND INFLATION OF THE AIR SUSPENSION SYSTEM, ENSURE THAT ALL PERSONNEL AND EQUIPMENT ARE CLEAR FROM UNDER THE VEHICLE AND AROUND THE SERVICE AREA, FAILURE TO DO SO CAN CAUSE SERIOUS PERSONAL INJURY, DEATH, OR PROPERTY DAMAGE.

4. See additional Air Spring Cautions and Warnings in the Important Safety Notice Section of this publication prior to deflating or inflating the air system.
5. Lower the height control valve arm to exhaust the air in the air springs and deflate the rear suspension.
6. Remove the air lines from the air springs.
7. Remove the $\frac{3}{4}$ " fasteners that connect the shock absorber to the upper frame bracket.
8. Remove the $\frac{5}{8}$ " fasteners that connect the shock absorber to outboard or inboard (as equipped) lower shock bracket, see Figure 8-6.
9. Slide the shock absorber out of the lower mounting bracket.
10. Remove the M20 fasteners that connect the cross channel and lower shock bracket to the main support member assembly on the affected side. Loosen the M20 bolts, washers and locknuts on the opposite side.
11. Using a floor jack under the center of the cross channel, raise the cross channel slightly.
12. Remove lower shock bracket.

INSPECTION

1. Inspect the shock absorber mounting brackets for damage or wear, and replace as necessary, see the Preventive Maintenance Section of this publication.

ASSEMBLY

1. Install the lower shock absorber mounting bracket to the main support member.
2. Lower the cross channel on top of the main support member and the lower shock absorber mounting bracket for outboard or inboard shock absorber as shown in Figure 8-6.
3. Loosely install the two M20 bolts through the cross channel holes, lower shock bracket and main support member on each end of the cross channel, see Figure 8-6.
4. Tighten the M20 fasteners, see Figure 8-6
 - Outboard lower shock bracket to $\boxed{445} \pm 25$ foot pounds torque
 - Inboard lower shock bracket to $\boxed{380} \pm 25$ foot pounds torque
5. Slide the shock absorber lower mount into the lower shock absorber mounting bracket.
6. Install the $\frac{5}{8}$ " fasteners through the lower shock absorber mount and lower shock bracket. Tighten the fasteners to $\boxed{185} \pm 25$ foot pounds torque, see Figure 8-6.
7. Install the upper $\frac{3}{4}$ " fasteners and tighten to $\boxed{370} \pm 25$ foot pounds torque, see Figure 8-6.
8. Reconnect the air lines to the air springs.
9. See additional Air Spring Cautions and Warnings in the Important Safety Notice Section of this publication prior to deflating or inflating the air system.

10. Inflate the suspension by connecting the height control valve linkage to the height control valve arm. Verify the air springs inflate uniformly without binding.
11. Remove the frame supports.
12. Remove the wheel chocks.
13. Verify the vehicle's ride height is within specifications. Adjust as necessary, see Ride Height Adjustment in Alignment & Adjustments Section in this publication.

FIGURE 8-6

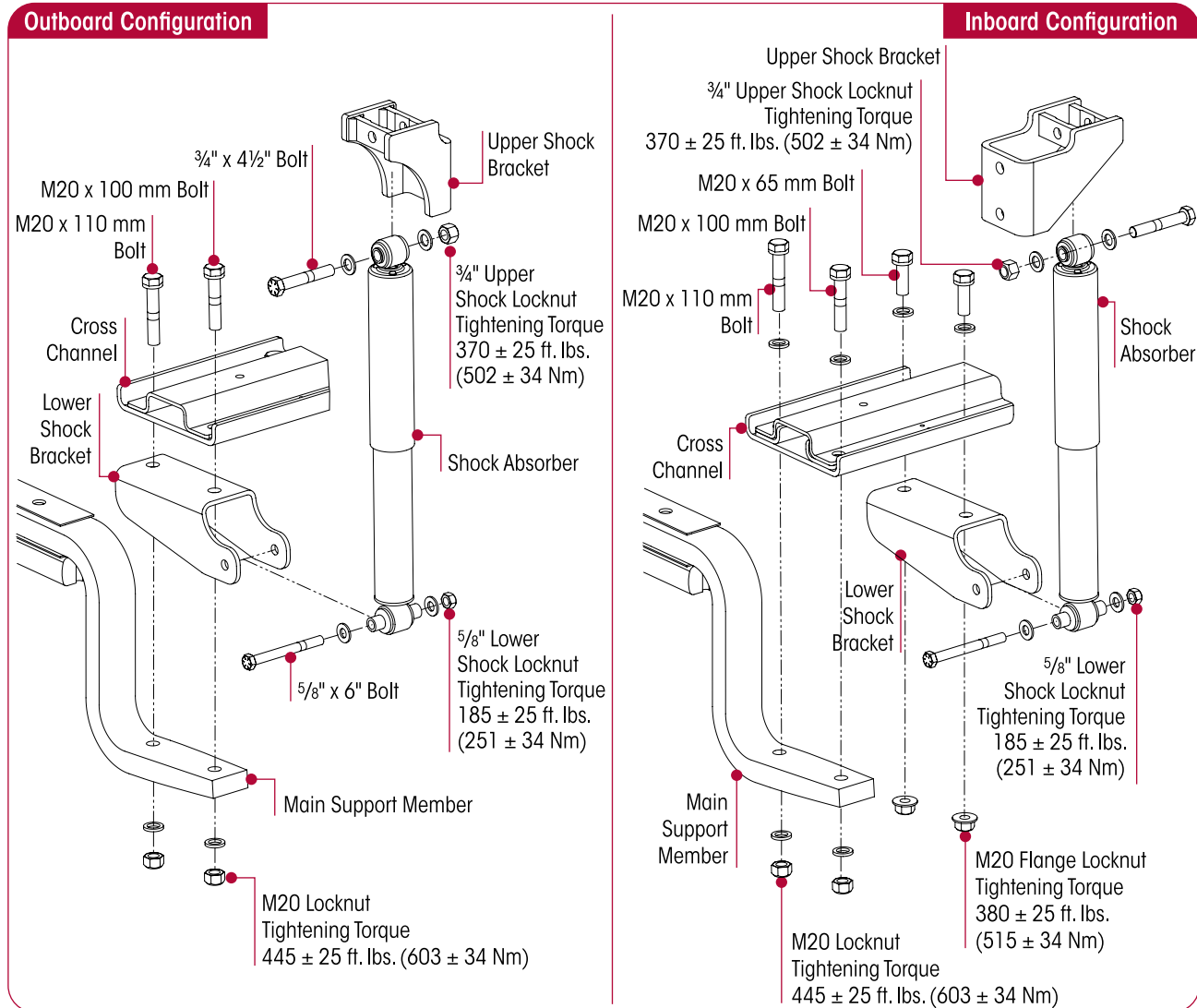

CROSS CHANNEL

DISASSEMBLY

1. Chock the front wheels.
2. Support the frame of the vehicle at ride height.

WARNING

THE VEHICLE MUST BE FIRMLY SUPPORTED WITH JACK STANDS PRIOR TO SERVICING. FAILURE TO DO SO CAN RESULT IN PERSONAL INJURY OR PROPERTY DAMAGE.

3. Remove the air springs as detailed in the Air Spring Disassembly in this section.
4. Remove the $\frac{1}{4}$ " fasteners that connects height control valve linkage bracket to cross channel. Remove the bracket.



5. Remove the four outer M20 bolts (from the cross channel to main support member, see Figure 8-7).
6. Remove the cross channel.

INSPECTION

1. Inspect the mounting surfaces and lower air spring mount for any damage. Replace as necessary.
2. Inspect the upper air spring bracket for cracks. Replace as necessary.
3. Inspect the cross channel for straightness, excessive wear and cracks. Replace as necessary.

ASSEMBLY

1. Place cross channel on top of the lower shock bracket and main support member.
2. Loosely install the two M20 bolt and washer through the cross channel holes, lower shock bracket and main support member on each end of the cross channel, see Figure 8-7.
3. Tighten the cross channel fasteners to \mathbb{R} 445 ± 25 foot pounds torque, see Figure 8-7.

FIGURE 8-7

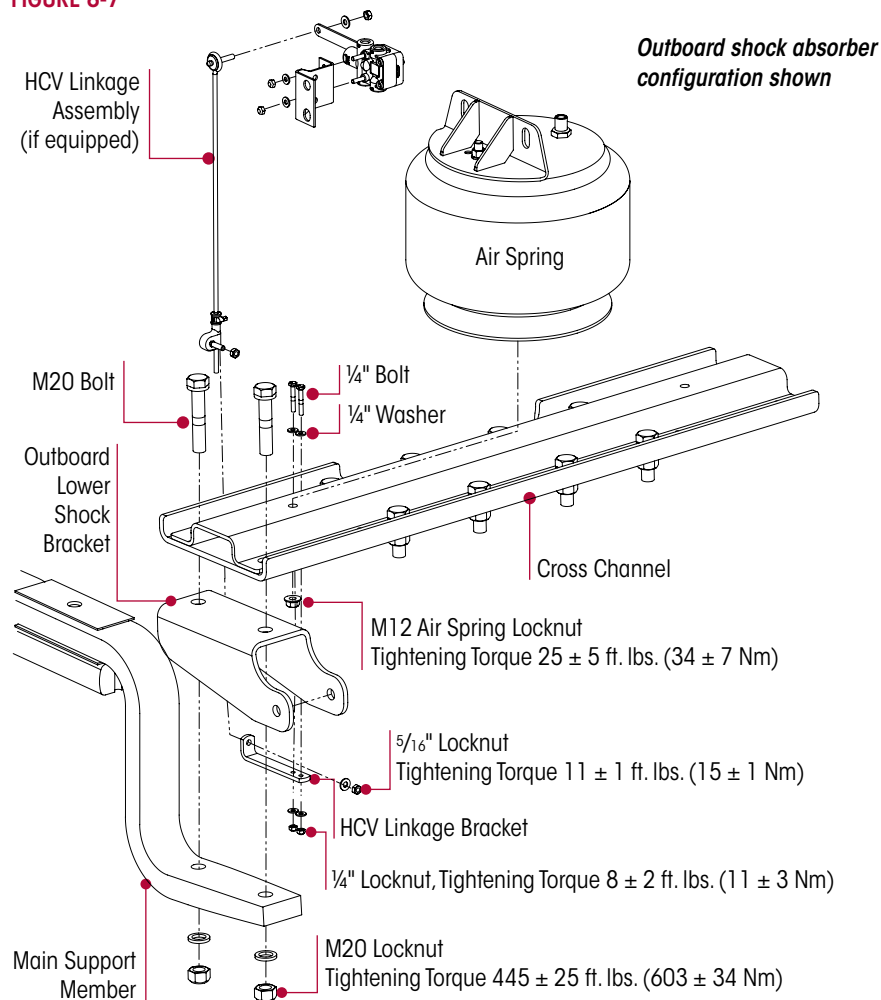

4. Install the height control valve lower bracket to the cross channel using two 1/4" fasteners. Tighten the fasteners to \mathbb{R} 8 ± 2 foot pounds torque.
5. Install the air spring between the frame and cross channel.

6. Install the air spring lower mounting stud through the cross channel hole. Attach the M12 fasteners to the lower mounting stud of the air spring. **USING HAND TOOLS ONLY**, tighten the flange nut to  25 ± 5 foot pounds torque.
7. Install the air spring assembly to the frame. Attach the M16 fasteners and tighten to vehicle manufacturer's torque specifications.

CAUTION

FAILURE TO PRESS THE AIR SPRING AGAINST THE UNDERSIDE OF THE FRAME WHILE TIGHTENING THE UPPER AIR SPRING BRACKET CAN RESULT IN COMPONENT DAMAGE AND PERSONAL INJURY OR PROPERTY DAMAGE.

8. Connect the air line to the air spring.
9. See additional Air Spring Cautions and Warnings in the Important Safety Notice Section of this publication prior to deflating or inflating the air system.
10. Inflate the suspension by connecting the height control valve linkage to the height control valve arm. Verify the air springs inflate uniformly without binding.
11. Remove the frame supports.
12. Remove the wheel chocks.
13. Verify the vehicle's ride height is within specifications, adjust as necessary, see Ride Height Adjustment in Alignment & Adjustments Section of this publication.

CLAMP GROUP

- TOP PAD
- SPACER
- SPRING SEAT
- BOTTOM CAP

WARNING

THE PROCEDURE TO DISASSEMBLE THE CLAMP GROUP IS DONE WITH THE OTHER MAIN SUPPORT MEMBER PROPERLY CONNECTED TO THE FRAME HANGER AND AXLE. FAILURE TO HAVE THE OTHER MAIN SUPPORT MEMBER CONNECTED PROPERLY COULD ALLOW THE AXLE TO SHIFT RESULTING IN POSSIBLE DAMAGE TO COMPONENTS AND/OR PERSONAL INJURY. IF THE OTHER MAIN SUPPORT MEMBER ISN'T PROPERLY CONNECTED TO THE FRAME HANGER AND AXLE IT WILL BE NECESSARY TO SUPPORT THE AXLE PINION TO KEEP THE AXLE FROM SHIFTING.

DISASSEMBLY

1. Chock the front wheels.
2. Support the frame of the vehicle at ride height.

WARNING

THE VEHICLE MUST BE FIRMLY SUPPORTED WITH JACK STANDS PRIOR TO SERVICING. FAILURE TO DO SO CAN RESULT IN PERSONAL INJURY OR PROPERTY DAMAGE.

3. Disconnect the height control linkage assembly from the height control valve arm by sliding the rubber grommet from the stud.

WARNING

PRIOR TO AND DURING DEFLATION AND INFLATION OF THE AIR SUSPENSION SYSTEM, ENSURE THAT ALL PERSONNEL AND EQUIPMENT ARE CLEAR FROM UNDER THE VEHICLE AND AROUND THE SERVICE AREA, FAILURE TO DO SO CAN CAUSE SERIOUS PERSONAL INJURY, DEATH, OR PROPERTY DAMAGE.

4. See additional Air Spring Cautions and Warnings in the Important Safety Notice Section of this publication prior to deflating or inflating the air system.
5. Lower the height control valve arm to exhaust the air in the air springs and deflate the rear suspension.
6. On the side being serviced, remove and discard the U-bolts, hex nuts and washers, see Figure 7-8.
7. Remove the bottom cap and top pad.



- Remove fasteners from cross channel on the opposite side from the side being serviced.

SERVICE HINT

Removing the cross channel bolts from the opposite side allows accessibility to the clamp group being serviced without removing the main support member and the air spring.

FIGURE 8-8

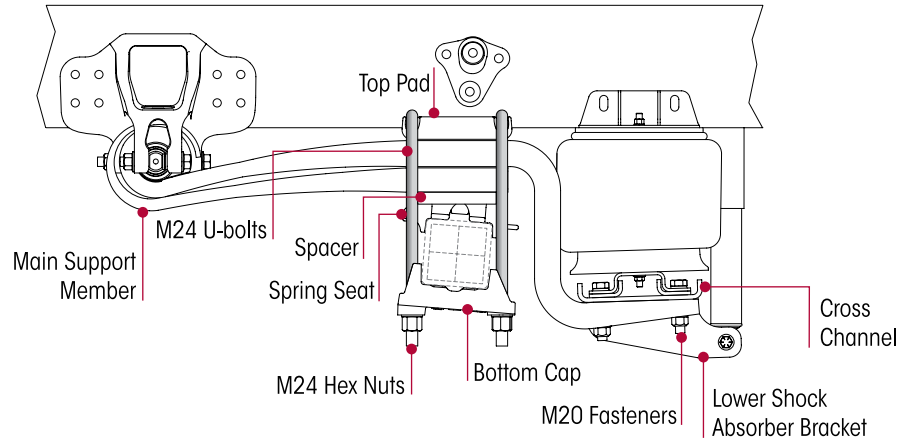

- Place a floor jack under the cross channel near the main support member being serviced. Raise the cross channel and main support member enough to remove the spring seat from under the main support member.

INSPECTION



WARNING

FAILURE OF THE MAIN SUPPORT MEMBER WILL REQUIRE THE REPLACEMENT OF THE MAIN SUPPORT MEMBER AND ALL CLAMP GROUP COMPONENTS. FAILURE TO DO SO CAN RESULT IN CLAMP GROUP FAILURE AND FURTHER FAILURE TO THE MAIN SUPPORT MEMBER, WHICH CAN CAUSE ADVERSE VEHICLE HANDLING, PROPERTY DAMAGE OR SEVERE PERSONAL INJURY.

- Inspect the main support member assembly for damage. Replace as necessary.
- Inspect the top pad, spring seat and bottom cap for excessive wear and cracks or fretting. Replace as necessary.
- Inspect the axle housing for any cracks or wear. Repair or replace as necessary.

ASSEMBLY

- Install the spring seat on the axle housing making sure to engage the alignment locator on the axle housing with the hole in the bottom of the spring seat. Verify the thicker end of the spring seat is to the rear of the vehicle.

FIGURE 8-9

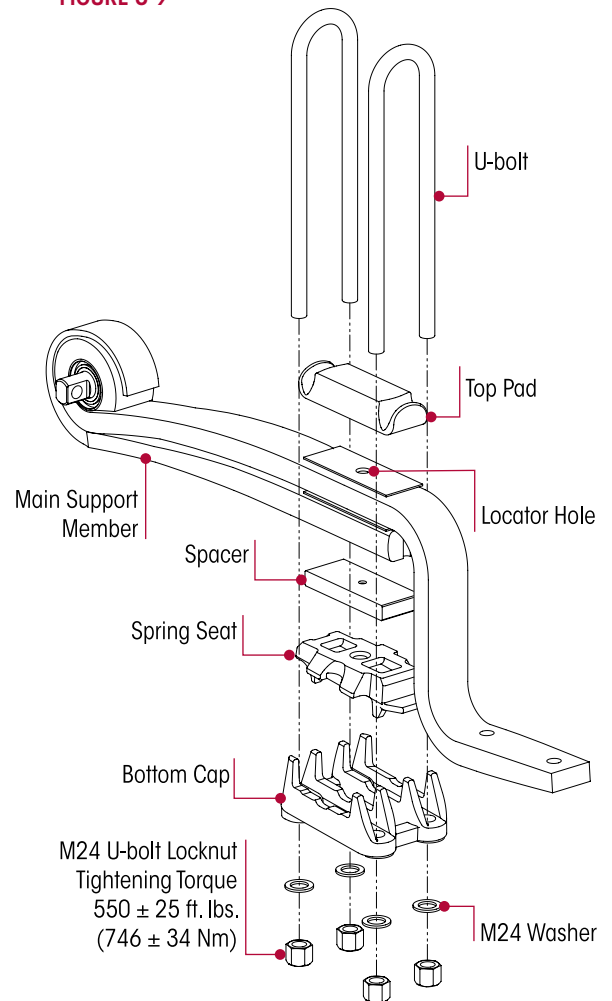

2. Lower the main support member assembly on the spring seat. Ensure the locator hole on the bottom of the main support member engages spring seat locator holes.
3. Install top pad on the top of the main support member assembly. Ensure the locator hole on the bottom of the top pad engages the main support member locator holes.

WARNING

U-BOLTS THAT ARE FOUND TO BE LOOSE REQUIRE THAT MATING COMPONENTS BE INSPECTED FOR SIGNS OF WEAR OR FRETTING. ANY COMPONENTS WORN MUST BE REPLACED. FAILURE TO DO SO CAN CAUSE PREMATURE CLAMP GROUP FAILURE, COMPONENT DAMAGE, ADVERSE VEHICLE HANDLING, PROPERTY DAMAGE, OR SEVERE PERSONAL INJURY. MAINTAIN CORRECT TORQUE VALUE AT ALL TIMES. CHECK TORQUE VALUES ON A REGULAR BASIS AS SPECIFIED.

4. Install **NEW** U-bolts, flat washers, and hex nuts.
5. Verify that the top pad, spacer and bottom cap are installed correctly.
6. Lower the cross channel onto the opposite side lower shock bracket and main support member. Install the two M20 bolt and washers through the cross channel, lower shock bracket and main support member. Loosely install the M20 locknuts and washers. **DO NOT** tighten at this time.

WARNING

IT IS IMPORTANT THAT THE U-BOLT CLAMP GROUP CONNECTION BE PROPERLY ALIGNED AND HAVE THE PROPER TIGHTENING TORQUE VALUES MAINTAINED. METAL SURFACES CAN WORK AND WEAR AGAINST OTHER RELATED CLAMP GROUP COMPONENTS IF NOT PROPERLY ALIGNED OR PROPERLY TIGHTENED TO MAINTAIN THE PROPER CLAMP FORCE. FAILURE TO DO SO CAN CAUSE PREMATURE COMPONENT WEAR, POSSIBLE SEPARATION OF THE CLAMP GROUP, CAUSING ADVERSE VEHICLE HANDLING, PROPERTY DAMAGE, OR PERSONAL INJURY.

7. Verify that the U-bolts are seated properly in the channels of the top pad, see Figure 8-9.
8. Verify the main support member is centered in the frame hanger.
9. Snug U-bolts (approximately $\boxed{100}$ foot pounds) prior to tightening, applying a crisscross pattern, see Figure 8-10.
10. Tighten the M20 cross channel fasteners to $\boxed{445 \pm 25}$ foot pounds torque.
11. Tighten the U-bolt hex nuts in the proper sequence, shown in Figure 8-10, evenly in 50 foot pounds increments to achieve uniform bolt tension to $\boxed{550 \pm 25}$ foot pounds torque, see Figure 8-9.
12. Rap the top of the U-bolts with a dead blow mallet and retighten to specified torque. **DO NOT** exceed specified torque on U-bolt hex nuts.
13. See additional Air Spring Cautions and Warnings in the Important Safety Notice Section of this publication prior to deflating or inflating the air system.
14. Inflate the suspension by connecting the height control valve linkage to the height control valve arm. Verify the air springs inflate uniformly without binding.
15. Remove the frame supports.
16. Remove the wheel chocks.
17. Verify the vehicle's ride height is within specifications. Adjust as necessary, see Ride Height Adjustment in Alignment & Adjustments Section of this publication.
18. Align the vehicle. Alignment is necessary anytime the main support member is removed to complete the repair, see Alignment & Adjustments Section of this publication.

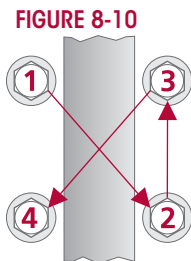



MAIN SUPPORT MEMBER

CAUTION

THIS PROCEDURE TO REPLACE A MAIN SUPPORT MEMBER IS DONE WITH THE OTHER MAIN SUPPORT MEMBER PROPERLY CONNECTED TO THE FRAME HANGER AND AXLE. FAILURE TO HAVE THE OTHER MAIN SUPPORT MEMBER CONNECTED PROPERLY COULD ALLOW THE AXLE TO SHIFT RESULTING IN POSSIBLE DAMAGE TO COMPONENTS AND/OR PERSONAL INJURY. IF BOTH MAIN SUPPORT MEMBERS ARE TO BE REMOVED IT WILL BE NECESSARY TO SUPPORT THE AXLE PINION TO KEEP THE AXLE FROM SHIFTING.

DISASSEMBLY

1. Chock the front wheels.
2. Support the frame of the vehicle at ride height.

WARNING

THE VEHICLE MUST BE FIRMLY SUPPORTED WITH JACK STANDS PRIOR TO SERVICING. FAILURE TO DO SO CAN RESULT IN PERSONAL INJURY OR PROPERTY DAMAGE.

3. Remove the height control valve's linkage assembly from the height control valve arm and lower mounting bracket by sliding the rubber grommets off their studs.
4. Remove the air spring(s) per the Air Spring Disassembly instructions in this section.
5. On the side being serviced, remove and discard the U-bolts locknuts and washers.
6. Remove the top pad, spring seat, spacer and bottom cap.
7. Support the main support member by placing a hydraulic jack under the spring eye bushing.
8. Remove the M20 spring eye fasteners, see Figure 8-11.
9. Slide the spring eye bushing down and out of the frame hanger. Remove the main support assembly.

INSPECTION

WARNING

U-BOLTS THAT ARE FOUND TO BE LOOSE REQUIRE THAT MATING COMPONENTS BE INSPECTED FOR SIGNS OF WEAR OR FRETTING. ANY COMPONENTS WORN MUST BE REPLACED. FAILURE TO DO SO CAN CAUSE PREMATURE CLAMP GROUP FAILURE, COMPONENT DAMAGE, ADVERSE VEHICLE HANDLING, PROPERTY DAMAGE, OR SEVERE PERSONAL INJURY. MAINTAIN CORRECT TORQUE VALUE AT ALL TIMES. CHECK TORQUE VALUES ON A REGULAR BASIS AS SPECIFIED.

1. Inspect the frame hanger for excessive wear, cracks and proper frame hanger fastener torque. Replace as necessary.
2. Inspect the main support member for damage. Replace as necessary.
3. Inspect the top pad, spring seat and bottom cap for excessive wear and cracks or fretting. Replace as necessary.
4. Inspect the axle housing for any cracks or wear. Repair or replace as necessary.
5. Inspect the air spring for damage and inspect the lower piston and the upper air spring mount for cracks. Replace as necessary.

ASSEMBLY

WARNING

DO NOT STRIKE SUSPENSION COMPONENTS WITH A HAMMER. DO NOT NICK OR GOUGE THE MAIN SUPPORT MEMBER. SUCH IMPROPER ACTIONS CAN CAUSE DAMAGE; THE MAIN SUPPORT MEMBER ASSEMBLY COULD FAIL, AND CAUSE ADVERSE VEHICLE HANDLING AND POSSIBLE PERSONAL INJURY OR PROPERTY DAMAGE.

1. Position the main support member assembly on spring seat and spacer with the main support member assembly center locator piloting into hole in spring seat.

NOTE

Galvanized steel liner must be positioned on the topside of the 2-leaf main support member assembly.

FIGURE 8-11

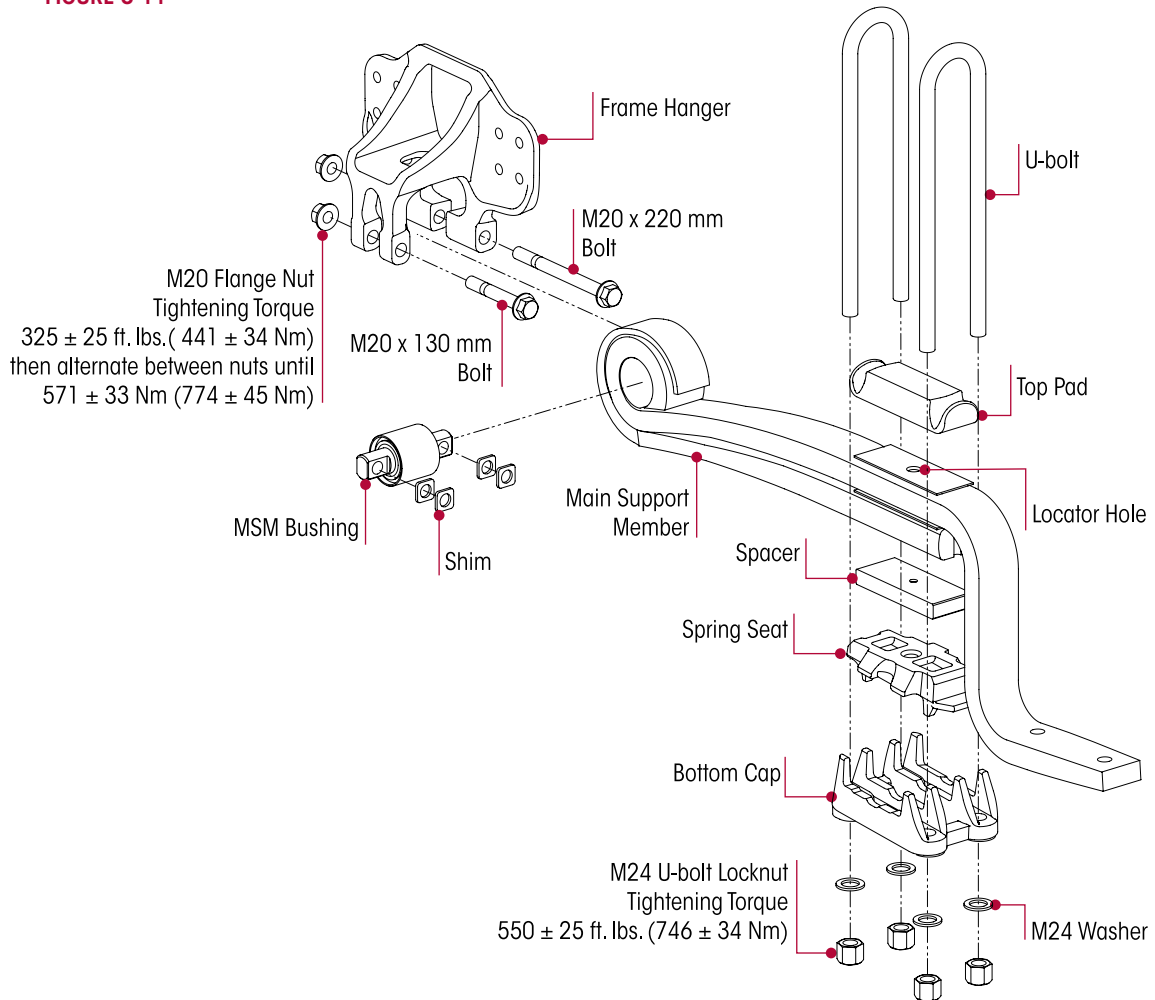

2. Align the bushing of the main support member assembly under the opening of the frame hanger and jack into place.
3. Loosely install M20 frame hanger bolts.
4. Raise the rear of the main support member assembly and install the spring seat on the axle, engaging the locator holes.
5. Lower the main support member assembly onto the spring seat. Ensure the locator engages the locator hole in the spring seat.
6. Install the top pad, spacer, bottom cap, U-bolts, washers, and hex nuts. Ensure all locators are engaged. Verify that the top pad and bottom cap are installed correctly, see Figure 8-11.
7. Verify that the U-bolts are seated properly in the channels of the top pad, see Figure 8-11.
8. Snug U-bolts in a crisscross pattern, see Figure 8-10, **DO NOT** tighten at this time.
9. Install the shock absorber and the lower shock bracket onto the rear of the main support member assembly, see Figure 8-13.
10. Install the cross channel onto the rear of the main support member assemblies. Loosely install the cross channel retaining fasteners, see Figure 8-13.

FIGURE 8-12

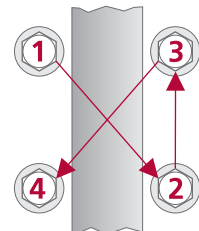
**SERVICE HINT**

It may be necessary to loosen the U-bolts in order to align the cross channel holes with the main support member assemblies. **DO NOT** strike suspension components with a hammer.

**NOTE**

Prior to tightening the frame hanger fasteners, U-bolts, or cross channel fasteners to specifications, it is mandatory that the vehicle be positioned at the proper ride height.

11. Tighten the M20 cross channel fasteners to \mathbb{N} 445 \pm 25 foot pounds torque, see Figure 8-13.

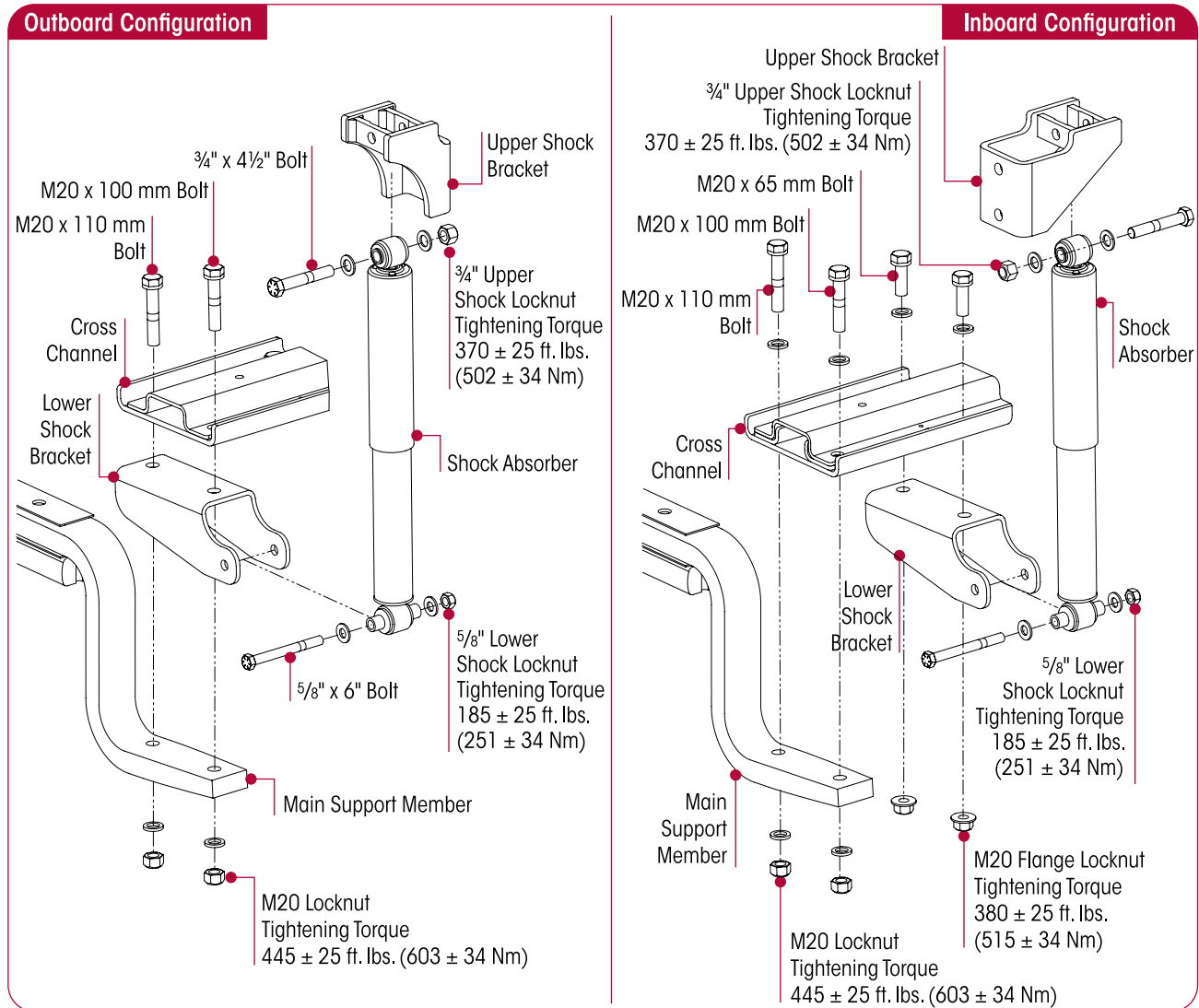
FIGURE 8-13

12. Tighten the U-bolt hex nuts in the proper sequence, shown in Figure 8-12, evenly in 50 foot pounds increments to achieve uniform bolt tension to \mathbb{N} 550 \pm 25 foot pounds torque, see Figure 8-11.

13. Rap the top of the U-bolts with a dead blow mallet and retighten to specified torque. **DO NOT EXCEED SPECIFIED TORQUE ON U-BOLT LOCKNUTS.**

14. Install the air spring lower mounting stud through the cross channel hole. Attach the M12 fasteners to the lower mounting stud of the air spring. **USING HAND TOOLS ONLY**, tighten the locknut to \mathbb{N} 25 \pm 5 foot pounds torque.

15. See additional Air Spring Cautions and Warnings in the Important Safety Notice Section of this publication prior to deflating or inflating the air system.

16. Inflate the suspension by connecting the height control valve linkage to the height control valve arm. Verify the air springs inflate uniformly without binding.

17. Remove the frame supports.

18. Remove the wheel chocks.

19. Verify the vehicle's ride height is within specifications. Adjust as necessary, see Ride Height Adjustment in Alignment & Adjustments Section of this publication.
20. Verify that the axle is in proper alignment, see the Alignment & Adjustments Section of this publication.
21. After the correct alignment of the axle is verified, tighten the frame hanger to main support member fasteners to \mathbb{N} 325 \pm 25 foot pounds, then alternate between nuts until it reaches to \mathbb{N} 571 \pm 33 foot pounds torque, see Figure 8-13.
22. Remove the wheel chocks.

MAIN SUPPORT MEMBER BUSHINGS

YOU WILL NEED:

- A hydraulic press with an minimum operating capacity of 5 tones.
- Main support member bushing Receiving and Driver tools, see specifications in the Special Tools Section of this publication.

DISASSEMBLY

1. Follow the procedure for the Main Support Member disassembly in this section.

WARNING

DO NOT USE HEAT OR A CUTTING TORCH TO REMOVE THE BUSHING FROM THE MAIN SUPPORT MEMBER. THE USE OF SUCH HEAT CAN ADVERSELY AFFECT THE STRENGTH OF THE MAIN SUPPORT MEMBER ASSEMBLY. A COMPONENT DAMAGED IN THIS MANNER CAN RESULT IN THE ADVERSE VEHICLE HANDLING AND POSSIBLE PERSONAL INJURY OR PROPERTY DAMAGE.

2. Support and center the main support member end hub on the receiving tool. The main support member must be level to distribute the vertical pushing load equally on the bushing.
3. Place the bushing driver centered on the main support member bushing, see Figures 8-14 and 8-15. Care must be taken to prevent damage to main support member.

FIGURE 8-14



FIGURE 8-15

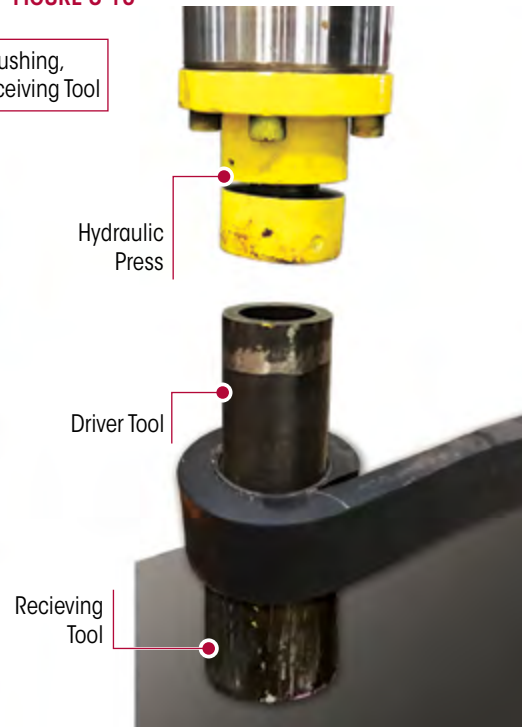

4. Press out the main support member bushing. Push directly on the bushing driver until the bushing clears the main support member bore.

INSPECTION

1. Inspect the inside surface of the main support member for any deep scratches, burrs or cracks. If cracks are present replacement of the main support member assembly is necessary.
2. Measure the inner diameter (I.D.) of the main support member bore. The specification for the main support member assembly bore inner diameter is $83.6 \text{ mm} \pm 0.2 \text{ mm}$, see Figure 8-16. If measurement is **NOT** within the specified range replacement of the main support member is required.
3. Ensure that the new bushing and main support member surface are free of grease, oil, or other contaminants prior to pressing in the new bushing.

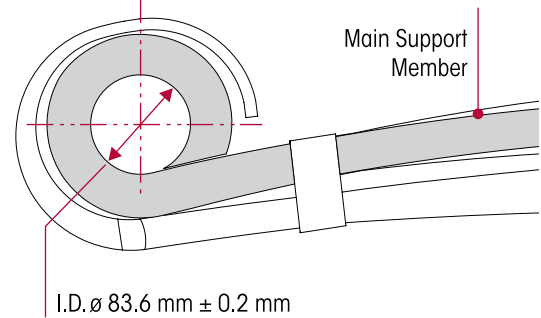
FIGURE 8-16

ASSEMBLY

1. Support and center the main support member end hub on the receiving tool. The steel main support member must be level to distribute the vertical pushing load equally on the bushing.
2. With a brush, apply Loctite 290 or equivalent **ONLY** to the outer surface of the main support member bushing that enters the main support member end hub first in the location specified in Figure 8-17. **DO NOT** apply Loctite 290 to the main support member eye bore.

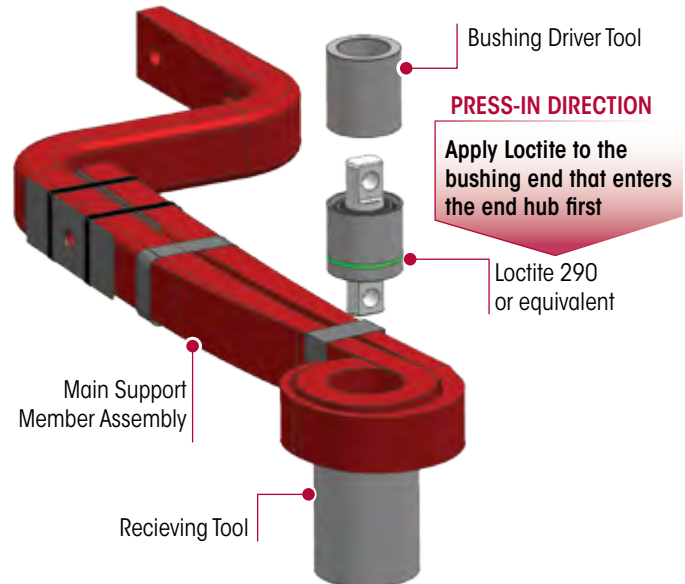
FIGURE 8-17

3. Install the bushing driver tool on the new main support member bushing.
4. Press the bushing in until it is centered in the main support member bore, with a dimension of $5.7 \text{ mm} \pm 0.9 \text{ mm}$ of the machined lip of the bar pin showing from the width of the main support member bore, see Figure 8-18.
5. Once the bushing is installed, follow the procedure for the Main Support Member in this section.

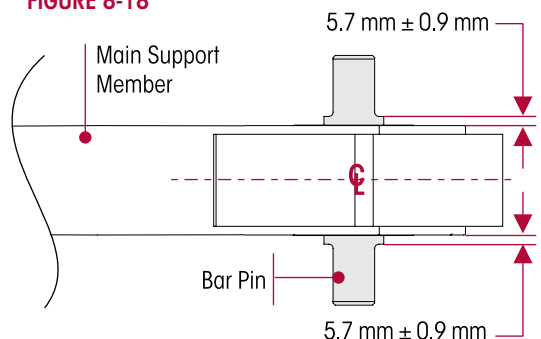
FIGURE 8-18

FRAME HANGER

The frame hanger should function satisfactorily during normal vehicle operation. Replacement is required when the frame hanger has been damaged or worn.

DISASSEMBLY

1. Chock the front wheels.
2. Raise and support the frame of the vehicle at ride height.

WARNING

THE VEHICLE MUST BE FIRMLY SUPPORTED WITH JACK STANDS PRIOR TO SERVICING. FAILURE TO DO SO CAN RESULT IN PERSONAL INJURY OR PROPERTY DAMAGE.

3. Disconnect the height control valve's linkage assembly from the height control valve arm by sliding the rubber grommet from the stud.

WARNING

PRIOR TO AND DURING DEFLATION AND INFLATION OF THE AIR SUSPENSION SYSTEM, ENSURE THAT ALL PERSONNEL AND EQUIPMENT ARE CLEAR FROM UNDER THE VEHICLE AND AROUND THE SERVICE AREA, FAILURE TO DO SO CAN CAUSE SERIOUS PERSONAL INJURY, DEATH, OR PROPERTY DAMAGE.

4. See additional Air Spring Cautions and Warnings in the Important Safety Notice Section of this publication prior to deflating or inflating the air system.
5. Lower the height control valve arm to exhaust the air in the air springs and deflate the rear suspension.
6. Remove the M20 fasteners that connect the main support member to the frame hanger, see Figure 7-19.
7. Remove the M16 fasteners that attach the frame hanger to the vehicle frame.
8. Remove the frame hanger.

INSPECTION

1. Inspect mounting surface of hanger and frame for any damage or wear. Repair or replace as necessary.
2. Inspect the main support member assembly and bushing for wear or damage. Replace as necessary.

FIGURE 8-19

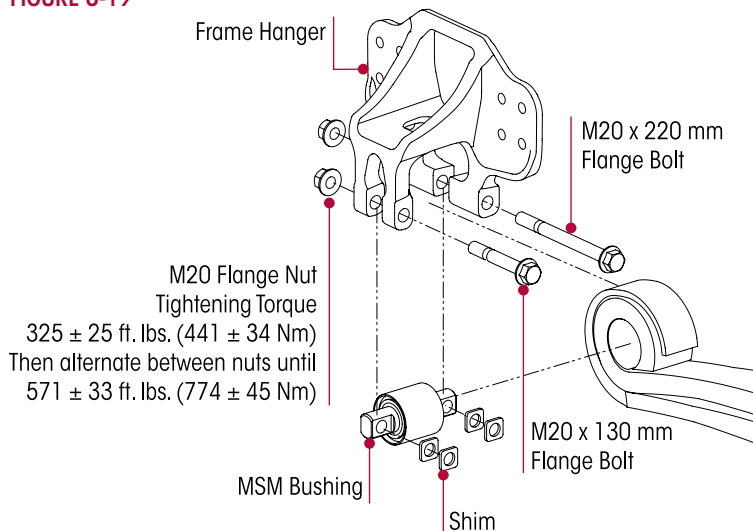

ASSEMBLY

1. Slide the frame hanger over the main support member's bushing.
2. Install new hanger to frame rail fasteners as detailed by the vehicle manufacturer.

NOTE

Prior to tightening the spring eye bolt to final torque specifications, it is mandatory that the vehicle be positioned at the proper ride height.

3. See additional Air Spring Cautions and Warnings in the Important Safety Notice Section of this publication prior to deflating or inflating the air system.
4. Inflate the suspension by connecting the height control valve linkage to the height control valve arm per the vehicle manufacturer's instructions. Verify the air springs inflate uniformly without binding.
5. Remove the frame supports.
6. Verify the vehicle's ride height is within specifications per the vehicle manufacturer.
7. After the ride height is verified, tighten the frame hanger to main support member fasteners to $\boxed{325 \pm 25}$ foot pounds, then alternate between nuts until it reaches to $\boxed{571 \pm 33}$ foot pounds torque, see Figure 8-19.
8. Remove the wheel chocks.

TRANSVERSE TRAAX ROD
WARNING

THE ROADMAAX AIR SUSPENSION INCORPORATES TRANSVERSE TRAAX RODS FOR VEHICLE STABILITY. IF THESE COMPONENTS ARE DISCONNECTED OR ARE NON-FUNCTIONAL THE VEHICLE SHOULD NOT BE OPERATED. FAILURE TO DO SO CAN RESULT IN ADVERSE VEHICLE HANDLING, POSSIBLE TIRE CONTACT WITH THE FRAME, SEVERE PERSONAL INJURY, AND PREMATURE COMPONENT DAMAGE.

NOTE

Transverse TRAAX ROD torque rods assemblies equipped on the ROADMAAX air suspension are not re-bushable. The entire torque rod assembly must be replaced. This feature provides superior bushing retention in the torque rod end hub.

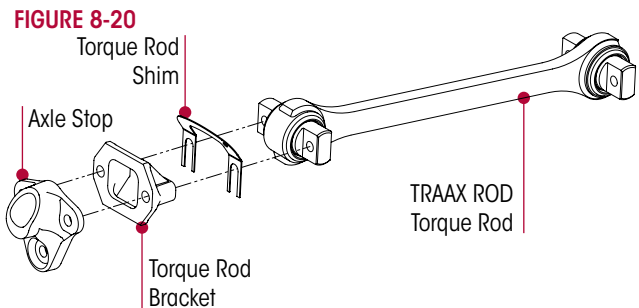
DISASSEMBLY

1. Chock the wheels of the vehicle.
2. Support the frame of the vehicle at ride height.

WARNING

THE VEHICLE MUST BE FIRMLY SUPPORTED WITH JACK STANDS PRIOR TO SERVICING. FAILURE TO DO SO CAN RESULT IN PERSONAL INJURY OR PROPERTY DAMAGE.

SERVICE HINT

Note the quantity and location of shims removed during disassembly, see Figure 8-20. The same quantity must be reinstalled in the same location in order to maintain the lateral alignment of the axle prior to disassembly. The lateral alignment procedure will need to be performed after assembly, see Alignment & Adjustments Section of this publication.

3. Remove and discard the M16 fasteners that connect the transverse TRAAX ROD to the frame bracket and axle.
4. Remove the transverse torque rod.
5. Inspect the mounting surfaces for any wear or damage. Replace as necessary.
6. Inspect the torque rod for straightness, wear, or cracks, replace as necessary.



ASSEMBLY

1. Install the transverse TRAAX ROD.
2. Install the mounting fasteners, supplied by vehicle manufacturer, and any shims that were removed.

NOTE

Hendrickson recommends the use of CL 10.9 bolts and CL 10 locknuts for all torque rod attachments.

-
3. Prior to tightening, ensure that the vehicle is at the proper ride height. Tighten all fasteners to the vehicle manufacturer's torque specification.
 4. Check the lateral alignment. If not within vehicle manufacturer's specified range, a lateral alignment is necessary. See Lateral Alignment in the Alignment & Adjustments Section of this publication.
 5. Remove the wheel chocks.



SECTION 9 Plumbing Diagram

For vehicles equipped with height control valve supplied by Hendrickson.

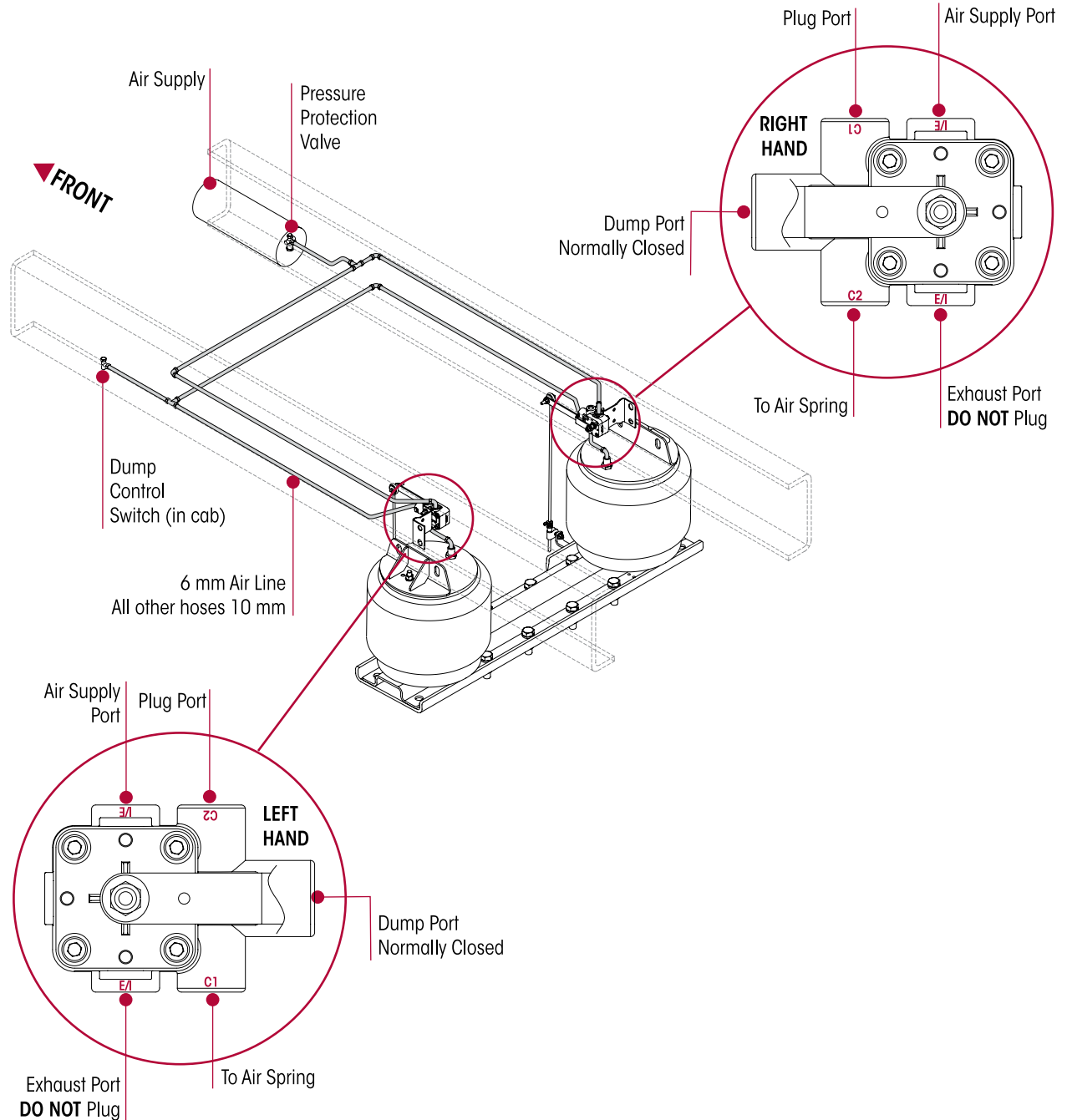

SECTION 10 Torque Specifications

**HENDRICKSON RECOMMENDED
TORQUE VALUES PROVIDED IN
FOOT POUNDS AND IN NEWTON METERS**

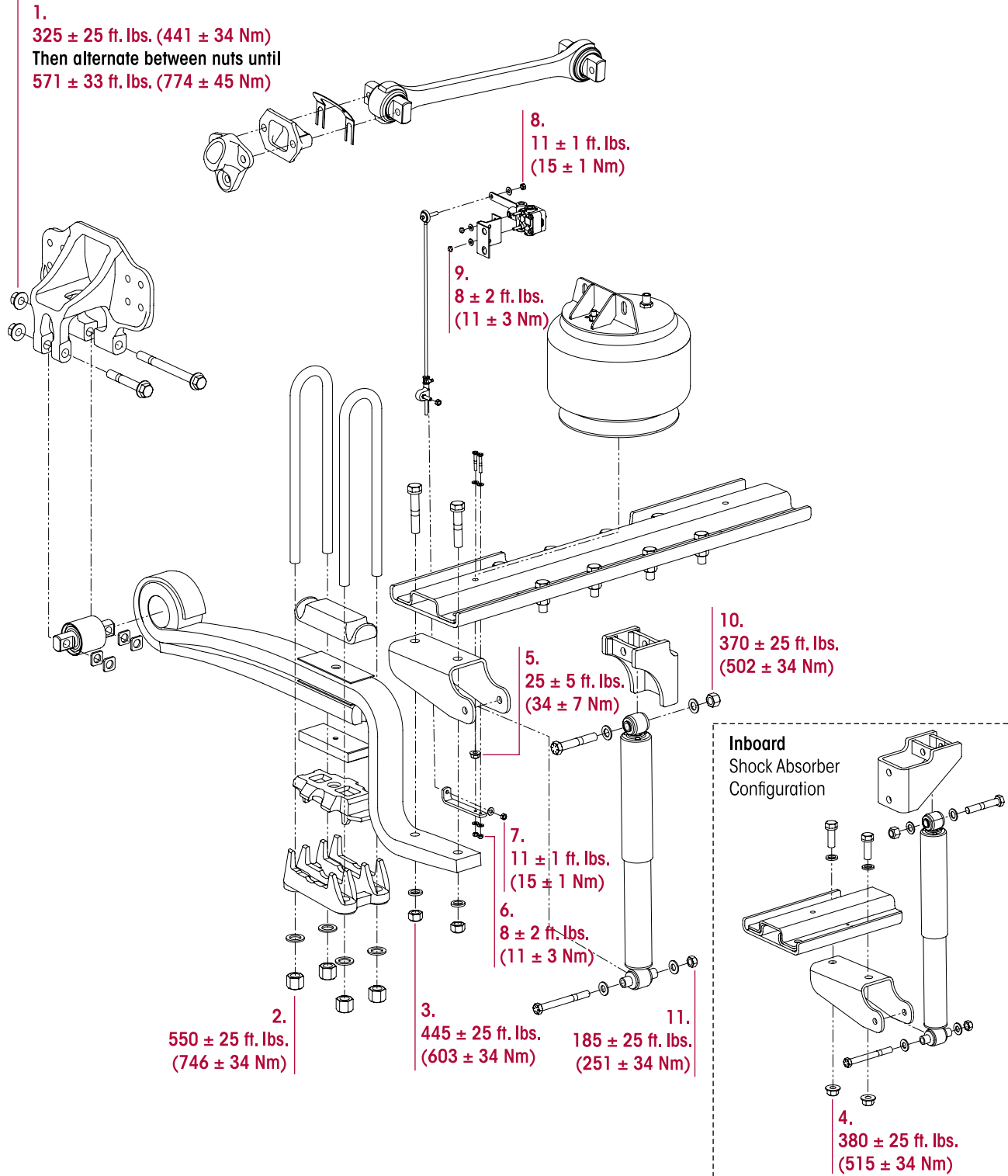



ROADMAAX Air Suspension for Fire and Rescue

HENDRICKSON RECOMMENDED TORQUE SPECIFICATIONS

NO.	COMPONENT	QUANTITY	SIZE	*TORQUE VALUE	
				FOOT POUNDS	NM
1	Frame Hanger to Main Support Assembly	4	M20	325 ± 25, then alternate between nuts until 571 ± 33 is achieved	441 ± 34, then alternate between nuts until 774 ± 45 is achieved
2	Clamp Group U-bolts	8	M24	550 ± 25	746 ± 34
3	Cross Channel to Main Support Member	4	M20	445 ± 25	603 ± 34
4	Cross Channel to Lower Shock Bracket	4	M20	380 ± 25	515 ± 34
5	Cross Channel to Lower Air Spring Piston	2	M12	25 ± 5	34 ± 7
6	Cross Channel to HCV Linkage Bracket	4	¼"	8 ± 2	11 ± 3
7	HCV Linkage to HCV Linkage Bracket	1	⅝"	11 ± 1	15 ± 1
8	HCV Linkage to Height Control Valve	1	⅝"	11 ± 1	15 ± 1
9	Height Control Valve to HCV Mounting Bracket	2	¼"	8 ± 2	11 ± 3
10	Upper Shock Absorber Mounting Fasteners	1	¾"	370 ± 25	502 ± 34
11	Lower Shock Absorber Mounting Fasteners	1	⅝"	185 ± 25	251 ± 34

NOTE: * Torque values listed above apply only if Hendrickson supplied fasteners are used. If non Hendrickson fasteners are used, follow torque specification listed in vehicle manufacturer's service manual.

SECTION 11

Troubleshooting Guide

ROADMAAX Air Suspension for Fire and Rescue

TROUBLESHOOTING GUIDE		
CONDITION	POSSIBLE CAUSE	CORRECTION
Vehicle bouncing excessively	Leaking shock absorber	Replace shock absorber.
	Damaged shock absorber	Replace shock absorber.
	Air spring(s) not inflated	Check air supply to air spring, repair as necessary.
	Incorrect ride height	Adjust ride height to proper setting. See Ride Height Adjustment in the Alignment & Adjustments Section of this publication.
Suspension has harsh or bumpy ride	Broken main support member assembly	Replace main support member assembly.
	Damaged height control valve	Replace height control valve.
	Incorrect ride height	Adjust ride height to proper setting. See Ride Height Adjustment in the Alignment & Adjustments Section of this publication.
Excessive driveline vibration	Incorrect ride height	Adjust ride height to proper setting. See Ride Height Adjustment in the Alignment & Adjustments Section of this publication.
	Broken main support member assembly	Replace main support member assembly.
	Air spring(s) not inflated	Check air supply to air spring, repair as necessary.
Vehicle leans	Broken main support member assembly	Replace main support member assembly.
	Axle connection not torqued correctly	Perform U-bolt re-torque procedure, see Preventive Maintenance Section of this publication.
	Worn pivot bushing	Replace pivot bushing.
	Air spring(s) not inflated	Check air supply to air spring, repair as necessary.
Suspension is noisy	Loose U-bolts	Perform U-bolt re-torque procedure. See the Preventive Maintenance Section of this publication.
Irregular tire wear	Worn pivot bushing	Replace pivot bushing.
	Loose frame hanger to main support member connection	Check suspension alignment. Check frame hanger for wear around main support member assembly and fasteners, replace as necessary.
Main support member broken between U-bolts	Loose U-bolts	Replace main support member assembly and all mating parts.
Frame hanger worn	Loose fasteners and/or the re-use of old fasteners	Replace all worn parts and replace fasteners with new fasteners.



Actual product performance may vary depending upon vehicle configuration, operation, service and other factors.
All applications must comply with applicable Hendrickson specifications and must be approved by the respective vehicle manufacturer with the vehicle in its original, as-built configuration.
Contact Hendrickson for additional details regarding specifications, applications, capacities, and operation, service and maintenance instructions.

*Call your truck dealer or Hendrickson at **1.866.755.5968** (toll-free) or **1.630.910.2800** for additional information.*



www.hendrickson-intl.com

TRUCK COMMERCIAL VEHICLE SYSTEMS
800 South Frontage Road
Woodridge, IL 60517-4904 USA
1.866.755.5968 (Toll-free U.S. and Canada)
1.630.910.2800 (Outside U.S. and Canada)
Fax 1.630.910.2899

17730-322 Rev A 07-19
© 2019 Hendrickson USA, L.L.C. All Rights Reserved. All trademarks shown are owned by Hendrickson USA, L.L.C., or one of the affiliates, in one or more countries.
Information contained in this literature was accurate at the time of publication. Product changes may have been made after the copyright date that are not reflected.

Printed in United States of America