



VANTRAA[®] / ULTRAA-K[®] Air Slider
Suspension Systems

- Maximized payloads
- Superior performance
- Reduced maintenance



To learn more about VANTRAA and
ULTRAA-K, call 866.743.3247 or visit
www.hendrickson-intl.com

HENDRICKSON
The World Rides On Us[®]

VANTRAAX® / ULTRAA-K® Air Slider Suspension Systems

ZMD® ZERO MAINTENANCE DAMPING® Technology

Innovative ride solution exclusive to Hendrickson

- Reduced suspension maintenance by eliminating shocks
- Air spring performs damping function by exchanging pressurized air through channels
- Uniform damping levels
- Robust chain down stop provides maximum durability
- Reduced risk of CSA violations due to leaking or worn shocks
- Superior driver comfort, ride quality and cargo protection

See ZMD flyer - L1209



Hendrickson-Installed UBL™ UNDER BEAM LIFT™*

Lightweight lift axle mechanism

- Operational flexibility
- Improved maneuverability
- Maximized payloads

See UBL flyer - L727

*Not available on ULTRAA-K®



TIREMAAX® PRO

Advanced tire pressure control system

- Automatically inflates tires using the trailer air supply
- Prevents over-inflation by relieving air from the tires back through the controller
- Patented[▲] controller is designed to recognize normal pressure increase due to operation

See TIREMAAX PRO brochure - L1199



Loading Dock Solutions

For more efficient loading and unloading

SURELOK®

- Maintains trailer deck height
- Limits trailer drop and walk
- Activates automatically with trailer parking brakes



DST® Dock Stabilizing Technology™

- Minimizes trailer walk
- Patented[▲] integral height control / dump valve exhausts twice as fast as conventional valves
- Activates automatically with trailer parking brakes
- Supports load on internal air spring bumpers

Manual and automatic dump valves

- Limit trailer drop and walk
- Support load on internal air spring bumpers

See SURELOK flyer - L622

See Trailer Loading Dock Terms and Solutions - L816

QUIK-DRAW®

Fully pneumatic slider pin system

- Driver friendly — finger-tip operation
- Helps reduce driver strain, enhances productivity
- Automatic reset engages pins when parking brake releases

See QUIK-DRAW flyer - L628



Brake Options

Extend intervals between brake service

- HXS® Hendrickson Extended Service™ brakes, with thicker lining blocks, extend brake life
- Wide HXS (16.5- × 8.625-inch) brakes can help increase the miles between lining changes
- Air disc brakes available

See Understanding Air Suspensions - (Brake Efficiency) - L761

See Air Disc Brake flyer - L889

RTR® READY-TO-ROLL®

Fully integrated solutions that help minimize operating costs and improve performance

- Suspension through wheel-end systems deliver low maintenance, improved durability and reduced weight with the convenience of a single-source supplier

— HXL3® Hendrickson Extended-Life 3-year System™*

— HXL5® Hendrickson Extended-Life 5-year System™*

— HXL7® Hendrickson Extended-Life 7-year System™*

See RTR READY-TO-ROLL Wheel-End flyer - L1200

Corrosion Protection / Coatings

Hendrickson coating options help protect your investment

- **Hot Dip Wax:** Exclusive to ULTRAA-K®, a self-healing, pliable coating that has the ability to re-seal itself in areas with minimal damage. Entire slider bogie is coated for exceptional coverage and comes with a 10-year structural corrosion warranty.*
- **Black or Grey Soft-Coat:** A self-healing, pliable coating that has the ability to re-seal itself in areas with minimal damage.
- **Hot-Dipped Galvanized:** Zinc coating for improved chip and corrosion resistance. Available on limited VANTRAAX slider boxes.
- **Black Primer:** Our premium black primer using a multi-stage cleaning and preparation process for high adhesion.
- **E-coat:** All Hendrickson brake shoes utilize a high quality, e-coat process for improved resistance to rust-jacking.
- **AAXTREME COAT®:** Premium brake shoe coating provides extreme corrosion protection in tough environments.

See E-coat brochure - L1205 See AAXTREME COAT flyer - L1207

*Contact your local Hendrickson representative or see L583 Comprehensive Warranty Statement for complete warranty terms, conditions and limitations.

▲ This product is covered by at least one or more U.S. and/or foreign patents and/or pending U.S. and/or foreign patent applications. See Hendrickson for details.

Family of low-maintenance

ULTRAA-K®

Hendrickson introduces the latest in air slider technology with ULTRAA-K® axle suspension system – the next generation VANTRAAX® air slider system for the van and refrigerated trailer markets. Building on proven VANTRAAX air slider design expertise, the ULTRAA-K system is engineered with an optimized strength-to-weight ratio making it stronger than comparable standard and heavy duty 40K slider models in the market today. It is nearly 100 pounds lighter than other competitive slider systems in the industry.

The ULTRAA-K system is standard with industry exclusive and patented[▲] features such as ZMD® ZERO MAINTENANCE DAMPING® technology, pivoting mud flap brackets and protected height control valve mounting.

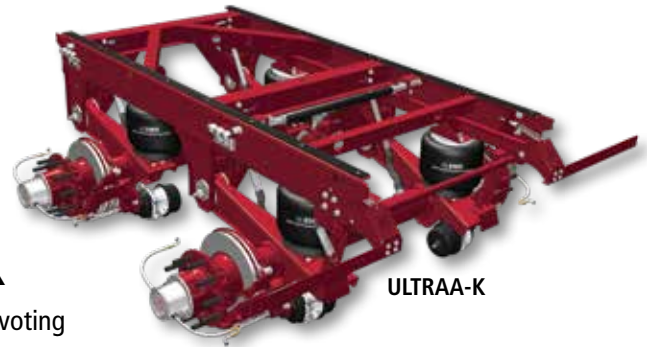

ULTRAA-K



HKANT 40K

HKANT 40K

Optimized for dry-freight and refrigerated sliding tandems, VANTRAAX HKANT 40K with a capacity rating of 40,000 pounds remains one of the lightest air suspension systems on the market. At the same time, it addresses critical needs for a superb ride, rugged durability and low maintenance. The patented[▲] QUIK-DRAW® pin activation system helps protect both drivers and payload.

Featuring the LDA™ Large-Diameter Axle for increased roll stiffness, reduced weight and improved durability, the HKANT 40K helps haulers boost payloads and enhance fuel efficiency. ZMD ZERO MAINTENANCE DAMPING technology is available as an option on the HKANT 40K model.

HKANT 46K

This lightweight, tapered-beam 46,000-pound capacity system, features LDA axles and is tailor made for haulers running heavy-duty, over-the-road box and refrigerated vans. The VANTRAAX HKANT 46K incorporates our patented[▲] QUIK-DRAW pin activation system, high-strength main rails and "K" braces for superior durability and frame strength. The close-spaced model is up to 175 pounds lighter than similar 46K systems.



HKANT 46K



HKANT 46K Wide spread

HKANT 46K – Wide Spread

A 121-inch spread configuration, the VANTRAAX 46K Wide Spread has the same features as the close-spaced 46K, while providing flexibility in load distribution and saving more than 350 pounds when compared to equivalent models.

HKANT 23K

This 23,000-pound capacity system provides flexibility in axle spacing, allowing for increased carrying capacity and enhanced load distribution. The VANTRAAX HKANT 23K comes standard with QUIK-DRAW, resulting in a system 200 pounds lighter than competitive models. This model also features the LDA axle for lighter weight and improved durability.



HKANT 23K

[▲] This product is covered by at least one or more U.S. and/or foreign patents and/or pending U.S. and/or foreign patent applications. See Hendrickson for details.

air slider suspension systems

HKAT 50K

With a capacity of 50,000 pounds, this rugged, durable VANTRAAX model featuring the LDA™ axle proves ideal for haulers carrying heavier loads or running on secondary and unpaved highways.



HKAT 50K



HKAT 69K25 Tridem

HKANT 69K Tridem

Hendrickson's VANTRAAX® tridem sliders provide an ideal solution for haulers moving freight across North America. Tridems give operators the flexibility to haul across international, provincial and state borders, helping them remain compliant with a wide variety of bridge weight laws and Canadian "infrastructure-friendly" regulations. The VANTRAAX HKANT 69K23 and HKAT 69K25 models feature an overall system capacity of 69,000 pounds and axle ratings of 23,000 and 25,000 pounds respectively.

VANTRAAX tridem sliders feature the LDA Large-Diameter Axle for increased roll stiffness, reduced weight and improved durability helping haulers boost payloads and enhance fuel efficiency.

HKANL 23K - Liftable Single-Axle Slider

This liftable 23,000-pound capacity single-axle air slider system features LDA. This product has been specially designed with a larger amount of suspension up travel to provide increased suspension lift. The HKANL 23K can be useful in applications where one or two lift axles are used with a "standard travel" fixed or sliding tandem arrangement. In addition, this system provides flexibility in axle spacing, allowing for increased carrying capacity and enhanced load distribution, and it comes standard with QUIK-DRAW®, resulting in additional weight savings when compared to similar models.



HKANL 23K

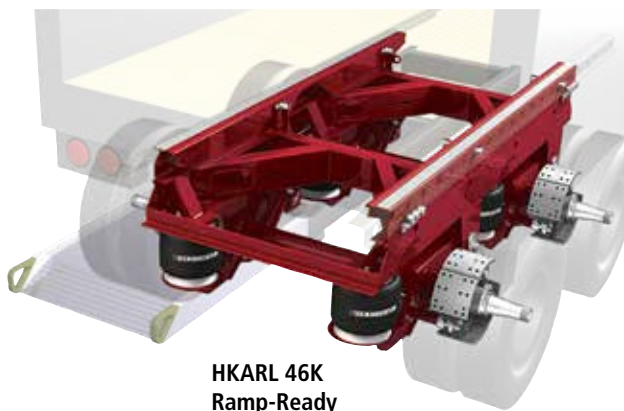

HKARL 46K
Ramp-Ready

HKARL 46K Ramp-Ready

Eliminating heavy, expensive spacer tubes, the Ramp-Ready VANTRAAX delivers the competitive advantages, cutting-edge technology and weight savings of an advanced system. With a capacity of 46,000 pounds, VANTRAAX Ramp-Ready features Hendrickson's LDA and a 6.5- by 30-inch ramp bay and installs on applicable trailers using industry standard body rails with four- or six-inch pin hole spacing.

HKAL 46K

Ideal for drop-frame van applications, VANTRAAX HKAL 46K is standard with Hendrickson's LDA and provides fleets and owner operators with a lighter, more durable product that helps reduce operating costs over the long run.





HKAL 46K

Weigh the advantages of VANTRAAX® / ULTRAA-K®

Superior Axle Design

Hendrickson stands as one of the world's largest trailer axle manufacturers





- LDA™ Large-Diameter Axle — standard on all VANTRAAX® models
 - Trims up to 30 pounds per axle compared to a five-inch diameter axle, allowing more cargo per load
 - Bending and torsional stiffness increased by as much as 22 percent for rugged durability and reduced deflection under load
 - Greater roll stability
- Straighter, neutral-toe axle helps improve tire life and fuel mileage
- Advanced axle wrap and window weld technology for optimal structural integrity 
- Spindle, axle wrap and spider mounting surfaces machined in one step after friction welding to ensure precise brake geometry and wheel positioning — providing enhanced brake life and efficiency
- Brake hardware attached to trailing arms rather than welded to axle, minimizing axle stress 
- Patented[▲] axle filter prevents wheel-end contamination

K-2® Slider Box Technology — More Strength, Less Weight

- Patented[▲] "K" bracing absorbs road jolts
- Superior strength-to-weight ratio for longer life
- Slides easily on durable, full-length slider pads

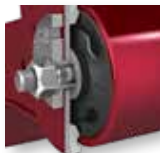

Low Maintenance and Convenience — Save Time and Money

- Simple, functional design uses fewer parts — that means fewer parts to wear out 
- QUIK-ALIGN® — fast and easy axle realignment requires no welding or special tools
- TRI-FUNCTIONAL® Bushings — proven technology for mile after mile of dependable service 
- Single source for comprehensive technical support, training and warranty

Responsive and Consistent Stopping Power

- Hendrickson's standard Cam Tube System™ enhances S-cam alignment and helps extend brake component life
 - Seven times more grease than spherical-style camshaft assemblies
- 10-inch S-cam eliminates windup and reduces bushing wear
 - Up to a half inch less stroke required
 - Provides more braking reserve — without the cost of long-stroke chambers
 - Lower air consumption, critical for ABS performance
 - Faster application and release cycles
- Heat-treated components for greater durability



Performance Plus

- Low spring rates deliver superb ride quality
- Optional high-capacity air springs allow rapid air-up 
- Rigid trailing arm with solid axle connection offers stable and durable design
- TRI-FUNCTIONAL Bushings optimize ride softness and control
- Quality-controlled assembly including ABS sensor testing ensures optimal performance

Low-Maintenance Integrated Systems from a Single Source

- Long-term warranty on axle / beam connection*
- Leading structural warranty*
- Supported by OEMs, dealers and designated distributors throughout North America
- Backed by Hendrickson's outstanding technical support staff
- Quickly replace damaged axles without grinding or welding
- Wide availability of Hendrickson Genuine Parts

* Applicable for most geographic areas and applications. Contact your local Hendrickson representative for complete warranty terms, conditions and limitations.

▲ This product is covered by at least one or more U.S. and/or foreign patents and/or pending U.S. and/or foreign patent applications. See Hendrickson for details.



VANTRAAX® / ULTRAA-K® Built to last

VANTRAAX® and ULTRAA-K® address the industry's need for lighter, more durable products that help reduce operating costs. Fleet owners and owner-operators insist on Hendrickson slider systems for their dry-freight and refrigerated vans to take advantage of superior performance, added payload and enhanced cargo protection.



VANTRAAX marries our superior K-2® slider box technology with the patented[▲] INTRAAX® integrated suspension / axle / brake system recognized industry-wide for its durable performance and lightweight design. This winning combination of legendary durability and road-proven reliability contributes to the enduring value of VANTRAAX.

The VANTRAAX family has grown to include a variety of slider models to cover a whole range of North American trailer applications and operating conditions. Close-spaced tandems in top-mount and low-ride configurations, as well as tridems in wide-spread configurations, provide the product depth you have come to expect from Hendrickson.

The latest innovation in trailer air slider systems is ULTRAA-K – the next generation VANTRAAX air slider suspension system. Building on the proven VANTRAAX design, ULTRAA-K is engineered with an optimized strength-to-weight ratio making it stronger and nearly 100 pounds lighter than comparable air slider suspension systems. ULTRAA-K is an elite system that features exclusive and patented[▲] Hendrickson technology.

[▲] This product is covered by at least one or more U.S. and/or foreign patents and/or pending U.S. and/or foreign patent applications. See Hendrickson for details.

VANTRAAX / ULTRAA-K Specifications

Model	Axle Arrangement	Axle Spacing (inches)	System Capacity (pounds)	Axle Rating (pounds)	Axle Diameter	Box Width (inches)	Ride Height (inches)*	Base Model Weight (pounds)**
ULTRAA-K	Tandem	49	40,000	20,000	LDA™	48	16	1,294
HKANT 23K	Single	N/A	23,000	23,000	LDA	42, 48, 54	16, 17	785
HKANT 40K	Tandem	49	40,000	20,000	LDA	42, 48, 54	16, 17	1,394
HKANT 46K	Tandem	49, 121	46,000	23,000	LDA	42 [^] , 48, 54	16, 17	1,405
HKAT 50K	Tandem	49	50,000	25,000	LDA	42, 48	16, 17, 18, 19	1,579
HKANT 69K23	Tridem	49, 60, 72	69,000	23,000	LDA	48, 54	16, 16.5, 17, 18	2,236
HKAT 69K25	Tridem	60, 72	69,000	25,000	LDA	42, 48, 54	16, 17, 18	2,479
HKANL 23K	Single	N/A	23,000	23,000	LDA	42, 48, 54	17	857
HKAL 46K	Tandem	49	46,000	23,000	LDA	42, 48	10, 11	1,670
HKARL 46K	Tandem	49	46,000	23,000	LDA	48	10, 11	1,840

* Contact Hendrickson for non-standard ride height availability.

** Weights include slider, suspensions, HN spindles and foundation brakes for 48-inch wide slider box. Tandem weights are based on 49-inch axle spacing. Tridem weights are based on 72-inch axle spacing. ULTRAA-K weight does not include pivoting mud flap brackets, HCV kit or air tank brackets.

[^] Not available on 121-inch axle spread model.

Actual product performance may vary depending upon vehicle configuration, operation, service and other factors.

All applications must comply with applicable Hendrickson specifications and must be approved by the respective vehicle manufacturer with the vehicle in its original, as-built configuration. Contact Hendrickson for additional details regarding specifications, applications, capacities, and operation, service and maintenance instructions.

Call Hendrickson at **330.489.0045** or **866.RIDEAIR (743.3247)** for additional information.



www.hendrickson-intl.com

TRAILER COMMERCIAL VEHICLE SYSTEMS

2070 Industrial Place SE
Canton, OH 44707-2641 USA
866.RIDEAIR (743.3247)
330.489.0045 • Fax 800.696.4416

Hendrickson Canada

250 Chrysler Drive, Unit #3
Brampton, ON Canada L6S 6B6
800.668.5360
905.789.1030 • Fax 905.789.1033

Hendrickson Mexicana

Circuito El Marqués Sur #29
Parque Industrial El Marqués
Pob. El Colorado, Municipio El Marqués,
Querétaro, México C.P. 76246
+52 (442) 296.3600 • Fax +52 (442) 296.3601

L585 Rev S 08-20

© 1997 - 2020 Hendrickson USA, L.L.C. All Rights Reserved. All trademarks shown are owned by Hendrickson USA, L.L.C., or one of its affiliates, in one or more countries. Information contained in this literature was accurate at the time of publication. Product changes may have been made after the copyright date that are not reflected.

Printed in United States of America