

- Exceptional weight savings
- Optimized design
- Proven Hendrickson quality

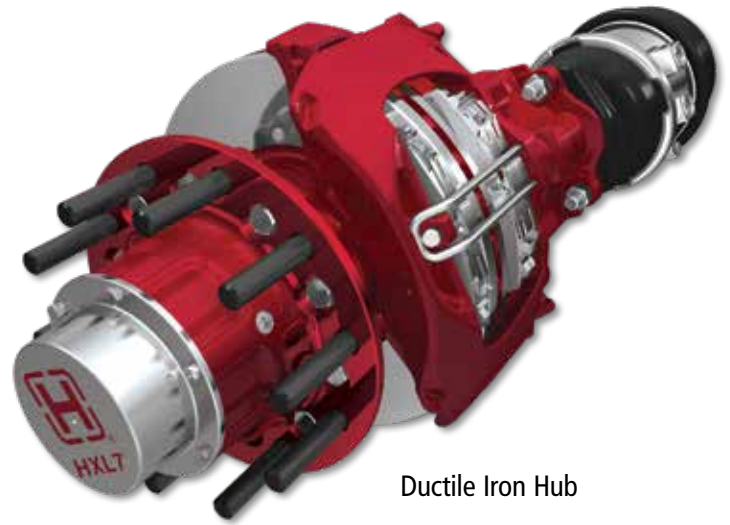

Dura-Light Hub®



Ductile Iron Hub

Exceptional Weight Savings

Hendrickson MAXX22T™ offers significant weight savings over similar designs while still maintaining the quality and reliability fleets and owner operators expect from Hendrickson. Fleets can take advantage of additional weight savings by specifying Hendrickson's latest addition to the MAXX22T line-up – the Dura-Light Hub®.

Optimized Design

Hendrickson continues to address the industry's demand for advanced trailer air disc brakes with the introduction of the proprietary MAXX22T air disc brake system featuring WABCO brake technology. MAXX22T is specifically designed to optimize performance for North American trailer applications and incorporates premium features exclusive to Hendrickson.

Proven Hendrickson Quality

Hendrickson infuses design expertise, state-of-the-art R&D capabilities and proven assembly processes to create a unique addition to our lineup of fully integrated ride solutions. MAXX22T is the only air disc brake system offered with Hendrickson's comprehensive warranty coverage on all wheel-end, brake and suspension components, giving you peace of mind from a recognized leader in the industry.



To learn more about MAXX22T,
call 866.743.3247 or visit
www.hendrickson-intl.com
www.MAXX22T.com

MAXX22T™ Trailer Air Disc Brake System

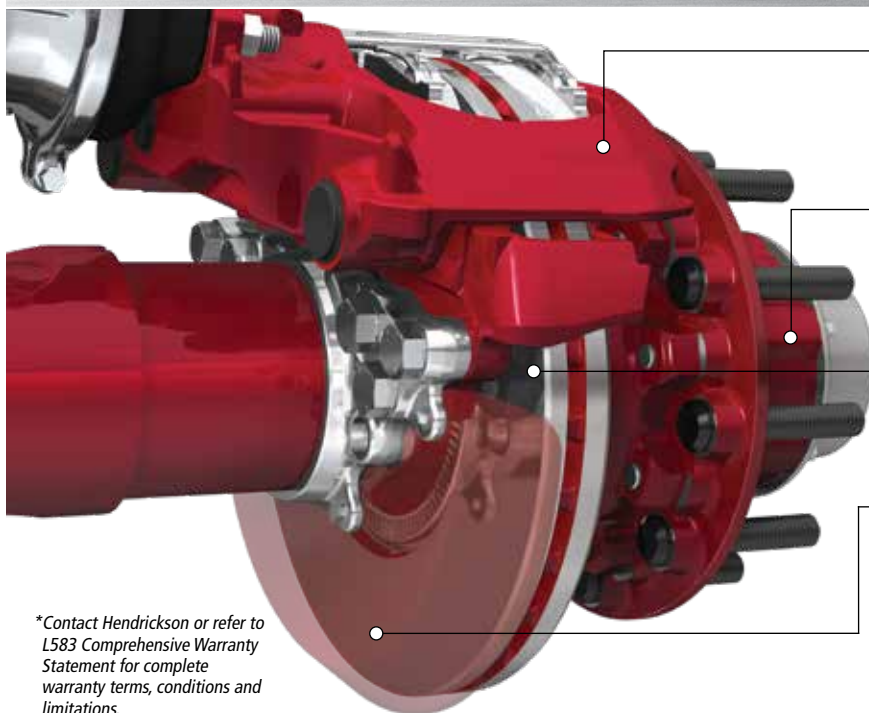

*Contact Hendrickson or refer to L583 Comprehensive Warranty Statement for complete warranty terms, conditions and limitations.

Hendrickson proprietary MAXX22T™ Brake Caliper

- Utilizes WABCO single piston technology for higher reliability and reduced weight
- Compact and lightweight mono-block design
- Sealed and protected guide system

Hendrickson Extended-Life Wheel-End System

- HXL3®, HXL5® or HXL7® extended-life wheel-end systems
- Hub cap to hub cap warranty* provided by Hendrickson for the entire suspension and wheel-end braking system
- Available with ductile iron hub or lightweight Dura-Light Hub®

Lightweight Rotor

- Weight optimized cast rotor
- Increased valve stem clearance
- All surfaces e-coated for longer corrosion protection

Dust Shield

- Bolt-on design for easier installation and maintenance
- E-coated to provide longer corrosion protection
- Built-in clearance to allow for simplified rotor inspection

Specifications

All Hendrickson MAXX22T air disc brake packages include installation of disc brake calipers, air chambers, lining pads, hub and rotor assemblies, bearings, seals, hub caps, dust shield / splash guard and lubricant.

Application Information

- 1. Wheel and valve stem packaging** — **CAUTION:** Great care must be taken in selecting combinations of wheel and valve stem products that are compatible with air disc brakes. Trailer OEM's will need to review wheel-end and valve stem packaging to confirm adequate running clearances. Hendrickson engineering can assist customers to determine component compatibility.
- 2. ABS sensors** — Hendrickson fully dressed trailer suspensions require straight ABS sensors. MAXX22T requires ABS sensing via rotor-mounted tone rings.
- 3. Suspension availability** — MAXX22T air disc packages are available on most Hendrickson INTRAAX®, INTRAAX SP, VANTRAAX® and ULTRAA-K® integrated suspension systems and TRLAXLE® non-integrated axles.
- 4. Brake rating** — MAXX22T air disc brakes are rated up to 23,000 lbs. GAWR with select tire static load radius (SLR). Refer to L809 Brake Certifications for more information.

* Contact your Hendrickson representative for a complete listing of MAXX22T options. TIREMAAX® tire inflation system is also available as an option with all air disc brake packages.

Hendrickson suspensions available with MAXX22T air disc brakes (ADB)

SUSPENSION / AXLE MODELS	AVAILABILITY*
INTRAAX	
AANT 23K	ADB OK – requires unique HCV
AANLS 20K / AANL 23K	Requires rear mounted and unique HCV
AAT 23K, 25K, 30K	ADB OK without SURELOK® – requires unique HCV
AAL 23K, 25K, 30K	ADB OK - Requires rear mounted shocks
AAEDL 30K / AAEDT 30K	MAXX22T ADB not available
INTRAAX SP	
AAZNT 23K, 46K	Requires unique HCV
AAZNT 69K	ADB OK
ULTRAA-K	
UTKNT 40K	ADB OK
VANTRAAX	
HKANT 23K, 40K, 46K, 69K23	ADB OK
HKAT 50K	ADB OK without SURELOK – requires unique HCV
HKAT 69K25, HKARL 46K	ADB OK without SURELOK
HT SERIES	
HT230T, HT250T, HT300T, HT250YB	Call Hendrickson for application approval
HT250U	Call Hendrickson for application approval
TRLAXLE	
TRLAXLE - 1/2-in, 5/8-in, 5/8-in HD wall	ADB available on limited tracks

Actual product performance may vary depending upon vehicle configuration, operation, service and other factors.

Call Hendrickson at 330.489.0045 or 866.RIDEAIR (743.3247) for additional information.



www.hendrickson-intl.com

L1239 Rev G 01-20

© 2015 – 2020 Hendrickson USA, L.L.C. All Rights Reserved. All trademarks shown are owned by Hendrickson USA, L.L.C., or one of its affiliates, in one or more countries, except for (1) Dura-Light Hub, which is owned by Walther Engineering & Manufacturing Company, Inc. and (2) WABCO, which is owned by WABCO IP Holdings LLC. Information contained in this literature was accurate at the time of publication. Product changes may have been made after the copyright date that are not reflected.

TRAILER COMMERCIAL VEHICLE SYSTEMS

2070 Industrial Place SE
Canton, OH 44707-2641 USA
866.RIDEAIR (743.3247)
330.489.0045 • Fax 800.696.4416

Hendrickson Canada

250 Chrysler Drive, Unit #3
Brampton, ON Canada L6S 6B6
800.668.5360
905.789.1030 • Fax 905.789.1033

Hendrickson Mexicana

Circuito El Marqués Sur #29
Parque Industrial El Marqués
Pob. El Colorado, Municipio El Marqués,
Querétaro, México C.P. 76246
+52 (442) 296.3600 • Fax +52 (442) 296.3601