



ASSEMBLY INSTRUCTIONS

HAULMAAX® EX • HAULMAAX®

SUBJECT: Aftermarket Shock Absorber Service Kits

LIT NO: 59310-012

DATE: October 2020

REVISION: D



INTRODUCTION

This publication is intended to assist maintenance personnel with the installation, on an as-needed basis, of HAULMAAX® EX • HAULMAAX® Aftermarket Shock Absorber Service Kits for vehicles not originally equipped with optional shock absorbers by the vehicle manufacturer.

Hendrickson requires shock absorbers for HAULMAAX EX • HAULMAAX rear suspensions to be used in tractor and logging applications. Shock absorbers may also improve HAULMAAX EX • HAULMAAX ride and traction in other applications. Ride performance can be subjective and may be dependent on many factors beyond the suspension design such as cab suspension, road conditions, body / auxiliary equipment, frame specifications, etc.

See Hendrickson publications 17730-328 (HAULMAAX EX) and 17730-244 (HAULMAAX) for complete safety and service instructions available online at www.hendrickson-intl.com.

WARNING

DO NOT USE THESE AFTERMARKET SHOCK ABSORBER SERVICE KITS IN CONJUNCTION WITH DUAL 315 mm WIDE TIRES. THE KITS INCLUDE LOWER SHOCK MOUNTING BRACKETS THAT CAN INTERFERE WITH 315 mm TIRES AND CAUSE TIRE DAMAGE AND POSSIBLE ADVERSE VEHICLE HANDLING, PERSONAL INJURY OR PROPERTY DAMAGE.

WARNING

A TECHNICIAN USING A SERVICE PROCEDURE OR TOOL WHICH HAS NOT BEEN RECOMMENDED BY HENDRICKSON MUST FIRST SATISFY HIMSELF THAT NEITHER HIS SAFETY NOR THE VEHICLE'S SAFETY WILL BE JEOPARDIZED BY THE METHOD OR TOOL SELECTED. INDIVIDUALS DEVIATING IN ANY MANNER FROM THE INSTRUCTIONS PROVIDED WILL ASSUME ALL RISKS OF CONSEQUENTIAL PERSONAL INJURY OR DAMAGE TO EQUIPMENT INVOLVED.

SHOCK ABSORBER ASSEMBLY

INSTALLATION

1. Chock the front wheels of vehicle to prevent movement during installation.
2. Support rear axles and frame on stands and remove rear tires.
3. On one side of the suspension, starting at the vertical centerline of (frame hanger/outboard frame bracket), measure  both directions horizontally along the vehicle frame rail and draw a vertical line, see Figure 1. See Table 1 to determine the correct upper shock bracket vertical hole locations based upon the vehicle's rear axle spacing.

Aftermarket Shock Absorber Kits

KIT NUMBER	SADDLE HEIGHT
64178-003	16½"
64178-004	17½" • 18½"
64178-009 • Mack Only	16½"
64178-032	18¼"
64178-033	20½"

Kit Contents

DESCRIPTION	QUANTITY
Shock Absorber Assembly	4
Upper Shock Bracket	4
Upper Shock Bracket Fastener Kit	As Req.
Lower Shock Front Bracket	2
Lower Shock Rear Bracket	2
Lower Shock Bracket Fastener Kit	As Req.

NOTE: Shock bracket to frame fasteners are not included in the kit.





- Measure up from the bottom of the frame rail $2\frac{1}{2}$ " and draw a horizontal cross line for the **lower hole position** of the upper shock bracket, see Figures 1 and 2.

NOTE

If an existing hole is already in the frame rail is close to this location, move the location fore or aft by ($\pm \frac{3}{8}$ ") to use the existing hole. **DO NOT** change the elevation (maintain the $2\frac{1}{2}$ " distance from the bottom of the frame rail) of the hole to accommodate an existing hole.

TABLE 1

Rear Axle Spacing	Vertical Hole Location
	Measurement A
52"	18½"
54"	19½"
60"	22½"
72"	28¾"

NOTE: Measure **A** in both directions. From the centerline of the outboard frame bracket

- Drill **ONLY** the upper shock bracket **LOWER HOLES** at the two locations in the frame rail to accommodate the $\frac{5}{8}$ " bolts, see Figures 1 and 2.
- Install the upper shock brackets to the frame and snug lower hole fasteners as per vehicle manufacturer's specifications. **DO NOT** tighten to torque at this time.

NOTE

The Aftermarket Shock Kit contains longer replacement bar pin bolts needed to accommodate the lower shock bracket.

- Remove and discard the existing bar pin fasteners from the outboard side of the equalizing beam.

NOTE

The Aftermarket Shock Absorber Service Kits lower front and rear shock brackets vary for only one OEM (Mack Service Kit No. 64178-009) which uses the same lower shock bracket for both front and rear. Ensure the proper bracket is used prior to installation of the lower shock bracket, part numbers are stamped on the bracket.

- Install the **FRONT** lower shock bracket (Part No. 64148-001) and new fasteners. A 1" flat washer must be located between the lower shock bracket and the axle bracket, as shown in Figure 3.
- Repeat Step 8 for the **REAR** lower shock bracket (Part No. 64148-002).
- Snug the bar pin fasteners, ensure locknuts are facing outward. **DO NOT** tighten at this time.
- Install the lower end of the shock absorber into the lower shock bracket and snug the **lower** shock absorber fasteners. **DO NOT** tighten to torque at this time.
- Install the upper end of the shock absorber into the upper shock bracket and install the lower hole fasteners. Snug the upper shock absorber fasteners. **DO NOT** tighten to torque at this time.

**FIGURE 1
HAULMAAX EX**

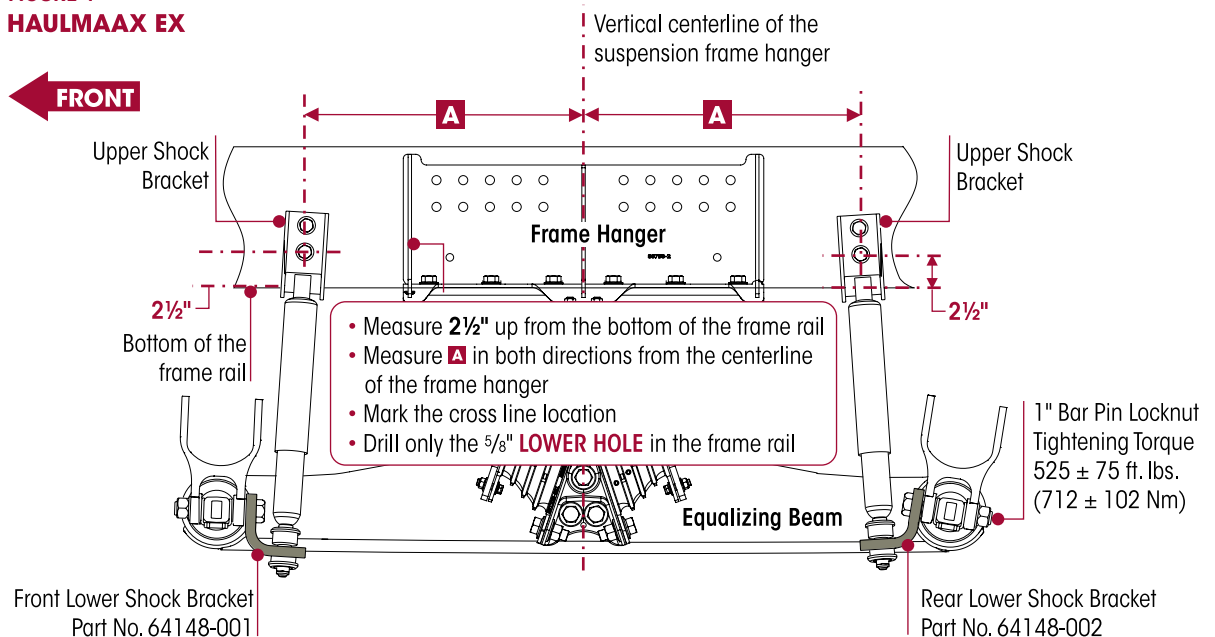
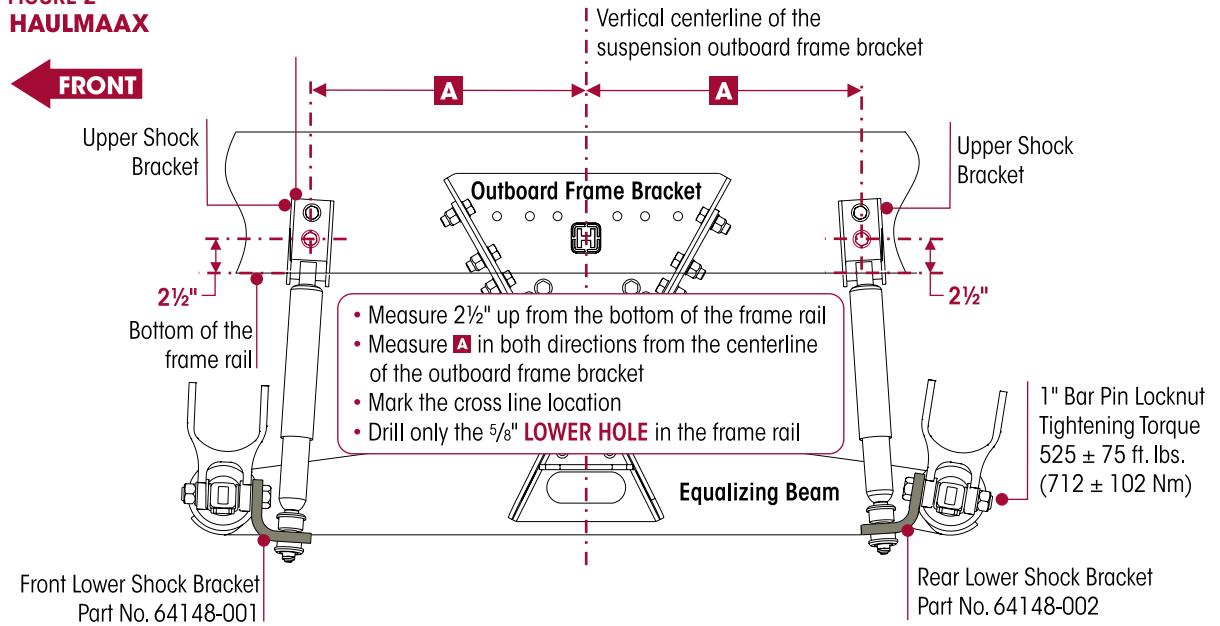



FIGURE 2
HAULMAAX



- Use the upper shock bracket as a guide to drill the **top mounting hole** in the frame rail.
- Install the upper shock bracket top mounting hole fasteners and tighten all the upper shock bracket frame fasteners per the vehicle manufacturer's specifications.
- Tighten the 1" bar pin fasteners \mathbb{R} 525 ± 75 foot pounds torque, see Figure 3.
- Tighten the **lower** shock absorber fasteners first to \mathbb{R} 80 ± 10 foot pounds torque, see Figure 2, then tighten the **upper** shock absorbers fasteners to \mathbb{R} 160 ± 10 foot pounds torque.
- Repeat Steps 3 to 16 for the other side of the vehicle.
- Paint as required to prevent corrosion to components.
- Install rear tires.
- Remove wheel chocks.

Refer any question regarding this publication to Hendrickson Tech Services.

FIGURE 3

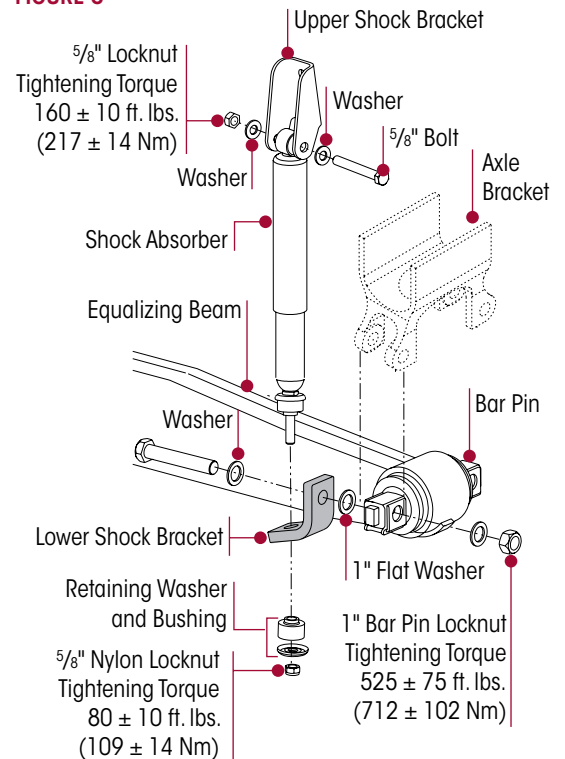

Toll-free U.S. and Canada
1.866.755.5968
Outside U.S. and Canada
1.630.910.2800



Parts Identification
truckparts@hendrickson-intl.com
Technical Support
techservices@hendrickson-intl.com



1.630.910.2899



Additional Hendrickson
Product Information
www.hendrickson-intl.com

Call Hendrickson at **1.866.755.5968** (toll-free) or **1.630.910.2800** for additional information.



www.hendrickson-intl.com

TRUCK COMMERCIAL VEHICLE SYSTEMS

800 South Frontage Road
Woodridge, IL 60517-4904 USA
1.866.755.5968 (Toll-free U.S. and Canada)
1.630.910.2800 (Outside U.S. and Canada)
Fax 1.630.910.2899

59310-012 Rev D 10-20

© 2003 – 2020 Hendrickson USA, L.L.C. All Rights Reserved. All trademarks shown are owned by Hendrickson USA, L.L.C., or one of the affiliates, in one or more countries. Information contained in this literature was accurate at the time of publication. Product changes may have been made after the copyright date that are not reflected.

Printed in United States of America