

**H** **CONNEX<sup>®</sup> ST**  
**TRAILER SELF-STEER**  
**SUSPENSION SPECIFICATIONS**

LIT NO: L1247

DATE: November 2019      REVISION: B

---

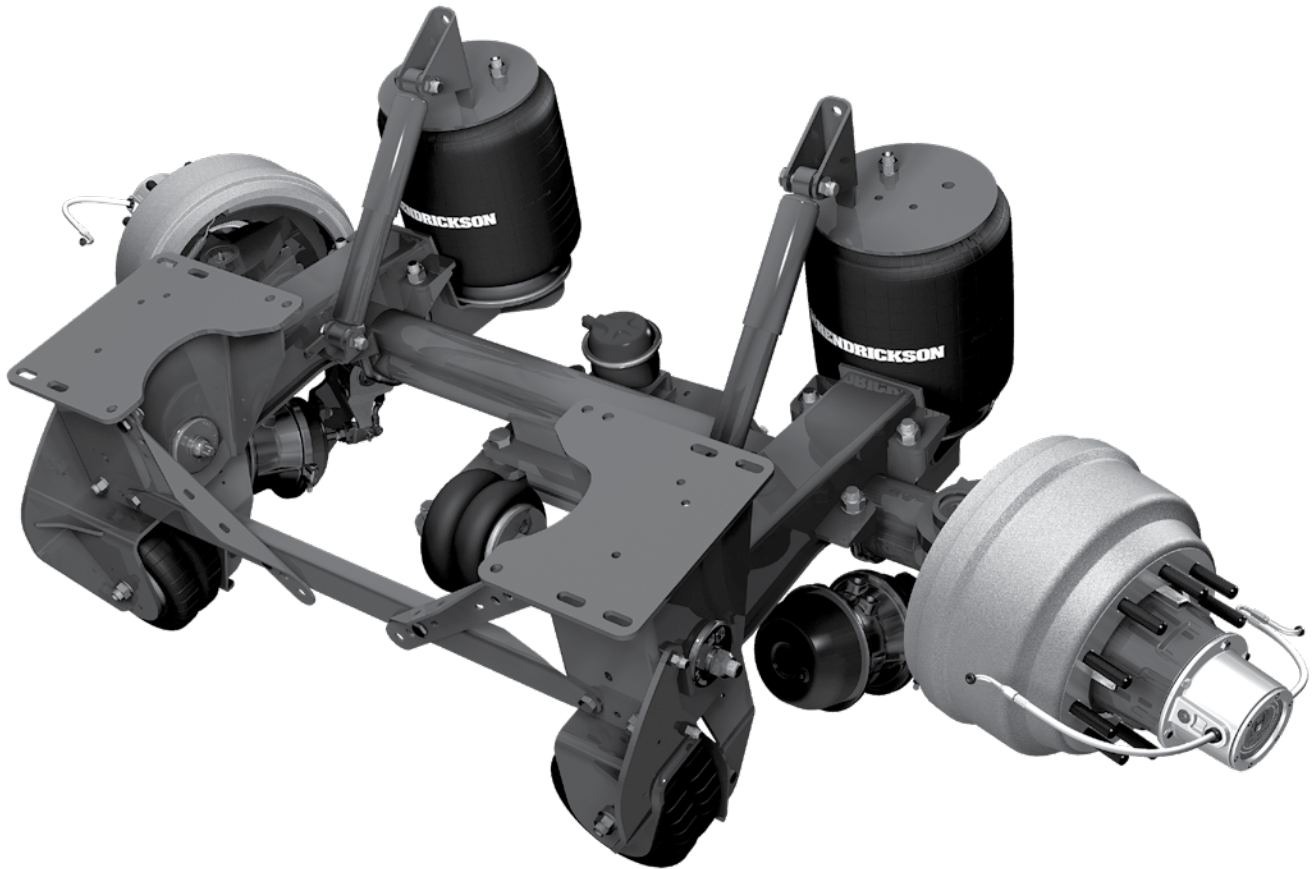

# CONNEX® ST TRAILER SELF-STEER SUSPENSION SPECIFICATIONS



APPLICATIONS	
<b>*CAPACITY:</b>	25,000 lbs. (11,300 kg)
<b>TRAILER TYPES:</b>	Van, Flat, Platform, Dump, Tanker, Grain
<b>AXLE DATA:</b>	5-inch diameter round, 3/4-inch wall
<b>AXLE ARRANGEMENT:</b>	Tri, Quad or more suspensions
<b>FRAME TYPES:</b>	Steel or aluminum; 96-inch or 102-inch wide trailers
<b>**WHEEL CUT:</b>	Adjustable from 20 to 30 degrees
<b>WHEEL COMPATIBILITY:</b>	Duals, wide-based singles or super singles
<b>LIFTABLE:</b>	Available with UBL™ UNDER BEAM LIFT™ Kits. See table below for suspension lift.
<b>BASE MODEL DESCRIPTION:</b>	CONNEX® ST trailer self-steer suspension system, 14 inch ride height, weld-on, winged frame brackets with QUIK-ALIGN®, 77.5-inch track axle, HP spindles, standard shocks, 16.5-inch x 7-inch drum brakes, ABS brackets, Cam Tube System™, type 30 brake chambers, 5.5-inch slack adjusters and HXS® 20K brake lining. Dust shields included and equipped with RTR® READY-TO-ROLL® wheel-end package, HXL5® Hendrickson Extended-Life 5-year system™. Equipped with ductile iron hub and standard duty cast drum.
<b>***BASE MODEL WEIGHT:</b>	1,440 lbs.
<b>OTHER OPTIONS:</b>	Additional options include bolt-on frame brackets with weld-on or bolt-on c-channel with struts. Brake lining options are HXS 23K with type 30/30 brake chambers and 6-inch slack adjusters. Ride heights range from 13 inches to 19 inches with various axle tracks including 79.5, 80, 81, 83.5, 84, 85 and 86 inches. HXL3® Hendrickson Extended-Life 3-year system™ also available. TIREMAAX® CP & PRO tire inflation systems available. Contact your Hendrickson representative to discuss these and other product options.

\* Capacity refers to suspension ratings, except where noted. Ratings for brakes and wheel-end components differ depending upon options chosen.

\*\* Availability based on trailer frame geometry, axle, axle track, suspension frame bracket spacing, wheel cut and tire size combinations.

\*\*\* Based on 14-inch ride height model with 77.5-inch axle track, basic brake package and RTR READY-TO-ROLL wheel-ends.

## SPECIFICATIONS

CONNEX® ST			
RISE HEIGHT (inches)	JOUNCE <sup>1</sup> (inches)	REBOUND <sup>1</sup> (inches)	LIFT (inches)
13	5.0	4.2	4.4
14	6.0	3.2	5.4
15	6.5	3.1	5.9
16	6.1	3.0	5.5
17	6.5	3.1	5.9
18	6.1	3.0	5.5
19	6.5	3.1	5.9

<sup>1</sup> Jounce and rebound figures are shown for models with standard weld-on frame brackets and standard shock absorbers. These values differ slightly for other models and options. Contact Hendrickson for more information.

*Actual product performance may vary depending upon vehicle configuration, operation, service and other factors.*

*All applications must comply with applicable Hendrickson specifications and must be approved by the respective vehicle manufacturer with the vehicle in its original, as-built configuration. Contact Hendrickson for additional details regarding specifications, applications, capacities, and operation, service and maintenance instructions.*

**Call Hendrickson at 330.489.0045 or 866.RIDEAIR (743.3247) for additional information.**



www.hendrickson-intl.com

### TRAILER COMMERCIAL VEHICLE SYSTEMS

2070 Industrial Place SE  
Canton, OH 44707-2641 USA  
866.RIDEAIR (743.3247)  
330.489.0045 • Fax 800.696.4416

### Hendrickson Canada

250 Chrysler Drive, Unit #3  
Brampton, ON Canada L6S 6B6  
800.668.5360  
905.789.1030 • Fax 905.789.1033

### Hendrickson Mexicana

Circuito El Marqués Sur #29  
Parque Industrial El Marqués  
Pob. El Colorado, Municipio El Marqués,  
Querétaro, México C.P. 76246  
+52 (442) 296.3600 • Fax +52 (442) 296.3601