



# H<sup>®</sup> ASSEMBLY INSTRUCTIONS

## Rotating Bar Pin End Bushing

**SUBJECT:** Kit Number 34013-188L

**LIT NO:** 59310-051

**DATE:** March 2011 **REVISION:** A

### INTRODUCTION

This publication is intended to assist maintenance personnel with the installation of the Rotating Bar Pin End Bushing Kit with shims for any Hendrickson application or suspension where a current 34013-088L or 34013-087L kit is used. This rotating bar pin end bushing requires no special tools to rotate the bar pin bushing after it is pressed into the equalizing beam; a standard shop wrench will rotate the bushing into position with the axle.

This kit can be installed on Hendrickson suspensions equipped with equalizing beams, such as AR2™, R™, RS™, RT™• RTE™, HN®, HAULMAAX® and HAULMAAX® EX.

### BAR PIN END BUSHING INSTRUCTIONS

#### YOU WILL NEED:

- **A shop press** with a capacity of at least 50 tons.
- **Bar pin adapter set** OTC tool# 1757. To order, contact OTC at 507.455.7000 or visit: [www.otctools.com](http://www.otctools.com) for an OTC distributor.
- **Receiving tool** – A shop tool made of steel tubing (4¼" O.D. by 5" length), see Figure 1, which completely supports the beam end hub being serviced and is tall enough to receive the bushing as it is being pressed in or out.

Rotating Bar Pin End Bushing Kit Number 34013-188L	
CONTENTS	
Description	Qty.
Rotating Bar Pin End Bushing	1
Bar Pin Shims	2
Hex Bolts	2
Washers	4
Locknuts	2
<b>NOTE:</b> Two (2) kits per beam or four (4) kits per suspension is required to do a complete re-bush installation.	

**FIGURE 1**

**Bar Pin End Bushing  
Receiving Tool**

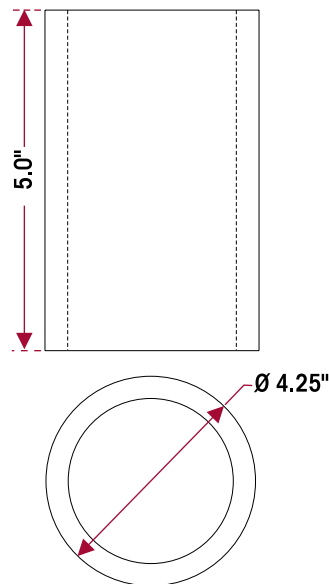

### CAUTION

WHEN REMOVING AND INSTALLING BUSHINGS IN THE EQUALIZING BEAMS, FOLLOW THE PROCEDURES OUTLINED IN THIS PUBLICATION. DO NOT USE A CUTTING TORCH TO REMOVE THE BUSHING OUTER METALS PRESSED IN THE BEAM BORES OR FASTENERS. WELDING, TORCHING OR ATTACHING MATERIAL TO THE EQUALIZING BEAM MUST NEVER BE PERFORMED. THE USE OF HEAT CAN ADVERSELY AFFECT THE STRENGTH OF THE EQUALIZING BEAMS.

### WARNING

DISCARD USED FASTENERS. ALWAYS USE NEW FASTENERS TO COMPLETE A REPAIR. FAILURE TO DO SO COULD RESULT IN FAILURE OF THE PART OR MATING PARTS, LOSS OF VEHICLE CONTROL, PERSONAL INJURY, OR PROPERTY DAMAGE.

### NOTE

Hendrickson recommends the use of Grade 8 bolts, hardened flat washers, and Grade C locknuts. Hardened washers are not necessary when flange head fasteners are used.



## DISASSEMBLY

### CAUTION

FAILURE TO INSTALL THE ALIGNMENT SHIMS IN THE SAME ORIENTATION AND LOCATION AS REMOVED MAY CAUSE VEHICLE MIS-ALIGNMENT. IMPROPER VEHICLE ALIGNMENT CAN INCREASE TIRE WEAR.

### SERVICE HINT

Bar pin alignment shims must be installed in the same orientation and location prior to removal to preserve the existing alignment.

1. Prior to disassembly of the equalizing beam bar pin fasteners, **NOTE** the orientation of the bar pin alignment shims, see Figure 2.
2. Remove the equalizing beam assembly from the vehicle. Refer to the applicable Hendrickson technical publication for your walking beam suspension (available online at [www.hendrickson-intl.com](http://www.hendrickson-intl.com)) regarding the component replacement procedures and safety instructions for the equalizing beam.
3. Place the equalizing beam in the shop press with the beam end hub squarely supported on the receiving tool/press bed.
4. Press on the end bushing inner metal, see Figure 3, of the end bushing until the inner metal is flush with the top of the beam end hub. This will dislodge the confinement washer and move the bushing rubber away from the outer metal of the bushing so the removal tool can be installed.
5. Center the bushing receiving tool directly on the bushing's outer metal and press the bushing out of the beam end hub.
6. After removing the equalizing beam bushings, thoroughly inspect each beam bore.

## INSPECTION

After removing the bar pin end bushings, thoroughly inspect the beam bores. If the equalizing beam is damaged from end bushing removal, replacement of the equalizing beam is required, replace with a new equalizing beam. **DO NOT** rebush or otherwise use an equalizing beam that has been damaged.

### WARNING

FAILURE TO REPLACE AN EQUALIZING BEAM THAT HAS BEEN DAMAGED FROM BUSHING REMOVAL CAN RESULT IN THE FAILURE OF THAT BEAM, LOSS OF VEHICLE CONTROL, POSSIBLE PERSONAL INJURY, OR PROPERTY DAMAGE.

FIGURE 2

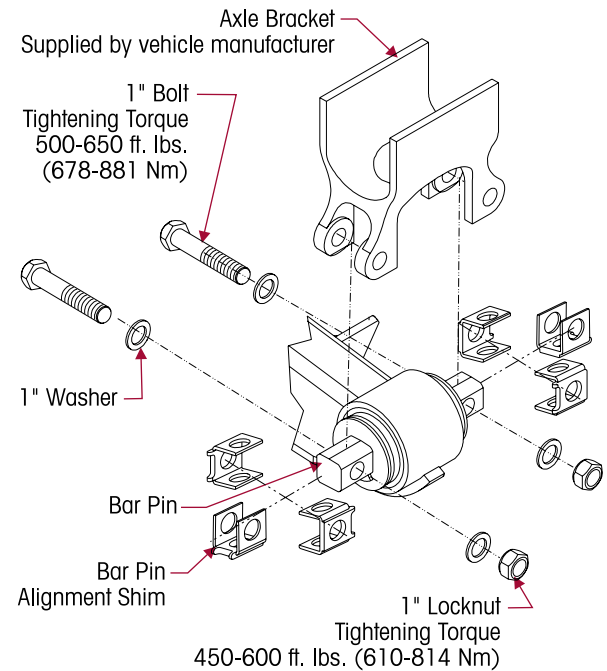
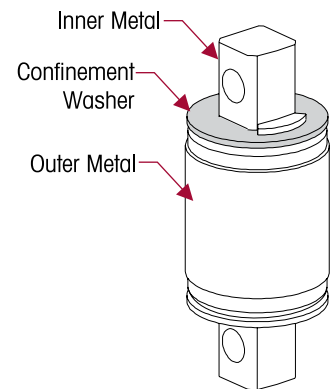

FIGURE 3

### BAR PIN END BUSHING



## PREPARATION

The following steps will help prevent damage to new bar pin bushing during installation:

1. Clean the bores of the equalizing beams with emery cloth or hone, removing any nicks or metal buildup from bushing removal.

**FIGURE 4**

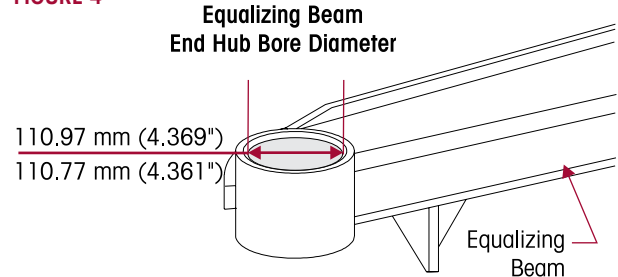

2. Measure the equalizing beam end hub bore inner diameter and the bushing outside diameter. The Hendrickson specification for the equalizing beam end hub bore diameter of equalizing beam is 110.97 mm (4.369") / 110.77 mm (4.361"), see Figure 4. If components are **NOT** within the specified range, replacement is required.

## SERVICE HINT

The equalizing beam bore may have a more substantial lead chamfer at one end of the bore than the other. Take advantage of the larger chamfer by pressing in the new rotating bar pin end bushing from this end.

## ASSEMBLY

1. Place the equalizing beam in a shop press with the end hub (see Figure 5) squarely supported on the receiving tool/press bed.

**FIGURE 5**

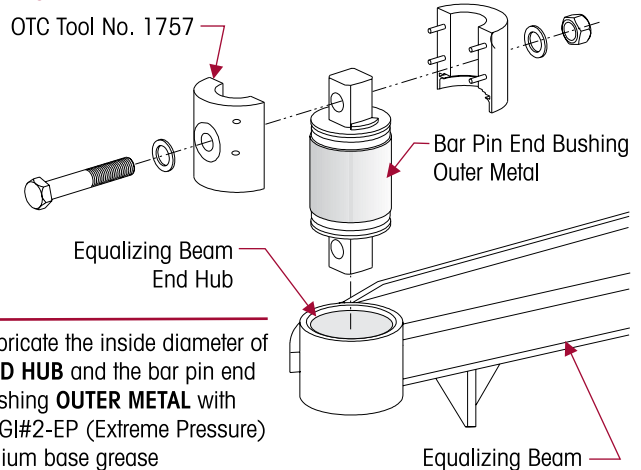

2. Install OTC #1757 end bushing installation tool on the new end bushing as shown in Figure 5. Tighten the through bolt until the two halves of the tool touch. The installation tool compresses the rubber between the inner and outer metal of the bushing to allow press force to be transmitted only to the outer metal of the bushing.
3. Lubricate the equalizing beam end hub inside diameter **AND** the bar pin end bushing's outer metal with a heavy layer of NLGI #2 – EP (Extreme Pressure) lithium base grease, see Figure 5.

## CAUTION

THE END BUSHING MUST BE SQUARE WITH THE EQUALIZING BEAM END HUB BEFORE PRESSING THE END BUSHING INTO THE BEAM. END BUSHINGS PRESSED IN AT AN ANGLE WILL DAMAGE THE END BUSHING AND THE EQUALIZING BEAM.

4. Position the equalizing beam end bushing and installation tool on the end hub.

## CAUTION

CARE MUST BE TAKEN DURING THE INSTALLATION OF THE BUSHING. DO NOT PUSH ON THE INNER METAL OF THE BUSHING, DOING SO WILL CAUSE DAMAGE TO THE BUSHING AND VOID WARRANTY.

5. Verify the end bushing's outer metal is square with the end hub. Equalizing beam and end bushing damage will result if the bushings are not pressed in straight.

6. Install the end bushing into the end hub by pressing on the installation tool until the installation tool contacts the end hub. This will center the bushing in the end hub, see Figure 6.

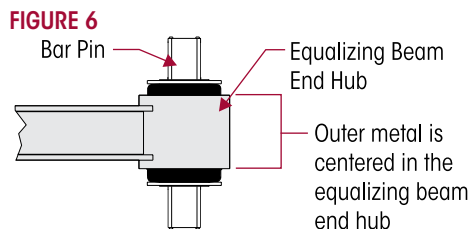

**CAUTION**

FAILURE TO INSTALL THE ALIGNMENT SHIMS IN THE SAME ORIENTATION AND LOCATION AS REMOVED MAY CAUSE VEHICLE MIS-ALIGNMENT. IMPROPER VEHICLE ALIGNMENT CAN INCREASE TIRE WEAR.

7. Bar pin alignment shims **MUST** be installed in the same orientation and location as removed to preserve the existing alignment. A standard shop wrench will rotate the bar pin into position with the axle brackets.
8. Install the equalizing beam assembly into vehicle. Refer to the applicable Hendrickson technical publications for your walking beam suspension available online at [www.hendrickson-intl.com](http://www.hendrickson-intl.com).
9. Bar pin end bushing fasteners must be properly tightened to the specified torque prior to operating the vehicle, see Figure 7.

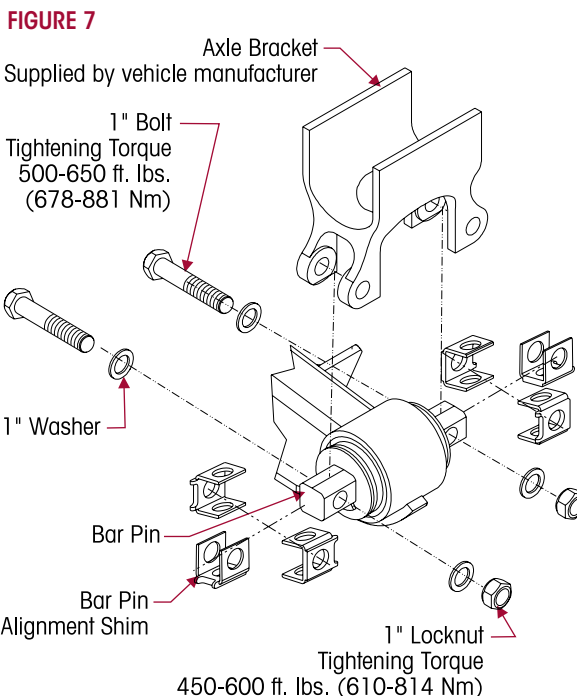

Refer any question regarding this publication to Hendrickson Tech Services.



Toll-free U.S. and Canada  
1.866.755.5968  
Outside U.S. and Canada  
1.630.910.2800



Parts Identification  
[truckparts@hendrickson-intl.com](mailto:truckparts@hendrickson-intl.com)  
Technical Support  
[techservices@hendrickson-intl.com](mailto:techservices@hendrickson-intl.com)



1.630.910.2899



Additional Hendrickson  
Product Information  
[www.hendrickson-intl.com](http://www.hendrickson-intl.com)

Actual product performance may vary depending upon vehicle configuration, operation, service and other factors. All applications must comply with applicable Hendrickson specifications and must be approved by the respective vehicle manufacturer with the vehicle in its original, as-built configuration. Contact Hendrickson for additional details regarding specifications, applications, capacities, and operation, service and maintenance instructions.

Call Hendrickson at **1.866.755.5968** (toll-free) or **1.630.910.2800** for additional information.



[www.hendrickson-intl.com](http://www.hendrickson-intl.com)

**TRUCK COMMERCIAL VEHICLE SYSTEMS**  
800 South Frontage Road  
Woodridge, IL 60517-4904 USA  
1.866.755.5968 (Toll-free U.S. and Canada)  
1.630.910.2800 (Outside U.S. and Canada)  
Fax 1.630.910.2899

59310-051 Rev A 03-11

© 2011 Hendrickson USA, L.L.C. All Rights Reserved. All trademarks shown are owned by Hendrickson USA, L.L.C., or one of the affiliates, in one or more countries. Information contained in this literature was accurate at the time of publication. Product changes may have been made after the copyright date that are not reflected.

Printed in United States of America