



# GENUINE PARTS

## Rear Suspension Conversions

Hendrickson, the leader in suspension technology and the experts in walking beam suspensions, offers conversion kits that deliver reliability and quality through innovative design and advanced manufacturing methods.

**REAR SUSPENSION CONVERSION PROCESS** — Hendrickson can aid you in the selection of a Hendrickson rear suspension kit to meet your vehicle requirements. Suspension conversions, glider kit installations, and custom truck applications are made simple with Hendrickson's suspension conversion kits.

### HAULMAAX®



### COMFORT AIR®



### ULTIMAAX®

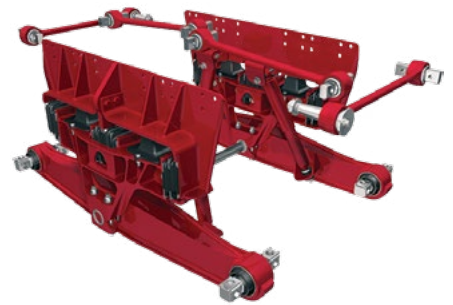

### HN®



### AR2™



### PRIMAAX® EX



### RT™/RTE™

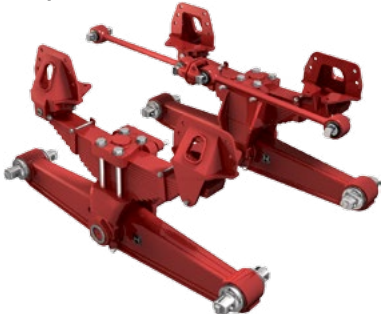

### RS™



### HAS™



To learn more about Hendrickson  
Genuine Parts call 1.866.755.5968  
or visit [www.hendricksonparts.com](http://www.hendricksonparts.com)

 **HENDRICKSON**  
*The World Rides On Us®*

# Rear Suspension Selection Guide

## Air Suspensions

### **AR2™** — Original equipment or aftermarket replacement truck air suspension

- Applications include dump, crane / boom and platform
- Converts most RT™/ RTE™ steel spring suspensions to an air suspension
- Better ride, longer component life, reduced weight, and improved durability
- High articulation capabilities for on- and off-highway applications
- Capacities of 40,000 and 46,000 lbs.



### **HAS™** — Air suspension

- Suited for both on- and off-highway applications
- Large-volume air springs deliver excellent ride quality and cargo protection
- Approved for up to 25 percent off-highway use
- Approved for use with lift axles
- Optional inboard shocks available
- Capacities of 40,000 and 46,000 lbs.



### **COMFORT AIR®** — Single axle, air suspension designed for passenger and driver comfort

- Various medium-duty truck, bus, ambulance and motor home applications
- Wide frame hanger footprint reduces stress to the frame
- Suspension geometry improves ride and handling
- QUIK-ALIGN® axle alignment system simplifies axle alignment
- Capacities ranging from 15,000 to 28,000 lbs.



### **PRIMAAX® EX** — Severe-duty vocational air suspension

- Ideal for dump, logging, refuse, mixer, crane, oil field, military and heavy-haul applications
- Optimized configuration helps improve handling and roll stiffness for expanded applications
- Axle connection and torque rods help reduce torsional axle stress and driveline vibration
- Large-volume, low frequency air springs provide a smooth ride for on- and off-highway use
- Up to 12.5 in. of diagonal wheel articulation for superior mobility
- Capacities of 23,000 and 26,000 lbs. (single), 46,000 and 52,000 lbs. (tandem), and 69,000 and 78,000 lbs. (tridem)





## Walking Beam Suspensions

### **RT/RTE** — Durable steel leaf spring suspension

- Well suited for dump, refuse, mixer and military applications
- Proven reliability for over 90 years
- RTE Series features extended leaf spring for improved unloaded ride quality and loaded stability
- RT capacities up to 65,000 lbs. and RTE capacities up to 50,000 lbs.

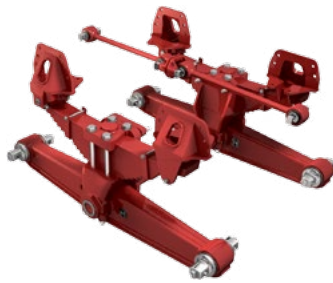

### **R™/RS™** — Severe-service suspensions

- Exceptional performance in mining, oil field, mixer, refuse, logging and other specialty applications
- R series solid mount is an extra heavy-duty suspension where maximum roll stability is essential
- RS rubber load cushions absorb shock and provide high stability for severe-service applications
- Capacities up to 120,000 lbs.



### **ULTIMAAX®** — Advanced severe-duty rubber suspension

- Recommended for dump, logging, refuse, mixer, oil field and mining applications
- Optimized design to balance robust durability and weight savings
- Progressive rate springs provide a unique balance of unloaded ride quality and loaded stability
- Fabricated walking-beam design equalizes axle loading while providing optimal clearance, axle travel and weight
- Capacities up to 60,000 lbs. with additional capacities under development

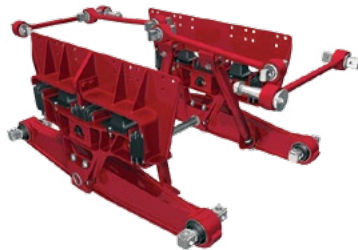

### **HAULMAAX®** — Heavy-duty lightweight rubber suspension

- Recommended for dump, refuse, mixer, logging and military applications
- Provides superior combination of empty ride and loaded stability
- Reduced maintenance with fewer bushings and no lubrication requirements
- Up to 17 in. of diagonal articulation for greater off-highway mobility
- Capacities of 40,000 and 46,000 lbs.



### **HN®** — Heavy-duty rubber suspension

- Applications include dump, refuse, mixer, logging and military
- VARIRATE® system provides excellent loaded stability and unloaded ride quality
- Up to 17 in. of diagonal articulation contributes to outstanding traction
- Reduced maintenance with fewer bushings and no lubrication requirements
- Capacities of 40,000, 46,000 and 52,000 lbs.



**Not included in Rear Suspension Aftermarket Kits** – Axle beam hangers and torque rod axle brackets (supplied by the respective vehicle manufacturer).

# Suspension Conversions — Truck Commercial Vehicle Systems

## SUSPENSION PERFORMANCE RATING\*

	AR2	COMFORT AIR	HAS	PRIMAAX EX	HAULMAAX	HN	RT	RTE	R	RS	ULTIMAAX
Ride Quality— Loaded	9	10	10	10	8	8	7	7	5	5	8
Ride Quality—Unloaded	9	10	10	10	8	8	5	7	3	3	8
Mobility/Articulation	9	6	5	9	10	10	9	9	9	9	9
Stability Off-Highway	5	6	6	8	9	9	7	7	9	9	8
Durability	8	5	5	9	9	9	10	10	10	10	9

### RATING SCALE

**Ride Quality** — describes how well the suspension absorbs road shock as the truck encounters bumps, potholes, and other road irregularities.

- 9-10** Minimal bounce, fore/aft, and lateral movement
- 7-8** Some bounce, fore/aft, and lateral movement
- 3-6** Regular bounce, fore/aft, and lateral movement

**Mobility/Articulation** — describes how well the suspension provides traction and maneuverability, especially the ability to maneuver over obstacles and avoid getting stuck.

- 9-10** Loaded diagonal articulation is greater than 12"
- 7-8** Loaded diagonal articulation is 8"-12"
- 5** Loaded diagonal articulation is 7"

**Stability Off-Highway** — describes how well the suspension resists vehicle leaning in lower speed operations on job sites, particularly during loading and unloading.

- 9-10** Comfortable to maneuver across most grades on typical job sites
- 7-8** Comfortable to maneuver across moderate grades on typical job sites
- 5-6** Comfortable to maneuver across level ground and shallow grade

**Durability** — describes the ability of a suspension to withstand rigorous operation over the life of the vehicle.

- 9-10** Designed for more than 50% off-highway operation fully loaded
- 7-8** Designed for 30-50% off-highway operation fully loaded
- 4-6** Designed for 15-30% off-highway operation

\* These ratings are intended for reference and comparison purposes only, and are not based on actual measurements. Actual product performance may vary depending upon vehicle configuration, operation, service and other factors.

## ORDER PROCESS

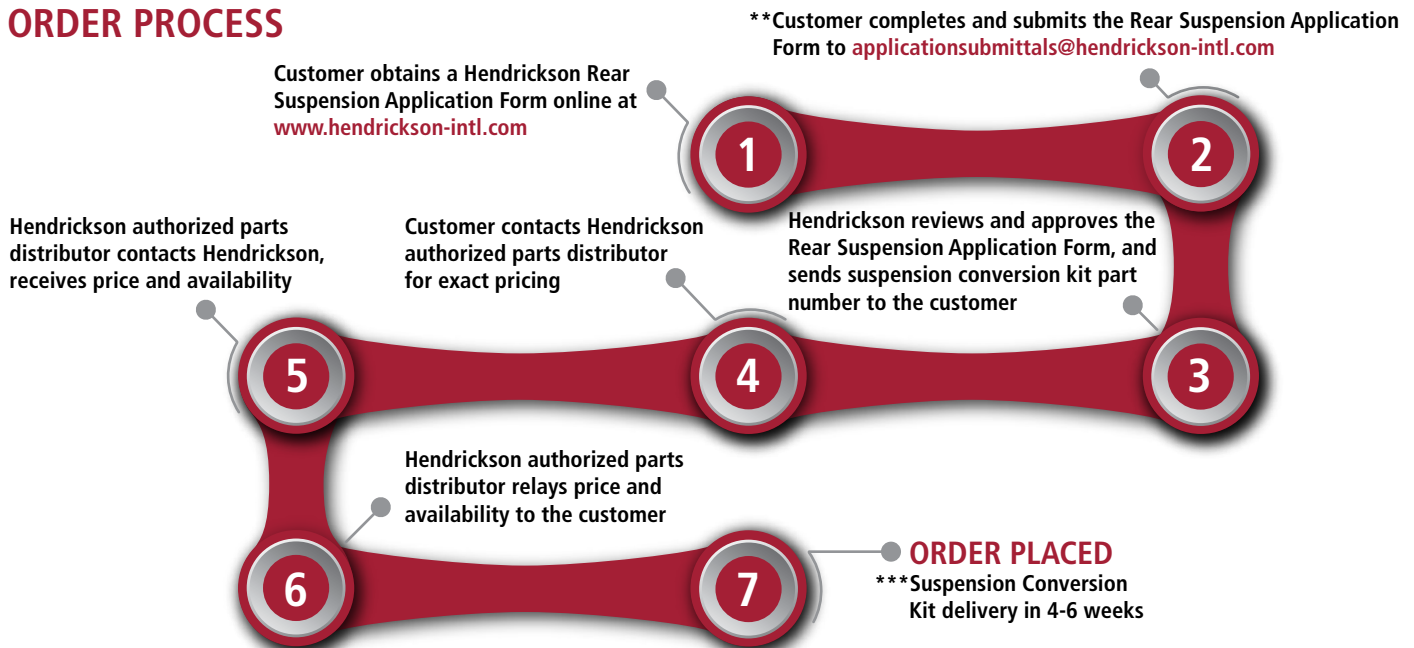

\*\* For questions contact [truckparts@hendrickson-intl.com](mailto:truckparts@hendrickson-intl.com)

\*\*\* Rush delivery – if available, may be subject to additional charges for special services, which include, but not limited to, expedited delivery and additional freight costs. Please contact Hendrickson for more details on these services.

Call your truck dealer or Hendrickson at **1.866.755.5968 (toll-free)** or **1.630.910.2800** for additional information.



[www.hendrickson-intl.com](http://www.hendrickson-intl.com)

### TRUCK COMMERCIAL VEHICLE SYSTEMS

800 South Frontage Road  
Woodridge, IL 60517-4904 USA  
1.866.755.5968 (Toll-free U.S. and Canada)  
1.630.910.2800 (Outside U.S. and Canada)  
Fax 1.630.910.2899