

H OWNER'S MANUAL

HAC Air Kits

SUBJECT: Installation, Maintenance and
Operation Procedures

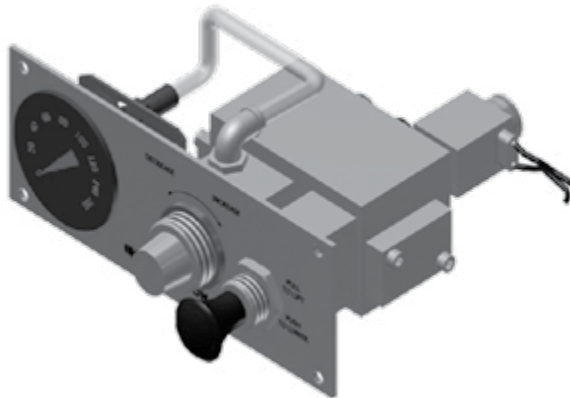
LIT NO: OM-H719

DATE: August 2018

REVISION: D

TABLE OF CONTENTS

Section 1	Introduction	2	Section 7	Suspension Operation	
Section 2	Product Description	2		Raising your Lift Axle	16
Section 3	Important Safety Notice	4		Lowering your Lift Axle	16
Section 4	HAC Air Kit Components	8	Section 8	Preventive Maintenance	
Section 5	Installation			Hendrickson Recommended	
	Installation Instructions	11		Maintenance Intervals	17
	Installation Tips	12	Section 9	Tech Tips	17
Section 6	Plumbing & Wiring Diagram	13	Section 10	Frequently Asked Questions	18
			Section 11	Troubleshooting Guide	19



SECTION 1

Introduction

This publication is intended to acquaint and assist personnel with the installation, service, maintenance, and operation of Hendrickson HAC Air Kits on vehicles equipped with Hendrickson Auxiliary Lift Axle Suspensions.

NOTE	<p>Use only Hendrickson Genuine Parts for servicing this suspension system.</p> <p>It is important to read and understand this entire publication prior to performing any installation, service, maintenance, and operation of the product. The information in this publication contains product images, safety information, product specifications, features and instructions for proper installation, service, maintenance, and operation of Hendrickson HAC Air Kits.</p> <p>Hendrickson reserves the right to make changes and improvements to its products and publications at any time. Contact Hendrickson Tech Services for information on the latest version of this manual at 1-800-660-2829 (toll-free U.S. and Canada), 1-740-929-5600 (Outside U.S. and Canada), or e-mail: liftaxle@hendrickson-intl.com.</p> <p>The latest revision of this publication is also available online at www.hendrickson-intl.com.</p>
-------------	--

SECTION 2

Product Description

HAC SERIES LIFT AXLE CONTROLS are designed to accommodate a variety of lift axle applications and lift axle control requirements. The controllers are made up of a pneumatic valve assembly that is packaged together with a pressure regulator, dial indicator gauge, and push / pull knob. The regulator controls the pressure in the lift axle ride bags. The dial indicator reports the pressure the regulator is set to. The push / pull knob controls the state of the lift axle, either deployed or retracted. The kits are differentiated by the position of components and a variety of additional components which optimize the system to meet a variety of lift axles, regulations, and chassis requirements. One air kit is required per lift axle.

Refer to Table 2-1 to review the standard lift axle Air Control Kits categorized by the control mounting location and lift axle application.

NOTE	State / Provincial law regulates the mounting location for the lift axle controls. Refer to the Department of Transportation requirements for the state or province that the vehicle will be operating in prior to selecting a control. Maryland has specific requirements that the HAC-MSO was specifically designed to meet.
-------------	---

TABLE 2-1

AIR CONTROL KITS

		INSIDE-MOUNTED	OUTSIDE-MOUNTED (COMPOSITE)	OUTSIDE-MOUNTED (STAINLESS)
LIFT AXLE APPLICATION	Steerable	HAC-SSI	HAC-UCO	HAC-USO
	Non-Steerable	HAC-NSI	HAC-UCO	HAC-USO
	Reverse Lift & Lock	HAC-LSI	HAC-LCO	HAC-LSO
	Reverse Down & Lock	HAC-RSI	HAC-RCO	HAC-RSO
	Reverse Caster	HAC-ASI	HAC-ACO	HAC-ASO

HAC Series Lift axle controls designed for steerable axles include a **Solenoid Valve** that can be wired to provide lift in reverse functionality. Steerable axles must be lifted when moving in reverse or locked from turning to prevent damage to the axle / suspension. Steerable axles including a lock straight feature require additional components found in the kits from the Reverse Lift & Lock or Reverse Down & Lock rows of Table 2-1. Steerable axles designed to be able to reverse their caster angle and steer in reverse require additional components found in the kits from the Reverse Caster row of Table 2-1.

Outside-Mounted **HAC Series** lift axle controls are also included with an **Electric Override Switch**. The **Electric Override Switch** is intended to be installed in the cab to give drivers temporary override control without exiting the vehicle. When the override switch is powered **ON** it will override the push / pull knob position on controller to temporarily lift the axle. When the switch (or vehicle) is powered **OFF** the axle will redeploy to match the state of the push / pull knob in the control box. Lift in reverse functionality is maintained using the relay provided in the kit. Outside-Mounted lift axle controls are also offered in either a composite plastic or stainless steel package.

Exceptions include the following. Refer to Hendrickson customer service for additional information.

- **HAC-MCA kit** – For steerable or non-steer axles. An outside-mounted composite enclosure containing the valve assembly, regulator and gauge. A separate **Electric Switch** is intended to be mounted in the cab to control the state of the axle. This kit does not include a push / pull knob. This kit also provides lift in reverse functionality. The HAC-MCA is designed to lift the axle automatically upon turning the truck off.
- **HAC-DSI Kit** – For certain tag axle applications on chassis with Power Take-off (PTO). An inside-mounted steel enclosure containing the valve assembly, two (2) regulators and two (2) gauges for controlling one (1) lift axle. A separate **Electric Switch** is intended to be mounted in the cab to control the state of the axle. One (1) regulator controls the normal running pressure of the lift axle ride bags and the second can be set to control the lift axle ride bags to an alternate pressure when the system senses a PTO is powered on.

STANDARD COMPONENTS

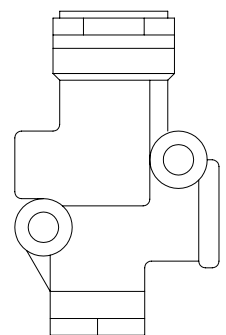
All air kits come standard with one (1) Pressure protection valve, one (1) Quick-Exhaust valve and one (1) In-line filter for a single lift axle application.

OPTIONAL COMPONENTS

The following options will facilitate or enhance the installation and the operation of your air kit:

- **Brake Release Valve** – **Part No. R-001994**, A pilot valve used to allow auxiliary lift axle brakes, to apply normally when the suspension is in the **DOWN** position. However, when the auxiliary lift axle is in the **UP** position, the brakes are released to eliminate hang-ups during high centering and to conserve system air pressure, see Figure 2-1.
- **Mounting Bracket** – A single, double or L-shape mounting bracket designed to mount a HAC-SSI or HAC-NSI panel inside the cab, refer to Figure 4-3.
- **Quick-Exhaust Valve** – Two (2) pieces of **Part No. R-004348** can mount to the ride spring air inlet port as an alternate or addition to the Quick-Exhaust valve included in the kit, R-004348-1.

FIGURE 2-1
Brake Release Valve
R-001994



SECTION 3

Important Safety Notice

Proper maintenance, service, and repair is important for the reliable operation of the suspension. The procedures recommended by Hendrickson and described in this technical publication are methods of performing such maintenance, service and repair.

All safety-related information should be read carefully to help prevent personal injury and to assure that proper methods are used. Improper servicing may damage the vehicle, cause personal injury, render it unsafe for operation, or void manufacturer's warranty.

Failure to follow the safety precautions in this manual can result in personal injury and / or property damage. Carefully read and understand all safety related information within this publication, on all decals and in all such materials provided by the vehicle manufacturer before conducting any maintenance, service or repair.

■ EXPLANATION OF SIGNAL WORDS

Hazard "Signal Words" (Danger-Warning-Caution) appear in various locations throughout this publication. Information accented by one of these signal words must be observed to help minimize the risk of personal injury to service personnel, or the possibility of improper service methods, which may damage the vehicle or render it unsafe.



This is the safety alert symbol. It is used to alert you to potential personal injury hazards. Obey all safety messages that follow this symbol to avoid possible injury or death.

Additional Notes or Service Hints are utilized to emphasize areas of procedural importance and provide suggestions for ease of repair. The following definitions indicate the use of these signal words as they appear throughout the publication.

DANGER

INDICATES AN IMMINENTLY HAZARDOUS SITUATION, WHICH, IF NOT AVOIDED, WILL RESULT IN SERIOUS INJURY OR DEATH.

WARNING

INDICATES A POTENTIAL HAZARDOUS SITUATION, WHICH, IF NOT AVOIDED, CAN RESULT IN SERIOUS INJURY OR DEATH.

CAUTION

INDICATES A POTENTIAL HAZARDOUS SITUATION, WHICH, IF NOT AVOIDED, MAY RESULT IN MINOR OR MODERATE INJURY.

NOTE

An operating procedure, practice condition, etc. which, is essential to emphasize.

SERVICE HINT

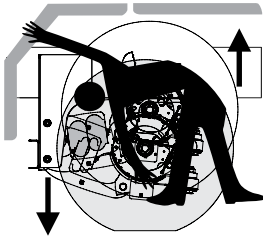
A helpful suggestion that will make the servicing being performed a little easier and / or faster.



The torque symbol alerts you to tighten fasteners to a specified torque value. Refer to Torque Specifications section of this publication.

■ SAFETY PRECAUTIONS

WARNING



LIFT AXLE RAPID MOVEMENT

LIFT AXLE RAPID MOVEMENT CAN CAUSE SEVERE PERSONAL INJURY OR DEATH.

IF LIFT AXLE IS OPERATED BY AN AUTOMATIC OR SEMI-AUTOMATIC LIFT AXLE CONTROL SYSTEM, SUCH SYSTEM MAY CAUSE LIFT AXLE TO AUTOMATICALLY RAISE OR LOWER UNDER DIFFERENT CONDITIONS.

LIFT AXLE ACTIVATION AND MOVEMENT MAY VARY DEPENDING ON THE BRAND, CONFIGURATION, AND OPERATING CONDITION OF THE LIFT AXLE CONTROL SYSTEM AND / OR OTHER FACTORS. READ, UNDERSTAND, AND COMPLY WITH ALL APPLICABLE OPERATING INSTRUCTIONS AND SAFETY INFORMATION PROVIDED BY THE LIFT AXLE CONTROL SYSTEM MANUFACTURER AND VEHICLE MANUFACTURER.

ENSURE ALL PERSONNEL ARE CLEAR OF LIFT AXLE BEFORE AND DURING VEHICLE LOADING AND LIFT AXLE ACTIVATION UP OR DOWN.

CAUTION

LIFT AXLE ACTIVATION

DO NOT LOWER LIFT AXLE WHILE THE VEHICLE IS MOVING IN REVERSE OR TRAVELING AT MORE THAN 15 MPH. FAILURE TO DO SO CAN CAUSE COMPONENT DAMAGE.

CAUTION

REVERSE LOCKOUT OPERATION

DO NOT ACTUATE STEERABLE LIFT AXLE REVERSE LOCKOUT FEATURE (IF EQUIPPED) WHILE VEHICLE IS TURNING. FAILURE TO DO SO CAN CAUSE COMPONENT DAMAGE.

BEFORE TRAVELING IN REVERSE:

- ENSURE STEERABLE LIFT AXLE REVERSE LOCKOUT FEATURE (IF EQUIPPED) IS PROPERLY ACTUATED.
- RAISE ALL STEERABLE LIFT AXLES NOT EQUIPPED WITH REVERSE LOCKOUT FEATURE.

FAILURE TO DO SO CAN CAUSE COMPONENT DAMAGE.

CAUTION

REVERSE CASTER OPERATION

DO NOT LOWER STEERABLE LIFT AXLE EQUIPPED WITH REVERSE CASTER FEATURE WHILE VEHICLE IS MOVING IN REVERSE. FAILURE TO DO SO CAN CAUSE COMPONENT DAMAGE.

WARNING

LOAD CAPACITY

ADHERE TO THE PUBLISHED CAPACITY RATINGS FOR THE AUXILIARY AXLES. ADD-ON AXLE ATTACHMENTS (I.E. SLIDING FIFTH WHEELS) AND OTHER LOAD TRANSFERRING DEVICES CAN INCREASE THE AUXILIARY AXLES LOAD ABOVE THE RATED AND APPROVED CAPACITIES WHICH CAN RESULT IN FAILURE AND ADVERSE VEHICLE HANDLING, POSSIBLY CAUSING PERSONAL INJURY OR PROPERTY DAMAGE.

CAUTION

DAILY / PRE-TRIP OPERATOR INSPECTION

DAILY (AND BEFORE EACH TRIP) INSPECT ALL LIFT AXLE COMPONENTS FOR PROPER OPERATING CONDITION AND PROPER INSTALLATION TO THE TRUCK / TRAILER FRAME. THIS ESSENTIAL **DAILY / PRE-TRIP OPERATOR INSPECTION** MUST ALSO INCLUDE A VISUAL INSPECTION OF ALL WHEEL SEALS AND GASKETS FOR LEAKS, A VERIFICATION OF PROPER OIL LEVEL IN THE HUBS (IF APPLICABLE), INSPECTION OF ALL LIFT AND RIDE AIR-SPRINGS FOR WEAR, AND INSPECTION OF ALL TIRES FOR PROPER INFLATION AN ABNORMAL WEAR PATTERNS. IDENTIFY AND REPAIR / REPLACE ANY LOOSE, DAMAGED OR IMPROPERLY INSTALLED COMPONENTS. REFER TO THE CURRENT VERSION OF HENDRICKSON PUBLICATION NO. TP-H621 FOR ADDITIONAL SERVICE, REPAIR, AND REBUILD INSTRUCTIONS.

WARNING

REPAIR AND RECONDITIONING

THE REPAIR OR RECONDITIONING OF AUXILIARY AXLE COMPONENTS THAT ARE BENT, DAMAGED OR OUT OF SPECIFICATION IS NOT ALLOWED. ANY AXLE COMPONENTS FOUND TO BE DAMAGED OR OUT OF SPECIFICATION, MUST BE REPLACED. AXLE COMPONENTS CANNOT BE BENT, WELDED, HEATED, OR REPAIRED WITHOUT REDUCING THE STRENGTH OR LIFE OF THE COMPONENT. FAILURE TO FOLLOW THESE GUIDELINES CAN CAUSE ADVERSE VEHICLE HANDLING, POSSIBLE PERSONAL INJURY, DEATH, OR PROPERTY DAMAGE AND WILL VOID APPLICABLE WARRANTIES.

⚠ WARNING**AIR SPRINGS**

PRIOR TO AND DURING DEFLATION AND INFLATION OF THE AIR SUSPENSION SYSTEM, ENSURE THAT ALL PERSONNEL AND EQUIPMENT ARE CLEAR FROM UNDER THE VEHICLE AND AROUND THE SERVICE AREA, FAILURE TO DO SO CAN CAUSE SEVERE PERSONAL INJURY, DEATH, OR PROPERTY DAMAGE.

⚠ WARNING**AIR SPRINGS**

EXHAUST ALL PRESSURE IN LIFT AXLE AIR SPRINGS AND VEHICLE AIR SYSTEM BEFORE WORKING ON OR AROUND LIFT AXLE. FAILURE TO DO SO CAN CAUSE SEVERE PERSONAL INJURY OR DEATH.

⚠ CAUTION**AIR SPRINGS**

INFLATE THE SUSPENSION SLOWLY AND MAKE SURE THE RUBBER BLADDER OF THE AIR SPRING INFLATES UNIFORMLY AND IS NOT BINDING. FAILURE TO DO SO CAN CAUSE DAMAGE TO THE AIR SPRING AND / OR MOUNTING BRACKETS AND WILL VOID APPLICABLE WARRANTIES.

⚠ WARNING**AIR SPRINGS**

AIR SPRING ASSEMBLIES MUST BE DEFLATED PRIOR TO LOOSENING ANY ADJACENT HARDWARE. UNRESTRICTED AIR SPRING ASSEMBLIES CAN VIOLENTLY SHIFT. DO NOT INFLATE AIR SPRING ASSEMBLIES WHEN THEY ARE UNRESTRICTED. AIR SPRING ASSEMBLIES MUST BE RESTRICTED BY SUSPENSION OR OTHER ADEQUATE STRUCTURE. DO NOT INFLATE BEYOND PRESSURES RECOMMENDED BY AIR SPRING MANUFACTURER. CONTACT HENDRICKSON TECHNICAL SERVICES FOR DETAILS. IMPROPER USE OR OVER INFLATION MAY CAUSE AIR SPRING ASSEMBLIES TO BURST, CAUSING PROPERTY DAMAGE AND / OR SEVERE PERSONAL INJURY.

⚠ WARNING**FASTENERS**

DISCARD USED FASTENERS. ALWAYS USE NEW FASTENERS TO COMPLETE A REPAIR. FAILURE TO DO SO COULD RESULT IN FAILURE OF THE PART OR MATING COMPONENTS, ADVERSE VEHICLE HANDLING, PERSONAL INJURY, OR PROPERTY DAMAGE.

LOOSE OR OVER-TORQUED FASTENERS CAN CAUSE COMPONENT DAMAGE, ADVERSE VEHICLE HANDLING, PROPERTY DAMAGE, OR SEVERE PERSONAL INJURY. MAINTAIN CORRECT TORQUE VALUE AT ALL TIMES. CHECK TORQUE VALUES ON A REGULAR BASIS AS SPECIFIED, USING A REGULARLY CALIBRATED TORQUE WRENCH. TORQUE VALUES SPECIFIED IN THIS TECHNICAL PUBLICATION ARE FOR HENDRICKSON SUPPLIED FASTENERS ONLY. IF NON-HENDRICKSON FASTENERS ARE USED, FOLLOW TORQUE SPECIFICATIONS LISTED IN THE VEHICLE MANUFACTURER'S SERVICE MANUAL.

⚠ WARNING**MODIFYING COMPONENTS**

DO NOT MODIFY OR REWORK PARTS WITHOUT AUTHORIZATION FROM HENDRICKSON. DO NOT SUBSTITUTE REPLACEMENT COMPONENTS NOT AUTHORIZED BY HENDRICKSON. USE OF MODIFIED, REWORKED, SUBSTITUTE OR REPLACEMENT PARTS NOT AUTHORIZED BY HENDRICKSON MAY NOT MEET HENDRICKSON'S SPECIFICATIONS, AND CAN RESULT IN FAILURE OF THE PART, ADVERSE VEHICLE HANDLING, POSSIBLE PERSONAL INJURY OR PROPERTY DAMAGE, AND WILL VOID APPLICABLE WARRANTIES. USE ONLY HENDRICKSON-AUTHORIZED REPLACEMENT PARTS.

THE VEHICLE MANUFACTURER SHOULD BE CONSULTED BEFORE MAKING ANY CHANGES TO THE VEHICLE'S FRAME. TYPICALLY, CUTTING OR ALTERING THE VEHICLE'S FRAME OR SIDE RAIL IS NOT PERMITTED AND MAY AFFECT THE MANUFACTURER'S WARRANTY COVERAGE.

ANY INSTALLATION DEVIATIONS MUST BE APPROVED IN WRITING BY HENDRICKSON'S PRODUCT ENGINEERING DEPARTMENT. FAILURE TO COMPLY WITH ANY OF THE ABOVE WILL VOID APPLICABLE WARRANTIES.

⚠ WARNING**IMPROPER JACKING METHOD**

IMPROPER JACKING METHOD CAN CAUSE STRUCTURAL DAMAGE AND RESULT IN ADVERSE VEHICLE HANDLING, SEVERE PERSONAL INJURY OR DEATH. DO NOT USE AXLE BEAM OUTBOARD OF AXLE SPRING SEATS. REFER TO VEHICLE MANUFACTURER FOR PROPER JACKING INSTRUCTIONS.

⚠ WARNING**OFF ROADWAY TOWING**

HENDRICKSON DOES NOT RECOMMEND TOWING A VEHICLE BY THE AUXILIARY AXLE. DOING SO WILL DAMAGE THE AXLE AND WILL VOID APPLICABLE WARRANTIES.

⚠ CAUTION**PROCEDURES AND TOOLS**

A MECHANIC USING A SERVICE PROCEDURE OR TOOL, THAT HAS NOT BEEN RECOMMENDED BY HENDRICKSON, MUST FIRST SATISFY HIMSELF THAT NEITHER HIS SAFETY NOR THE VEHICLE'S SAFETY WILL BE JEOPARDIZED BY THE METHOD OR TOOL SELECTED. INDIVIDUALS DEVIATING IN ANY MANNER FROM THE INSTRUCTIONS PROVIDED ASSUME ALL RISKS OF POTENTIAL PERSONAL INJURY OR DAMAGE TO EQUIPMENT INVOLVED.

⚠ WARNING**PERSONNEL PROTECTIVE EQUIPMENT**

ALWAYS WEAR PROPER EYE PROTECTION AND OTHER REQUIRED PERSONAL PROTECTIVE EQUIPMENT TO HELP PREVENT PERSONAL INJURY WHEN YOU PERFORM VEHICLE MAINTENANCE, REPAIR OR SERVICE.

⚠ WARNING**DAMAGED AXLE COMPONENTS**

IF A VEHICLE EQUIPPED WITH A HENDRICKSON AUXILIARY AXLE IS INVOLVED IN A CRASH, A THOROUGH INSPECTION OF THE AXLE MUST BE PERFORMED NOTING THE CONDITION OF THE AXLE BEAM, KINGPINS, AND KNUCKLE ASSEMBLIES, INCLUDING THE AREAS OF AXLE-TO-KINGPIN INTERFACE, FOR ANY DAMAGE, GAPS, KINGPIN MOVEMENT OR PLAY. IF ANY COMPONENT APPEARS DAMAGED, OR THE KINGPINS APPEAR TO CONTAIN ANY DAMAGE, GAPS, MOVEMENT OR PLAY, THE COMPLETE AXLE ASSEMBLY MUST BE REPLACED.

IN ADDITION, IN THE EVENT A CRASH RESULTS IN EXCESSIVE SIDE LOAD DAMAGE TO ADJACENT PARTS, SUCH AS A BENT WHEEL, HUB, OR SPINDLE, IT IS STRONGLY RECOMMENDED TO REPLACE SUCH ADJACENT PARTS AND THE COMPLETE AXLE ASSEMBLY.

CONTACT HENDRICKSON TECHNICAL SERVICES DEPARTMENT WITH ANY QUESTIONS. FAILURE TO REPLACE ANY DAMAGED COMPONENTS CAN CAUSE ADVERSE VEHICLE HANDLING, POSSIBLE PERSONAL INJURY, DEATH, OR PROPERTY DAMAGE AND WILL VOID ANY APPLICABLE WARRANTIES.

⚠ WARNING**SUPPORT THE VEHICLE PRIOR TO SERVICING**

PLACE THE VEHICLE ON A LEVEL FLOOR AND CHOCK THE WHEELS TO HELP PREVENT THE VEHICLE FROM MOVING. PRIOR TO SERVICING A VEHICLE IN THE RAISED POSITION, PROPERLY SUPPORT THE VEHICLE WITH SAFETY STANDS. DO NOT WORK AROUND OR UNDER A RAISED VEHICLE SUPPORTED ONLY WITH FLOOR JACKS OR OTHER LIFTING DEVICES, FAILURE TO DO SO CAN CAUSE DEATH, PERSONAL INJURY OR DAMAGE TO COMPONENTS.

⚠ WARNING**SUPPORT THE LIFT AXLE PRIOR TO SERVICING**

PLACE THE VEHICLE ON A LEVEL FLOOR AND CHOCK THE WHEELS TO HELP PREVENT THE VEHICLE FROM MOVING. PRIOR TO SERVICING A LIFT AXLE IN THE RAISED POSITION, (1) PROPERLY SUPPORT THE LIFT AXLE WITH SAFETY STANDS, AND (2) RELEASE ALL AIR PRESSURE IN THE LIFT AXLE AIR SPRINGS AND RIDE SPRINGS. DO NOT WORK AROUND OR UNDER A RAISED LIFT AXLE SUPPORTED ONLY WITH FLOOR JACKS OR OTHER LIFTING DEVICES, FAILURE TO DO SO CAN CAUSE DEATH, PERSONAL INJURY OR DAMAGE TO COMPONENTS.

⚠ WARNING**PARTS CLEANING**







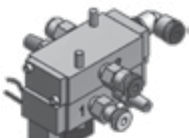




SOLVENT CLEANERS CAN BE FLAMMABLE, POISONOUS, AND CAUSE BURNS. TO HELP AVOID SERIOUS PERSONAL INJURY, CAREFULLY FOLLOW THE MANUFACTURER'S PRODUCT INSTRUCTIONS AND GUIDELINES AND THE FOLLOWING PROCEDURES:

1. WEAR PROPER EYE PROTECTION.
2. WEAR CLOTHING THAT PROTECTS YOUR SKIN.
3. WORK IN A WELL VENTILATED AREA.
4. DO NOT USE GASOLINE OR SOLVENTS THAT CONTAIN GASOLINE. GASOLINE CAN EXPLODE.
5. HOT SOLUTION TANKS OR ALKALINE SOLUTIONS MUST BE USED CORRECTLY. FOLLOW THE MANUFACTURER'S RECOMMENDED INSTRUCTIONS AND GUIDELINES CAREFULLY TO HELP PREVENT PERSONAL ACCIDENT OR INJURY.

DO NOT USE HOT SOLUTION TANKS OR WATER AND ALKALINE SOLUTIONS TO CLEAN GROUND OR POLISHED PARTS. DOING SO WILL CAUSE DAMAGE TO THE PARTS AND VOID APPLICABLE WARRANTIES.

SECTION 4 HAC Air Kit Components

TABLE 4-1
HAC AIR KITS COMPONENTS

		HAC-SSI	HAC-NSI	HAC-LSI	HAC-RSI	HAC-ASI	HAC-UCO / USO	HAC-LCO / LSO	HAC-RCO / RSO	HAC-ACO / ASO	HAC-MCA	HAC-MSO
	Inside-Mounted <i>See Figure 4-3 for bracket options.</i>	X	X	X	X	X						
	Outside-Mounted Composite Box						X	X	X	X	X*	
	Outside-Mounted Stainless Box											
	Outside-Mounted Composite Box Maryland											X
	Reverse Down & Lock Valve R-009790-1				X				X			
	Reverse Lift & Lock Valve R-009790			X				X				
	Reverse Caster Valve R-010028					X				X		
	Electric Override Switch R-009791						X	X	X	X	X	X
	Quick-Exhaust Valve R-004348-1	X	X	X	X	X	X	X	X	X	X	X
	Pressure Protection Valve R-009689	X	X	X	X	X	X	X	X	X	X	X
	In-line Filter R-013282	X	X	X	X	X	X	X	X	X	X	X

* May appear different than shown.

FIGURE 4-1
HAC REPLACEMENT PARTS

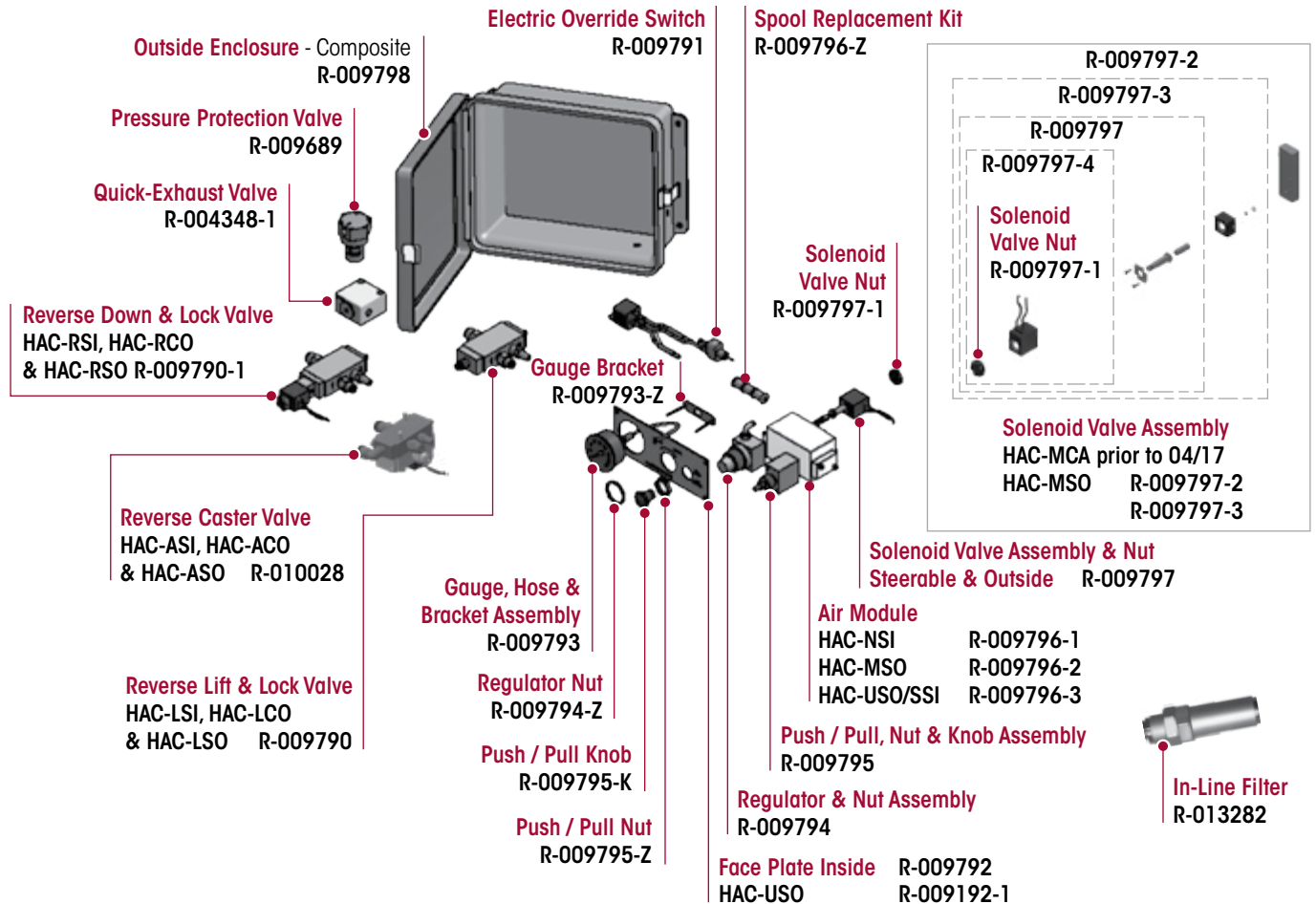
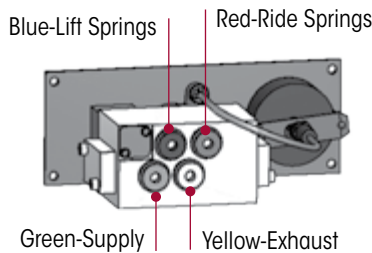


FIGURE 4-2
INSIDE-MOUNTED AND OUTSIDE-MOUNTED CONTROLLERS

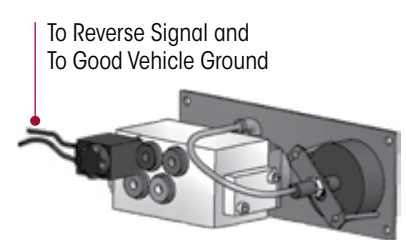
Inside-Mounted Front View
HAC-SSI, NSI, LSI, RSI, ASI



Inside-Mounted Back View
Non-steerable HAC-NSI



Inside-Mounted Back View
Steerable HAC-SSI



Outside-Mounted Composite Box (Maryland Specification)
HAC-MSO - Includes schrader valve to verify air pressure



Outside-Mounted Composite Box
HAC-UCO, LCO, RCO & ACO
HAC-USO, LSO, RSO & ASO

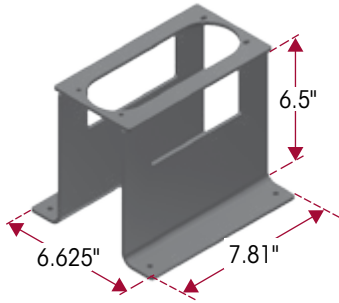


Outside-Mounted Stainless Box
HAC-UCO, LCO, RCO & ACO
HAC-USO, LSO, RSO & ASO

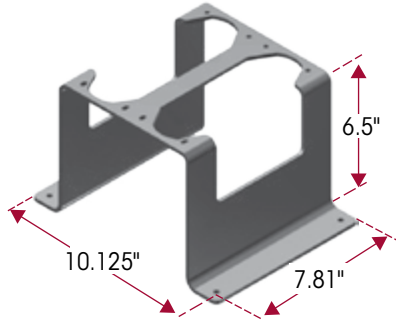


FIGURE 4-3
OPTIONAL COMPONENTS

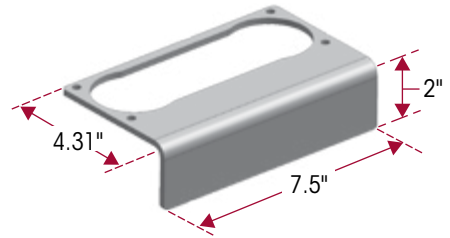
Single-panel Mount Bracket R-009800-1
For inside the cab



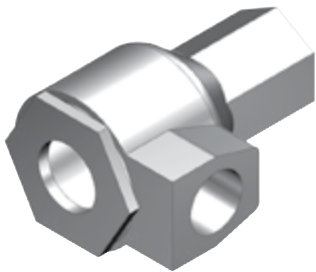
Double-panel Mount Bracket R-009800-2
For inside the cab



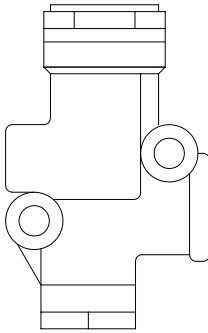
L-shape Panel Mount Bracket R-005771
For mounting the control panel on the side of the center console box (Single Panel application only)



Quick-Exhaust Valve R-004348
Two (2) used per axle



Brake Release Valve R-001994



SECTION 5 Installation

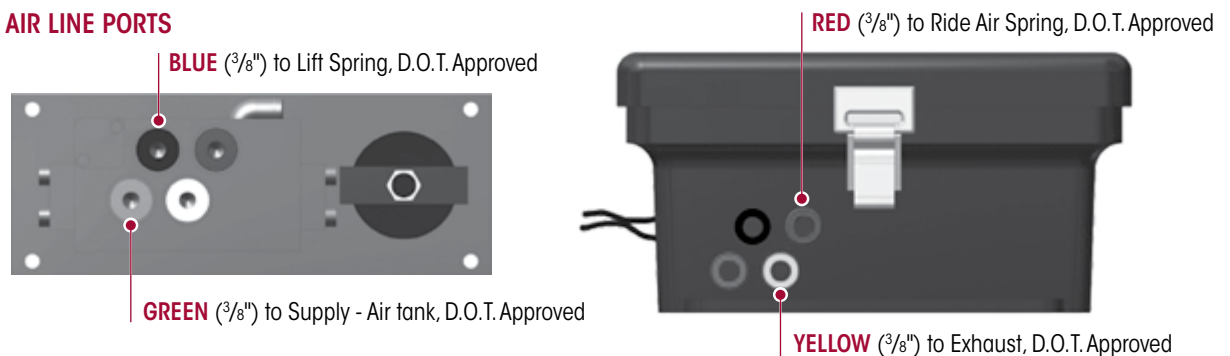
INSTALLATION INSTRUCTIONS

It is important to read and understand this entire installation instruction and all recommended safety precautions prior to performing any installation, service or maintenance of the product. Ensure the air control components match the desired lift axle application.

1. Refer to the Plumbing and Wiring Diagram in Section 6 of this publication.
2. Mount the air control valve inside or outside the cab as required.
3. Route the air lines required for all kits, see Figures 5-1 and 6-1 (Air and Electrical Diagram):
 - a. Route an air line from the **GREEN PORT** to the lift axle supply air tank. Install the pressure protection valve (R-009689), and in-line air filter (R-013282) both listed in Figure 4-1 oriented with the arrow pointing in the direction of flow. Install the in-line air filter (R-013282) oriented as shown in Figure 5-2.
 - b. Route an air line from the **RED PORT** to the lift axle ride springs. Install the Quick-Exhaust valve (R-004348-1), listed in Figure 6-3, acting as a tee to both ride springs. Mounting the Quick-Exhaust valve close to the tanks will improve the axle's lift time.
 - c. Route an air line from the **BLUE PORT** to the lift axle lift springs using a T-fitting as necessary.
 - d. Route a small length of tubing from the **YELLOW PORT** to a protected area to reduce the chance of debris entering the valve. For Inside-Mounted controls, routing the exhaust hose outside of the cab will reduce noise.

FIGURE 5-1

AIR LINE PORTS



4. If equipped with a two-wire solenoid valve, connect one (1) lead to a good vehicle ground and the other to a good reverse signal such as the reverse light wiring. **DO NOT** connect solenoid to reverse signal if equipped with Electric Override Switch (R-009791), see Figure 6-4. Move on to the next step.
5. If equipped with the Electric Override Switch (R-009791), refer to the Electric Override Switch Diagram in Section 6 and make the following connections, see Figure 6-4.

NOTE

If equipped with a non-steerable lift axle or an air control kit that defaults to lift such as HAC-MCA or HAC-MSO, special wiring instructions are included.

- a. Connect **A** red wire from Relay Terminal 86 to a good reverse signal. For non-steerable lift axle applications, do not connect. Cap off this wire to avoid grounding.
- b. Connect **B** white wire from Relay Terminal 30 to the open lift axle control solenoid wire.
- c. Connect **C** red wire from Relay Terminal 87a to the toggle switch and another from the open toggle switch terminal to a +12v DC power source. An Ignition "Accessory On" power source is recommended.
- d. Connect **D** black wire from Relay Terminal 85 to a good vehicle ground.
- e. Connect **E** red wire from Relay Terminal 87 to a +12v DC power source. An Ignition "Accessory On" power source is recommended. For non-steerable lift axle applications do not connect. Cap off this wire to avoid grounding. For default to lift air control kits including HAC-MCA and HAC-MSO do not connect. Cap off this wire to avoid grounding.

6. **HAC-LSI / LCO / LSO specific instruction:**
 - a. Find a position inside the frame or body to mount the Reverse Lift & Lock valve (R-009790). Preferably near the lift axle.
 - b. Add a Tee in the Supply line and route an air line to the Reverse Lift & Lock **Port 1**.
 - c. Add a Tee in the Lift line and route a line to the Reverse Lift & Lock **Port 3**.
 - d. Route an air line from the Reverse Lift & Lock **Port 2** to the Lock Straight chambers mounted on the axle using a Tee as necessary.
7. **HAC-RSI / RCO / RSO specific instruction:**
 - a. Find a position inside the frame or body to mount the Reverse Down & Lock valve (R-009790-1). Preferably near the lift axle.
 - b. Add a Tee in the Supply line and route an air line to the Reverse Down & Lock **Port 1**.
 - c. Route an air line from the Reverse Down & Lock **Port 2** to the Lock Straight chambers mounted on the axle using a Tee as necessary.
 - d. Follow the diagram on Electric Override Switch, see Figure 6-4.
8. **HAC-ASI / ACO / ASO specific instruction:**
 - a. Find a position inside the frame or body to mount the Reverse Caster valve (R-010028). Preferably near the lift axle.
 - b. Add a Tee in the Supply Line and route an air line to the Reverse Caster valve **Port 1**.
 - c. Add a Tee in the Lift Line and route a line to the Reverse Caster **end port** 90-degree fitting.
 - d. Route an air line from the Reverse Caster **Port 2** to the Reverse Caster chambers mounted on the suspension hanger using a Tee as necessary.
 - e. Follow the diagram on Electric Override Switch, see Figure 6-4.

INSTALLATION TIPS

CAUTION

USE A FILTER RATED TO AT LEAST 40 MICRONS ON THE INCOMING (GREEN) SUPPLY AIR LINE TO THE AIR CONTROL VALVE. ANYTHING LESS COULD ALLOW DEBRIS AND PARTICULATES THROUGH, WHICH COULD BE DETRIMENTAL TO THE AIR CONTROL VALVE COMPONENTS.

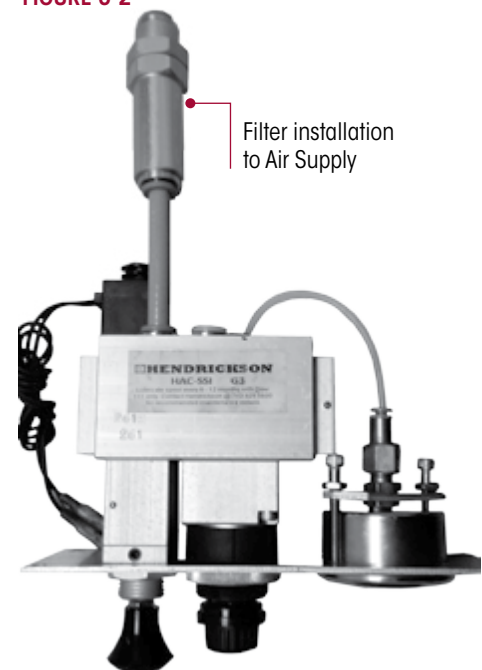
- Use only air brake tubes that conform to S.A.E. J844 and ensure all tubes are free from kinks.
- Ensure that the minimum bend radii are achieved on all tubes prior to assembly.

RECOMMENDED MINIMUM BEND RADII:

- ¼" Tube – 1.0 inch
- ½" Tube – 2.0 inches
- ¾" Tube – 1.5 inches
- 5/8" Tube – 2.5 inches

- Use only dedicated tube cutters when preparing tube ends for insertion into push-in fittings.
- Ensure tube ends are square, free from all damage, and clean.
- Ensure tube is fully inserted into fittings (tube ends are pushed past both the grip ring and the sealing O-ring).
- Ensure fitted panels have enough free length of tube to ensure the tube in the fittings is not under any tension.
- Crimp wires for all electrical connections into the butt connectors provided using an appropriate crimp tool.
- Ensure there is sufficient free electrical cable to prevent wires and connections from being under tension.

FIGURE 5-2

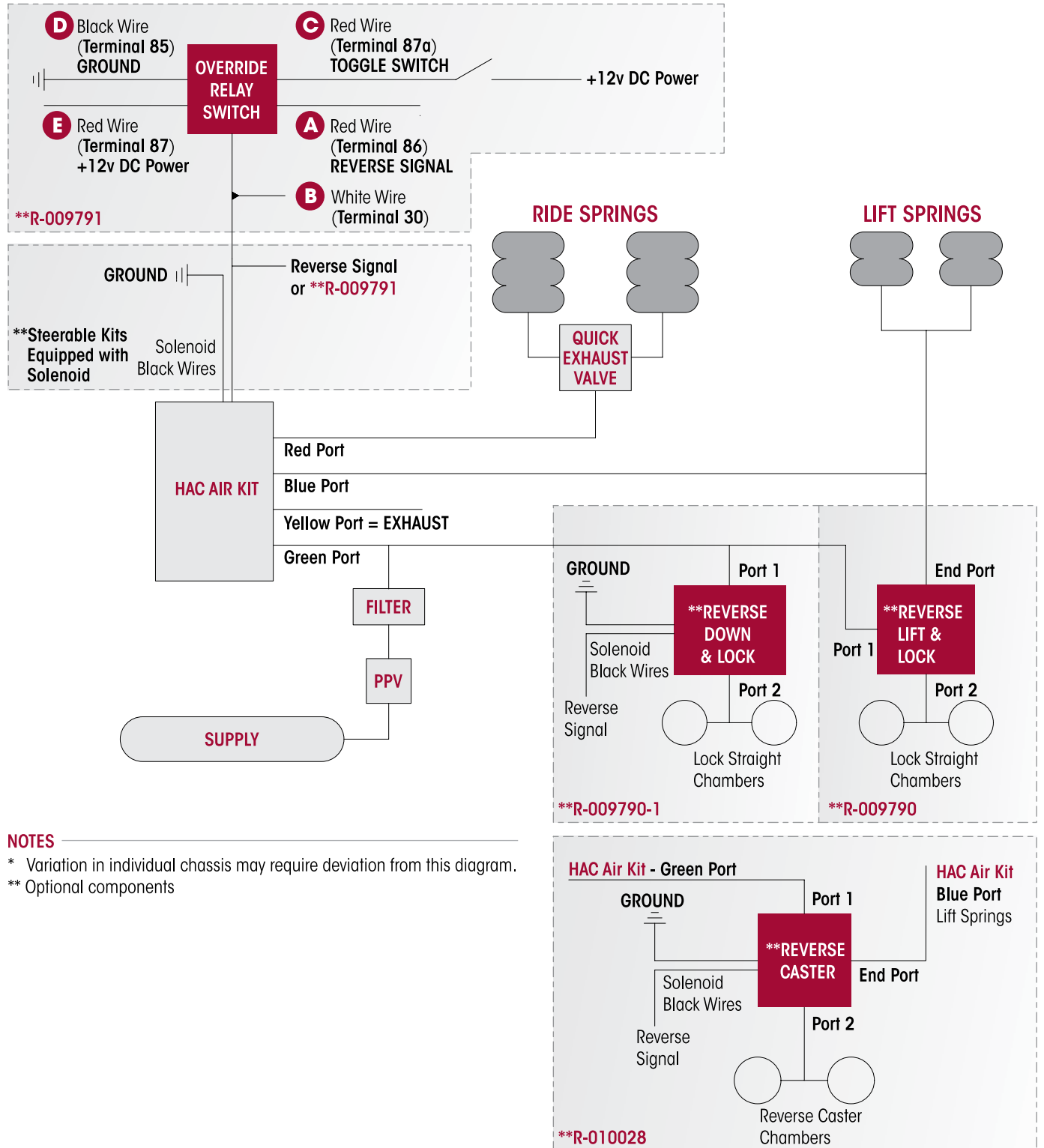


SECTION 6 Plumbing & Wiring Diagram

FIGURE 6-1

***AIR and ELECTRICAL DIAGRAM**

****Reverse Down & Lock • **Reverse Lift & Lock • **Reverse Caster**



NOTES

- * Variation in individual chassis may require deviation from this diagram.
- ** Optional components

FIGURE 6-2
REVERSE VALVES

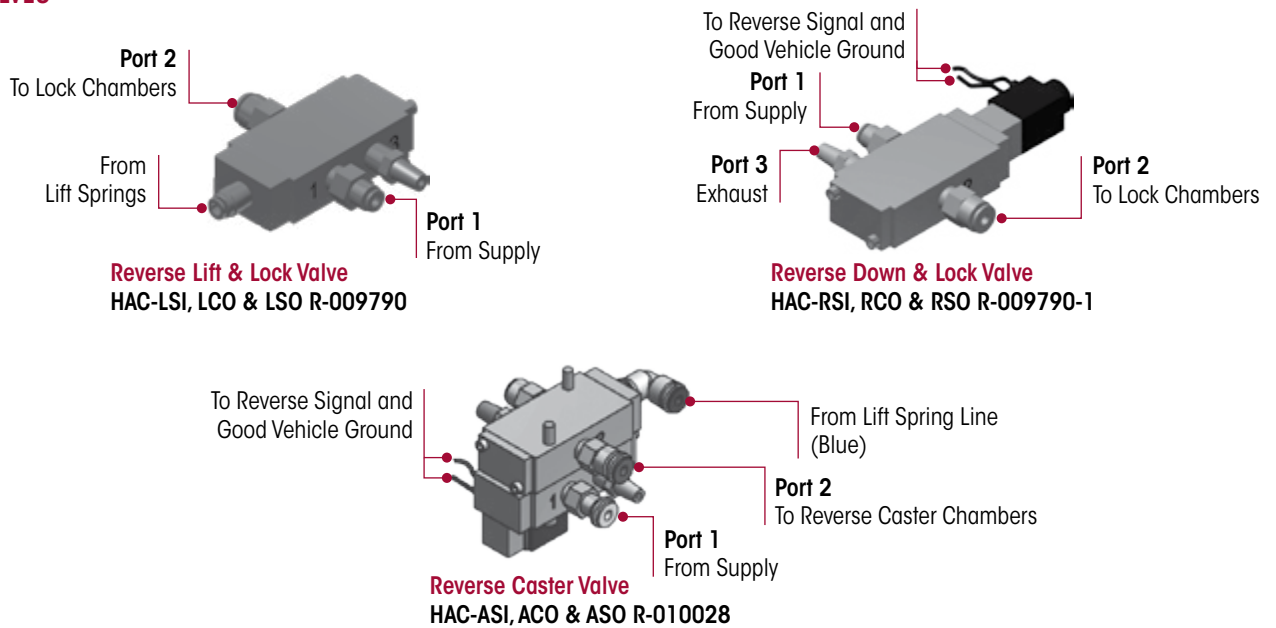


FIGURE 6-3
PLUMBING DIAGRAM

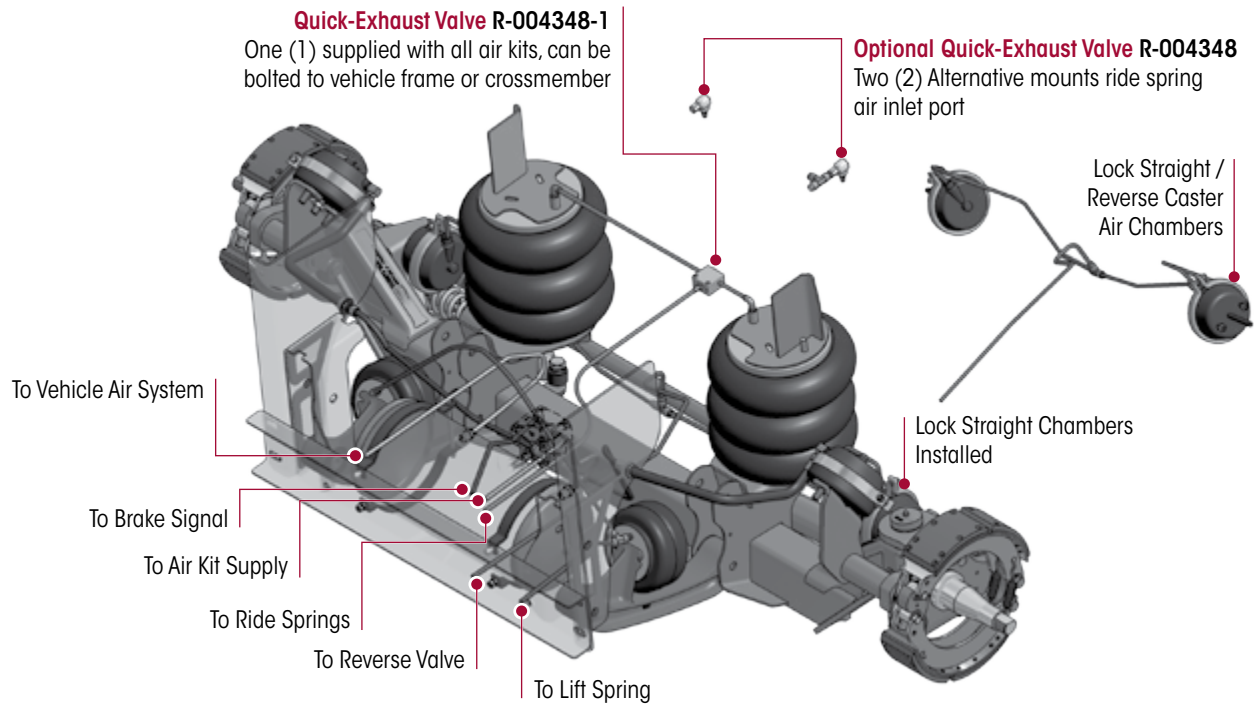
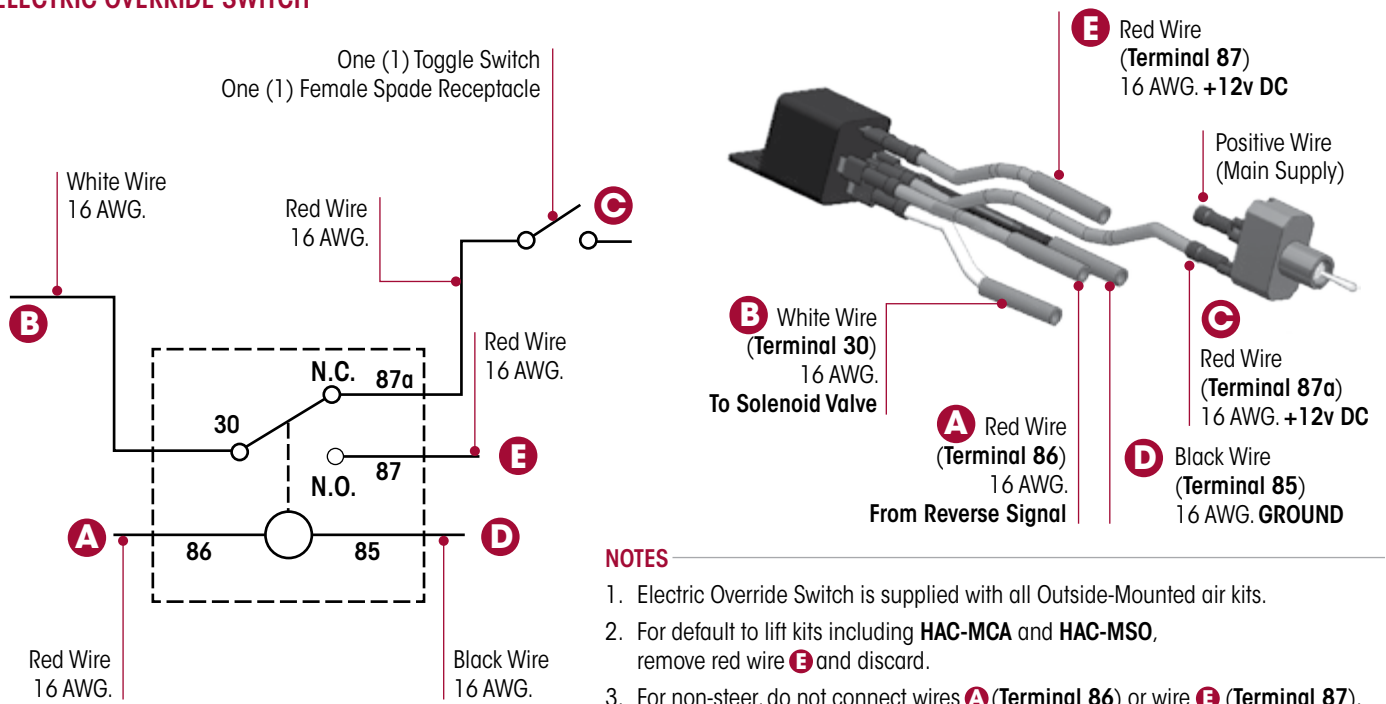


FIGURE 6-4
ELECTRIC OVERRIDE SWITCH



NOTES

1. Electric Override Switch is supplied with all Outside-Mounted air kits.
2. For default to lift kits including **HAC-MCA** and **HAC-MSO**, remove red wire **E** and discard.
3. For non-steer, do not connect wires **A** (Terminal 86) or wire **E** (Terminal 87). This disables lift in reverse function but maintains Lift Override function.

SECTION 7

Suspension Operation

RAISING YOUR LIFT AXLE

1. If vehicle is already running, please proceed to Step 6.
2. Set vehicle parking brakes.
3. Turn your vehicle ignition to on position.
4. Press start switch and release when engine is started.
5. Allow the vehicle to idle until the vehicle air system pressure has reached the compressor cut-out pressure (usually 120 psi).
6. **If controls are Inside-Mounted** – Pull the lift / lower control knob out to immediately lift the axle.
7. **If controls are Outside-Mounted** – Ensure the vehicle is stopped and parking brake is set. Exit the vehicle, go to air control enclosure and open it. Pull the lift / lower control knob out to immediately lift the axle.
 - **Equipped with Electric Override Switch Part No. R-009791** – Turning the switch to the **ON** position will override the push/pull knob and raise the axle. Turning the switch off will immediately redeploy the axle. Likewise terminating power to the switch, such as turning the vehicle off will immediately redeploy the axle.
8. Visually confirm the axle is lifting.

NOTE Vehicle system air pressure may drop during suspension lifting process.

9. Lift axle should be completely lifted when the vehicle's air system pressure returns to the air compressor cut-out point (usually 120 psi).
10. Hendrickson recommends raising the lift axle when not in use and when off-road.

LOWERING YOUR LIFT AXLE

1. If the vehicle is already running, please proceed to Step 6.
2. Set the vehicle parking brake.
3. Turn your vehicle ignition to the **ON** position.
4. Press the start switch and release when engine has started.
5. Allow the vehicle to idle until the vehicle air system pressure has reached the compressor cut-out (usually 120 psi).

CAUTION

DO NOT LOWER LIFT AXLE WHILE THE VEHICLE IS MOVING IN REVERSE OR TRAVELING AT MORE THAN 15 MPH. FAILURE TO DO SO CAN CAUSE COMPONENT DAMAGE.

6. **If the controls are Inside-Mounted** — Push the lift / lower control knob in to immediately lower the axle.
7. **If the controls are Outside-Mounted** — Ensure the vehicle is stopped and the parking brake is set. Exit the vehicle, go to air control enclosure and open it. Push the lift / lower control knob in to immediately lower the axle.
 - **Equipped with an Electric Override Switch Part No. R-009791** — If the axle fails to deploy toggle the override switch in the cab to the **OFF** position.
8. Using the regulator, adjust air pressure on the gauge to the appropriate air pressure for vehicle load conditions. See air pressure load charts in the applicable Hendrickson Auxiliary Lift Axle Owner's Manual Literature No. OM-H754 (Steerable) or Literature No. OM-H757 (Non-Steerable).

NOTE Air system pressure may drop during the suspension lowering process.

9. Lift Axle should be completely lowered and supporting the pre-determined load when system air compressor cut-out point is reached (usually at 120 psi).

SECTION 8 Preventive Maintenance

HENDRICKSON RECOMMENDED MAINTENANCE INTERVALS

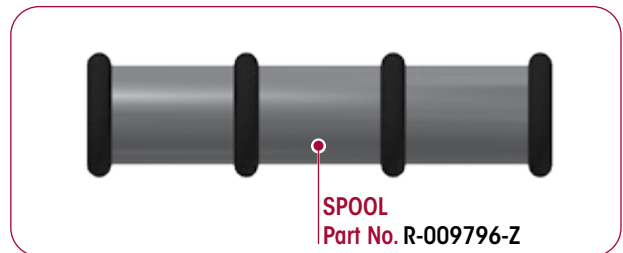
- Air Control Filter System** – Every six months remove the filter (Part No. R-013462) from the Air Control Filter System, see Figure 8-1. Visually inspect the filter for contaminants and replace as necessary to help ensure efficient operation. An indication that the filter may need replacement is when a notable reduction in the axle retract or deployment time has occurred.

FIGURE 8-1



- Spool** – Lubricate as needed. If the valve is leaking air or failing to change state from lifted to lowered the spool (Part No. R-009796-Z) may need to be lubricated or replaced. Refer to the Troubleshooting Guide in this publication.

FIGURE 8-2



SECTION 9 Tech Tips

SUBJECT	TECH TIPS
1. HAC-UCO & HAC-USO	Air kit knob must be in and lift axle down before activating override switch.
2. Gauge Pressure	<ol style="list-style-type: none"> The circuit schematic indicates that the gauge is reading the regulator's output pressure. When the valve is in "lift mode", the regulator output port is still under pressure but is blocked at the main valve. This way, the operator always knows what the ride spring pressure is going to be when the control shifts from "lift mode" to "ride mode". When the main valve is shifted to "ride mode", the pressure indicated on the gauge is exactly what is in the ride springs. Otherwise, what the gauge indicates is what will be in the ride springs once they have been lowered. The gauge is a constant indicator of the pressure that will be going to the ride springs.



SECTION 10

Frequently Asked Questions

NOTE All brake plumbing installations must adhere to FMVSS-121 regulations. Modification to a vehicle's pneumatic system may alter it's compliance to FMVSS-121 regulations.

QUESTION	RESPONSE
1 Where do I install my Hendrickson air kit control panel?	The Hendrickson air kit product line is available for Inside- and Outside-Mounting. Your particular application will be dictated by regulations in your state(s) of operation.
2 My axle goes down after the truck is shut down and it raises the entire chassis. Can I make the axle stay in the up position?	<p>This symptom is an indication that the Electric Override Switch maybe in the ON position and the outside the cab lift axle control knob is pushed in to the lower position. Hendrickson recommends</p> <ul style="list-style-type: none"> ■ If controls are Inside-Mounted – Pull the lift / lower control knob out to immediately lift the axle. ■ If controls are Outside-Mounted – Ensure the vehicle is stopped and parking brake is set. Exit the vehicle, go to air control enclosure and open it. Pull the lift / lower control knob out to immediately lift the axle. <p>There are two (2) options to have the lift axle stay in the UP position without having to exit the vehicle to operate an Outside-Mounted control.</p> <p>Option 1: With your current air kit installed, rewire the +12v DC power source from the switch. Connect it to the battery instead of accessory ON power. Amp draw on battery is 0.4a or 4.8 watts.</p> <p>Option 2: Install the HAC-MCA air control, which is designed to default to the lifted position with the power off. Changing to the HAC-MCA will keep the axle up when the vehicle is shut down</p>
3 Can I plumb my air kit in-line with my ride height control valve?	Complete vehicle assessment should be conducted considering primary suspension load share and vehicle handling performance. Specific instances can be reviewed by Hendrickson Technical Service Department.
4 At what pressure should the regulator be set?	Typically 70-120 psi. – All new lift axle and air control installations should be verified at a certified scale to determine correct air pressures vehicle loading. See air pressure load charts in the applicable Hendrickson Auxiliary Lift Axle Owner's Manual Literature No. OM-H754 (Steerable) or Literature No. OM-H757 (Non-steerable). Improper vehicle loading can cause handling irregularities and component damage.
5 How do I identify my air kit?	For Inside-Mounted air kits, the identification tag should be located on the top of the control module. For Outside-Mounted air kits, the identification tag should be located on the inside of the door panel.
6 Why do steerable suspensions require auto lift in reverse?	Due to the positive caster angle built into Hendrickson steerable lift axles they are designed to track with the vehicle in forward motion. Moving in reverse the wheels will lock sideways and scrub the tires imparting high stress on the axle and leading to potential damage.
7 How does the reverse locking option engage?	The reverse locking option requires both an axle with the lock straight optional components installed and an air control specified to control the lock straight. The relay in the air control kit is wired to sense the activation of the reverse lights when the vehicle transitions to reverse gear. The relay will energize the lift axle control solenoid to switch the valve to lift mode.
9 Why does my pressure gauge show ride pressure when axle is raised?	The gauge will show a constant value for pressure dialed into the regulator. This makes technicians and operators aware of both ride pressure and stored pressure, which can cause severe personal injury and component damage. Refer to the Tech Tips Section in this publication for more information.
10 How do I determine the functionality of each kit component?	<ul style="list-style-type: none"> ■ Green fitting to supply ■ Actuator knob pulled out for lift axle raise ■ Actuator knob pushed in for lift axle lower ■ Blue fitting to lift springs ■ Red fitting to ride springs ■ Yellow exhaust for lift springs ■ Black fitting for applicable lock components



SECTION 11 Troubleshooting Guide

HAC AIR KITS

TROUBLESHOOTING GUIDE

PROBLEM	POSSIBLE CAUSE	CORRECTION
Automatic lift does not function or manual lift does not function with push / pull valve on air kit control panel	Lack of air kit lubrication	Service air kit by removing and replacing the spool with Part No. R-009796-Z or adding lubrication to existing spool (Dow Ill only) with Part No. R-010880.
	Air control system not properly installed	Connect black wire to vehicle ground and black wire to backup light power wire. Confirm +12v DC signal when reverse lights are on.
	Solenoid on air kit control panel is not being energized	
	Kinked, pinched, or broken air line between air kit control panel and lift springs	Replace pinched, kinked or broken air lines.
	Kinked, pinched, or broken air line between air kit control panel and supply tank	
	Supply air pressure insufficient to operate lift mechanism	Verify that you are receiving 100 psi minimum at the lift axle control panel. Use calibrated gauge at supply line inlet.
	Non-functioning Quick-Exhaust valves between ride springs	A non-functioning Quick-Exhaust valve can keep air trapped in ride springs. Engaged ride springs will overpower the lift springs to keep axle down. Replace non-functioning Quick-Exhaust valve.
	Exhaust port on back of air kit control panel plugged	Remove obstruction to exhaust port on back of air control panel.
	Air kit control panel not properly plumbed	Confirm that the air kit control panel is plumbed per the appropriate diagram in this book.
Non-functioning air kit control panel	Call Hendrickson Warranty Department.	
Does not lower or does not inflate ride springs with panel knob pushed in	Lack of air kit lubrication due to contamination	Service air kit by removing and replacing the spool with Part No. R-009796-Z or adding lubrication to existing spool (Dow Ill only) with Part No. R-010880.
	Regulator turned down too low	Increase air pressure at regulator until desired load is carried at wheels.
	Truck in reverse gear	Place transmission in forward gear or neutral.
	Solenoid valve on back of air kit control panel energized	Place transmission in forward gear or neutral. If problem persists verify the source of the solenoid power is a reverse signal and not some alternate source.
	Kinked, pinched, or broken air line between air kit control panel and ride springs	Replace pinched, kinked or broken air lines.
	Kinked, pinched, or broken air line between air kit control panel and supply tank	
	Supply air pressure insufficient to operate lower mechanism	Verify that you are receiving 100 psi minimum at the lift axle control panel. Use calibrated gauge at supply line inlet.
	Exhaust port on back of air kit control panel plugged	Remove obstruction to exhaust port on back of air control panel.
	Air kit control panel not properly plumbed	Confirm that the air kit control panel is plumbed per the appropriate diagram in this book.
Non-functioning air kit control panel	Call Hendrickson Warranty Department.	



HAC AIR KITS

TROUBLESHOOTING GUIDE

PROBLEM	POSSIBLE CAUSE	CORRECTION
Slow lift or lower times	Lack of air kit lubrication due to contamination	Service air kit by removing and replacing the spool with Part No. R-009796-Z or adding lubrication to existing spool (Dow III only) with Part No. R-010880.
	Insufficient air flow or volume being delivered to air kit control panel	Increase incoming air line size or increase air reservoir capacity.
	Insufficient air flow or volume being delivered to the air springs	Increase air line size from 3/8" to 1/2" going to air spring air lines.
	Insufficient ride spring exhaust through Quick-Exhaust valve.	Verify Quick-Exhaust valve is operating correctly. Move Quick-Exhaust valve closer to the ride springs. If problem persists install one (1) Quick-Exhaust valve per air spring to increase exhaust flow.
Quick-Exhaust valve inoperable	Clogged or plugged quick-exhaust valves	Remove obstruction or replace quick-exhaust valve, Part No. R-004348-1.
Suspension does not carry rated load	Insufficient air pressure in ride springs	Increase pressure in the ride springs by increasing the regulator setting. Check pressure in the ride springs at air spring inlet.
	Supply air pressure insufficient to carry rated load	Verify that you are receiving 100 psi minimum at the lift axle control panel. Use calibrated gauge at supply line inlet.
	Kinked, pinched or broken hose between air kit control panel and ride springs	Replace pinched, kinked or broken air lines.
	Kinked, pinched or broken hose between air kit control panel and supply tank	
	Non-functioning air kit control panel	Call Hendrickson Warranty Department.
Incorrect lift axle ride height	Call Hendrickson Technical Service Department.	
Lift axle control is leaking air	Leaking from little red button on the solenoid	The red button is a small on / off valve. Using a small flat head screw driver turn the red valve from the open position to closed. O / I markings molded into the solenoid indicate the positions.
	Leaking from an air line fitting	Remove the air line and reinstall confirming the line is fully seated. If problem persists, cut off a short section of line per the direction on line cutting and reinstall to confirm a clean cut that will interface properly with the fitting.
	Leaking from the exhaust port	The spool inside the valve may be stuck in the incorrect position or shifted part way between positions due to lack of lubrication or swollen O-rings. The spool O-rings may also be damaged. Service the spool with Service Kit R-009796-Z.
	Leaking from the regulator	Faulty regulator. Return kit to Hendrickson for service replacement.

www.hendrickson-intl.com



Specialty Products - Auxiliary Axle Systems
 277 North High Street
 Hebron, OH 43025-8008 USA
 1.800.660.2829 (Toll-free U.S. and Canada)
 1.740.929.5600 (Outside U.S. and Canada)
 Fax 1.740.929.5601

Hendrickson Canada
 250 Chrysler Drive, Unit #3
 Brampton, ON L6S 6B6 Canada
 905.789.1030
 Fax 905.789.1033