

- Variety of solutions to minimize trailer walk and/or trailer drop during loading and unloading



Dump valves minimize trailer walk

When maintaining deck height is not critical but controlling trailer walk is still important, Hendrickson offers automatic and manual dump valves. These pneumatic controls help minimize trailer walk by exhausting air bags, thereby lowering the trailer onto the internal air spring bumpers.

Ride height lock mechanism minimizes trailer walk and trailer drop

The SURELOK® mechanism features locking legs that provide maximum engagement with the suspension beams. A robust return spring enhances durability and a metal "flange" at the bottom rear of each SURELOK leg ensures proper positioning. SURELOK is designed for the customer who must maintain ride height during loading and unloading. Since the trailer is rigidly supported, dock-walk is also minimized. Support legs are automatically engaged when the trailer's parking brakes are set. When the parking brake is released, SURELOK's support legs automatically retract. No driver interaction is required.



To learn more about SURELOK, call 866.743.3247 or visit www.hendrickson-intl.com

Hendrickson offers a variety of SURELOK® solutions tailored to meet your specific needs.

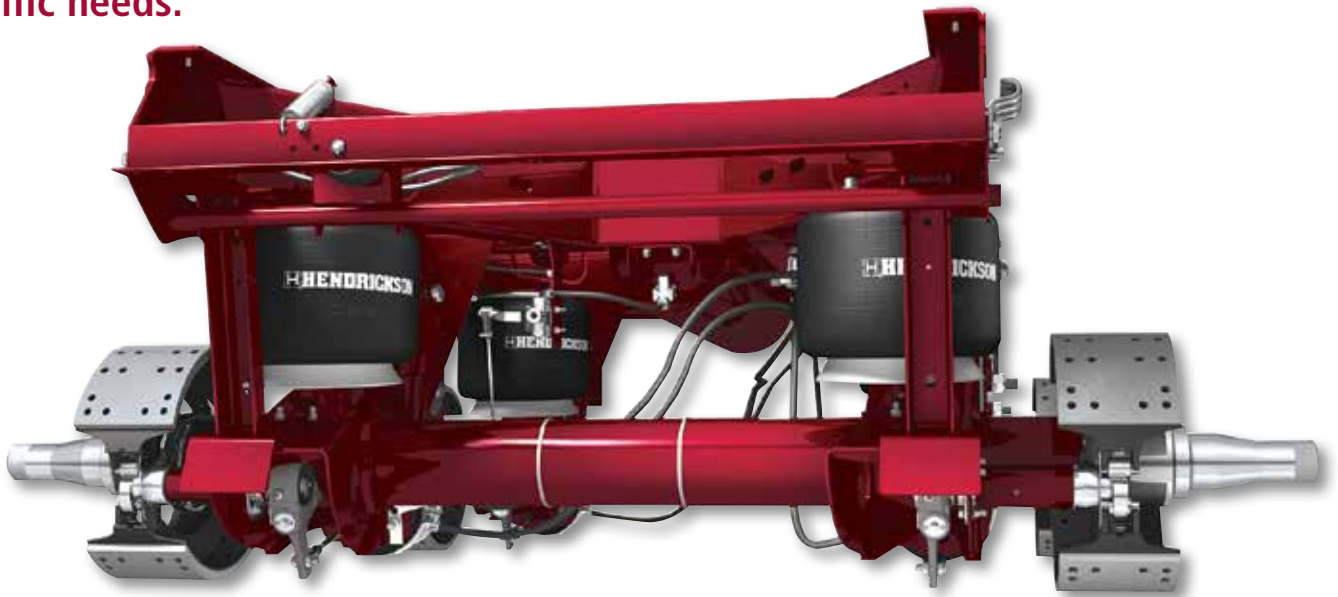

Loading Dock Solutions

- 1. Trailer Drop and Walk** — SURELOK® ride height lock mechanism is recommended for maintaining current ride height when the operator cannot afford to allow the trailer to drop three inches (normal up travel) for efficient trailer dock operations. A second benefit of SURELOK is minimizing trailer walk by limiting vertical and horizontal movement.
- 2. Trailer Walk** — When maintaining ride height is not a concern but trailer walk is, Hendrickson recommends its line up of dump valves.



For additional information refer to the following Hendrickson publications:

See *SURELOK Operator's Manual* - **L498**

See *Loading dock approach procedure for trailers equipped with an automatic air suspension dump valve* - **B109**

See *DST® - Dock Stabilizing Technology™* - **L781**



Actual product performance may vary depending upon vehicle configuration, operation, service and other factors.

All applications must comply with applicable Hendrickson specifications and must be approved by the respective vehicle manufacturer with the vehicle in its original, as-built configuration. Contact Hendrickson for additional details regarding specifications, applications, capacities, and operation, service and maintenance instructions.

Call Hendrickson at **330.489.0045** or **866.RIDEAIR (743.3247)** for additional information.



www.hendrickson-intl.com

TRAILER COMMERCIAL VEHICLE SYSTEMS

2070 Industrial Place SE
Canton, OH 44707-2641 USA
866.RIDEAIR (743.3247)
330.489.0045 • Fax 800.696.4416

Hendrickson Canada

250 Chrysler Drive, Unit #3
Brampton, ON Canada L6S 6B6
800.668.5360
905.789.1030 • Fax 905.789.1033

Hendrickson Mexicana

Circuito El Marqués Sur #29
Parque Industrial El Marqués
Pob. El Colorado, Municipio El Marqués,
Querétaro, México C.P. 76246
+52 (442) 296.3600 • Fax +52 (442) 296.3601