

- MAAximise payload
- MAAximise performance
- MAAximise durability

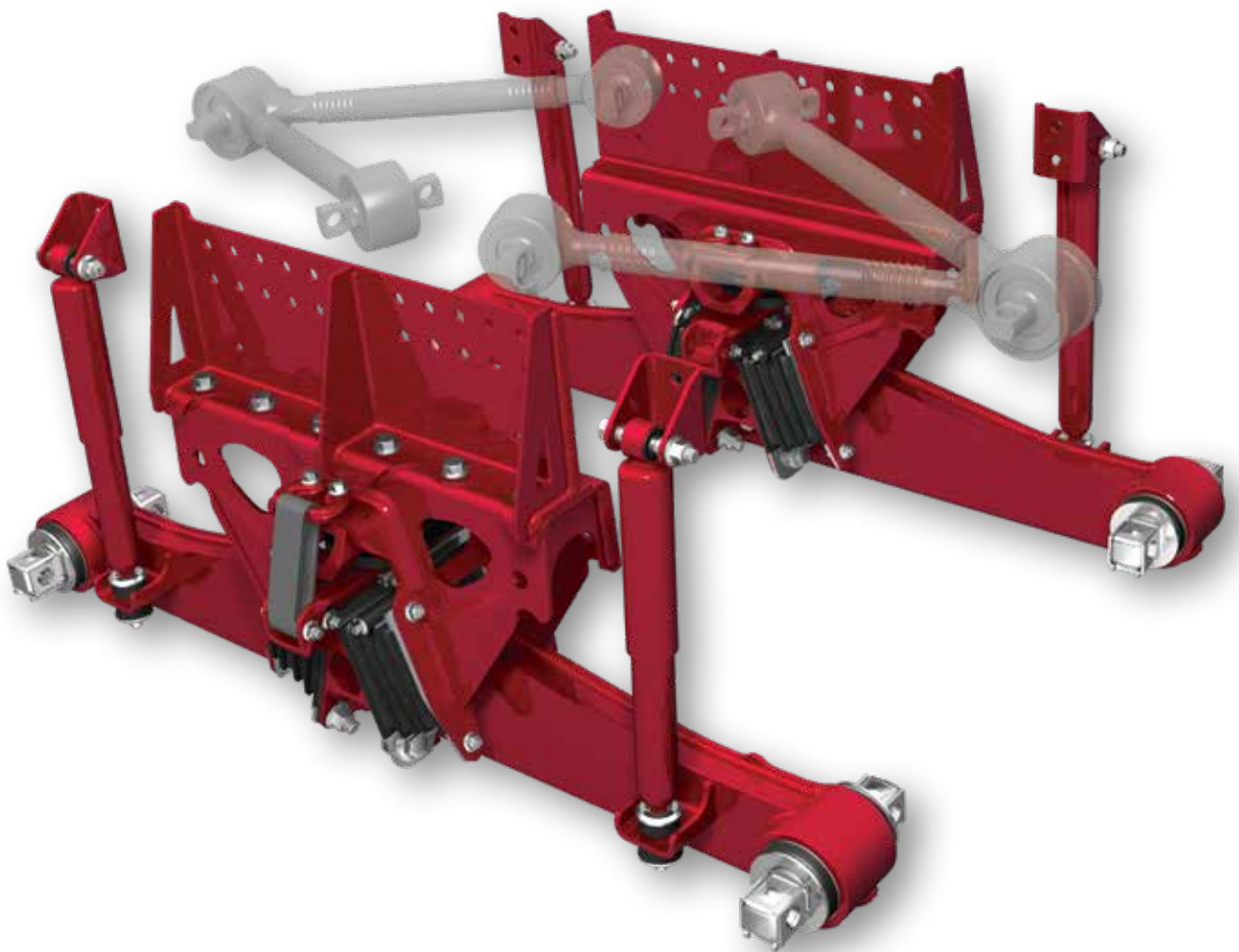

To learn more about HAULMAAX EX,  
call Hendrickson or visit  
[www.eu.hendrickson-intl.com](http://www.eu.hendrickson-intl.com) for  
additional information.



### MAAXimise Payload and Durability

Suspension geometry is optimised to provide better site rating, increased capacity ranges and improved durability. Utilising industry leading validation techniques, high strength materials and advanced manufacturing methods, HAULMAAX<sup>®</sup> EX meets the increasing rigorous application demands by delivering the reliability and quality you've come to expect from Hendrickson, the leader in suspension technology.

#### Progressive Load Spring

- Increases stiffness as the load increases, providing a unique balance of empty ride quality and laden stability
- Provides long service life and easy replacement for reduced down time
- Eliminates shim adjustments for lower maintenance

#### Saddle and Frame Bracket

- Lightweight, modular design simplifies installation

#### Bar Pin End Connection

- Rugged axle connection extends bushing life and allows easy axle alignment and serviceability

#### Premium Rubber Bolster Springs

- The unique design works with the Progressive Load Spring to deliver exceptional empty ride quality and laden stability
- Optimised angle allows bolster springs to carry the majority of the payload and still react to braking and accelerating forces with minimal displacement

#### Dual Strap Kit

- Provides additional bolster spring protection
- Required on vehicles equipped with outriggers
- Available as production or aftermarket options

#### Equalizing Beam

- Formed and robotically-welded beam provides a narrow profile for weight savings
- Distributes load equally between both axles for improved manoeuvrability, stability and handling
- Lowers the center of gravity to increase stability
- Narrow, offset beam allows for better packaging and increased tire clearance
- Center bushing eliminated for reduced maintenance

#### Optional TRAAX RODS and Longitudinal Rods

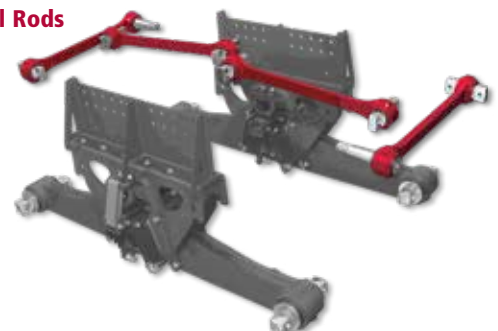

## MAAXimise Performance

HAULMAAX® EX features a unique spring design that balances empty-ride quality and laden stability. Angled bolster springs and a unique progressive load spring provide exceptional stability for demanding applications such as refuse, concrete mixers and tippers.

### How it Works:



**Unladen**

- In the empty condition, the suspension rides primarily on the angled rubber bolster springs which help absorb road inputs and fore / aft shock for outstanding ride quality.



**Laden**

- As payload is added and the vehicle center of gravity increases, the progressive load spring compresses and increases in stiffness to provide additional stability without abrupt changes in ride.



**Fully Laden**

- Once fully engaged, the progressive load spring is supported by an integrated jounce stop; protecting the rubber components from over-compression.

## MAAXimise Uptime

### Help reduce life cycle costs and increase the uptime of your vehicle:

- Superior ride reduces road shock and vibration to the vehicle for longer service life and fewer repairs to the cab, chassis and body equipment
- No lubrication requirements
- Fewer bushings to maintain — center bushing eliminated
- Rubber springs provide long service life and easy replacement
- Bar pin end bushings extend service life and provide alignment capability for longer tire life
- Hendrickson torque rod bushings provide longer service life than conventional bushings
- Hendrickson parts and service available at thousands of locations worldwide
- Comprehensive technical support and training

## MAAXimise Mobility and Traction

HAULMAAX EX provides the versatility for demanding job-site conditions. When laden, HAULMAAX EX delivers up to 430mm\* of diagonal wheel articulation to keep load on all drive wheels. Unladen articulation varies with vehicle configuration and empty body weight. In addition, unlike other walking-beam suspensions, the innovative HAULMAAX EX design eliminates fixed center bushing pivot points to reduce wheel hop.

\* Suspension articulation may exceed vehicle's capability and may be limited by vehicle manufacturer; vehicle manufacturer installed axle stops may restrict suspension's articulation.



# HAULMAAX® EX Specifications

Model	HMX EX 400	HMX EX 460	HMX EX 520
Installed Weight <sup>1</sup> (kg)	388	392	434.5 <sup>8</sup>
Suspension Rating (tons)	18	21	23.5
Diagonal Articulation <sup>4</sup> (mm)	432	432	432
Lift Axles	Approved	Approved	Approved
Ride Heights <sup>5</sup> (mm)	241 – 336.5	241 – 336.5	241 – 336.5
Axle Spacing <sup>6</sup> (mm)	1,320 and 1,370	1,320 – 1,800	1,320, 1,370, 1,500

Hendrickson approves the use of HAULMAAX® EX in the following vocational truck applications: tipper, concrete mixer, refuse, logging, crane / boom, and platform.

1. Installed weight includes complete suspension, torque rods, axle brackets and frame brackets; add 14 kg for shock absorbers.
2. Contact Hendrickson for applications that may exceed GVW approval ratings.
3. Job-site travel rating — operators using vehicles equipped with liftable pusher or tag axles must not exceed published ratings. Job-site ratings are limited to no more than five percent of vehicle operation at speeds not to exceed five mph. Liftable pusher or tag axles should only be raised (or unloaded) to improve vehicle maneuverability in job-site applications or when vehicle is empty. Job-site travel ratings are consistent with published axle manufacturer's limitations. Axle and suspension job-site travel specifications must not be exceeded.
4. Suspension articulation may exceed vehicle's capability and may be limited by vehicle manufacturer; vehicle manufacturer installed axle stops may restrict suspension's articulation.
5. HAULMAAX EX ride height measurements are taken from the centerline of the axle to the bottom of the truck frame.
6. Contact Hendrickson for availability of beam lengths.
7. Shock absorbers are required in tractor and logging applications. Ride and traction may be improved in other applications with shock absorbers. Ride performance can be subjective and may be dependent on many factors beyond the suspension design such as cab suspension, road conditions, body/auxiliary equipment, frame specifications, etc. Contact Hendrickson or your truck manufacturer /dealer for further information.
8. 23.5t installed weight includes complete suspension, double rebound straps, longitudinal torque rods, Hendrickson TRAAX ROD™ transverse torque rods, axle brackets and frame brackets; add 14 kg for shock absorbers.



*Optional TRAAX RODS and Longitudinal Rods with and without dampers for specific applications or markets*

Technical literature available at [www.hendrickson-intl.com](http://www.hendrickson-intl.com) or contact Hendrickson at 855.743.3733.

**Hendrickson Genuine Parts** are the same quality components installed in Hendrickson original equipment suspensions — consisting of the same design, construction, performance and durability. There's only one way to maintain and protect your suspension's original performance. Ask for the name that is synonymous with the finest manufactured suspensions in the world.

Extended Warranty options available at [www.hendrickson-intl.com](http://www.hendrickson-intl.com)

*Actual product performance may vary depending upon vehicle configuration, operation, service and other factors.*

*All applications must comply with applicable Hendrickson specifications and must be approved by the respective vehicle manufacturer with the vehicle in its original, as-built configuration. Contact Hendrickson for additional details regarding specifications, applications, capacities, and operation, service and maintenance instructions.*

Call Hendrickson or visit our global websites for additional information.



840 Sought Frontage Road  
Woodridge, IL 60517-4900 USA  
+1.630.874.9700

**Hendrickson Commercial Vehicle Systems Europe**  
Hendrickson Austria GmbH  
Gussstahlwerkstraße 21  
A-8750 Judenburg, Austria  
+43 3572 44011 400  
[eu.hendrickson-intl.com](http://eu.hendrickson-intl.com)

**Hendrickson Truck Commercial Vehicle Systems**  
800 South Frontage Road  
Woodridge, IL 60517-4904 USA  
+1.855.743.3733  
+1.630.910.2800  
[www.hendrickson-intl.com](http://www.hendrickson-intl.com)

**Hendrickson Trailer Commercial Vehicle Systems**  
2070 Industrial Place SE  
Canton, OH 44707-2641 USA  
+1.866.743.3247  
+1.330.489.0045  
[www.hendrickson-intl.com](http://www.hendrickson-intl.com)

**Hendrickson Commercial Vehicle Systems Oceania**  
32-44 Letcon Drive  
Dandenong South, Victoria,  
3175 Australia  
+61 3 8792 3600  
[aus.hendrickson-intl.com](http://aus.hendrickson-intl.com)

**Hendrickson Commercial Vehicle Systems China**  
No. 1668  
North Section of Chunbo Road  
East New Dist of Jinan High-Tech  
Industrial Development Zone,  
Jinan City, Shandong Province,  
China, 250104  
+86 531 8880 9055  
[china.hendrickson-intl.com](http://china.hendrickson-intl.com)

**Hendrickson Commercial Vehicle Systems India**  
Plot No. 4 & 5, Gat. No. 679/2  
Behind Hotel Gandharva  
Alandi Kuruli Road, Kuruli (Chakan)  
Taluka Khed, Pune 410501, India  
+91 2135 662600  
[india.hendrickson-intl.com](http://india.hendrickson-intl.com)

**Hendrickson Commercial Vehicle Systems UK**  
1-9 Booth Drive  
Park Farm Industrial Estate  
Wellingborough, NN8 6GR,  
England  
+44(0) 1604 493161  
[uk.hendrickson-intl.com](http://uk.hendrickson-intl.com)