

HTA[®] HENDRICKSON TRAILER AXLE[™]

- Proven performance
- Industry-standard trailer axle
- Less downtime

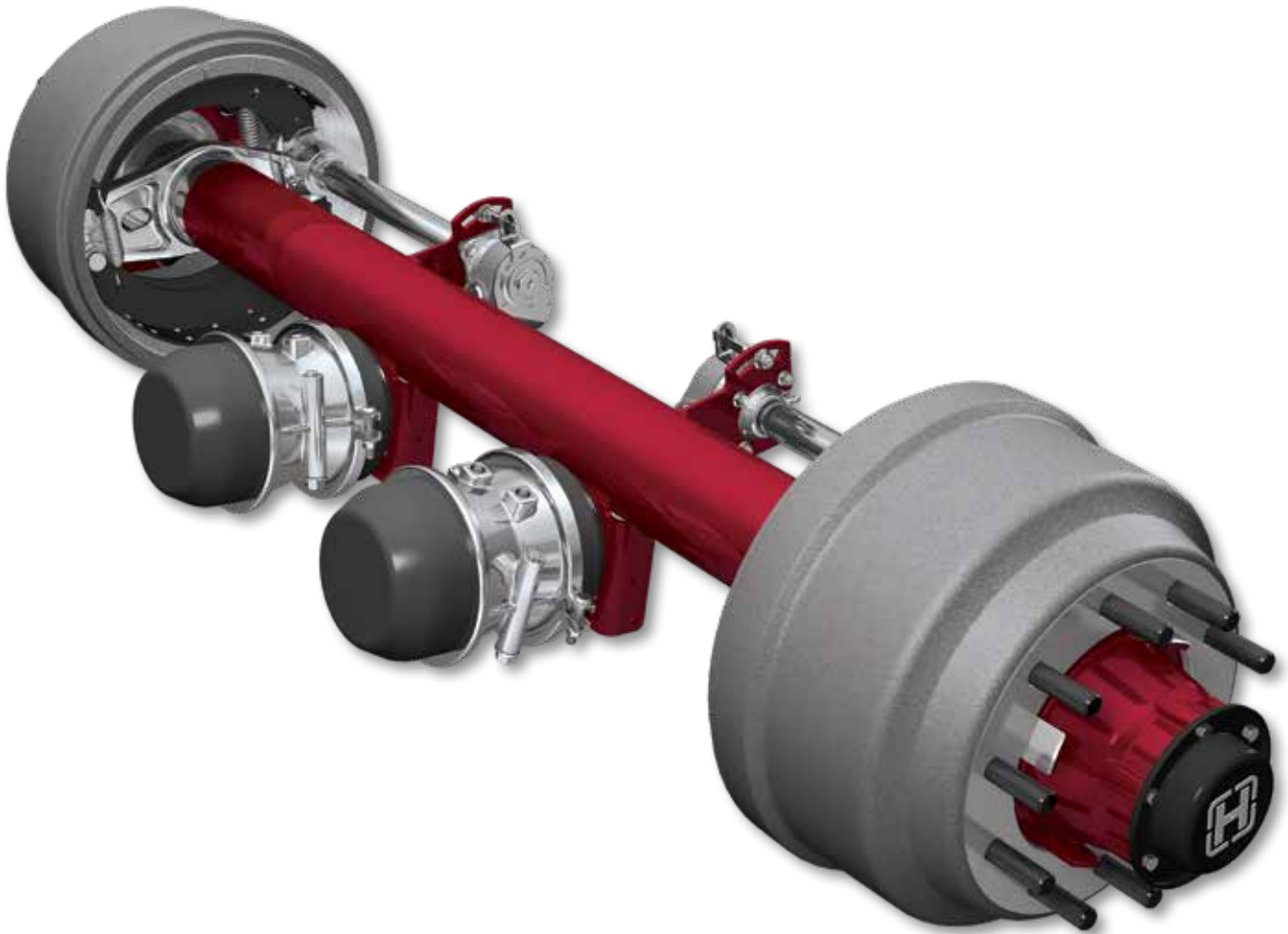

Worldwide Product Support

As a leading supplier to the global commercial vehicle market, Hendrickson boasts a wide breadth of product and application knowledge. Our sales and service teams are available to provide support – from applications advice to onsite training.

Low-Maintenance

Hendrickson's product testing and specifications provide durable, low-maintenance parts. The HTA[®] system features a robust design that has durability in mind. From heat treated spindles to hardened cam heads, journals and splines, the HTA is ready for kilometer after kilometer.

Outstanding Warranty Coverage

Hendrickson's industry-leading warranty guarantees outstanding coverage and support from a recognised name in the commercial vehicle industry and the convenience of a single source supplier.

To learn more about HTA Hendrickson Trailer Axle, call Hendrickson or visit our global websites for additional information.

 **HENDRICKSON**
The World Rides On Us[®]

HTA® HENDRICKSON TRAILER AXLE™ Features and Benefits

Brakes and RTR® Wheel-Ends

- 9t (20,000 lbs.) capacity
- 420mm x 180mm (16.5 x 7 in.) standard service – fast change shoes using Hendrickson proprietary 20K lining
- e-Coated brake shoes for protection against rust jacking
- Forged S-cams with hardened head, journals and splines
- Lightweight outboard mounted cast iron brake drums
- Cam shafts removable without removing the hub
- ABS ready
- 275mm, 11.25 in. and 335mm bolt circles

- Premium Hendrickson Gold Seal
- Hendrickson's patented axle filter and axle venting system
- Patented PRECISION240® and PRECISION320® system allows for ultra precise bearing adjustment
- HXL™ Hendrickson Extended-Life System standard with a 2-year parts and labour warranty*
- Synthetic semi-fluid grease

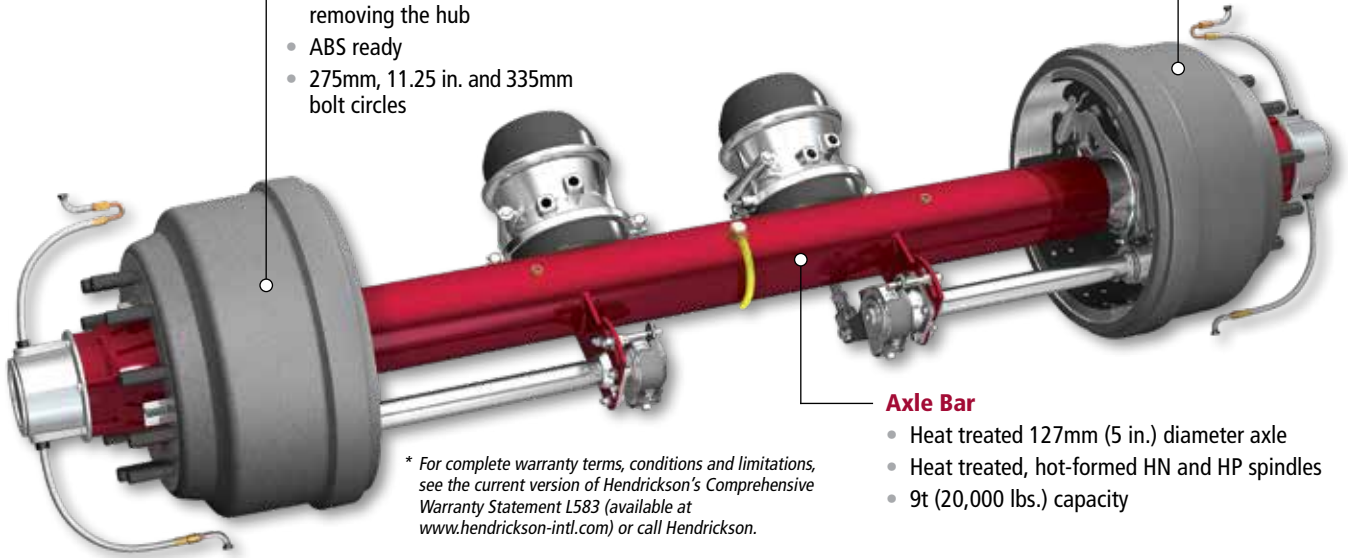

Axle Bar

- Heat treated 127mm (5 in.) diameter axle
- Heat treated, hot-formed HN and HP spindles
- 9t (20,000 lbs.) capacity

* For complete warranty terms, conditions and limitations, see the current version of Hendrickson's Comprehensive Warranty Statement L583 (available at www.hendrickson-intl.com) or call Hendrickson.

Value-Added Options

- TIREMAAX® PRO and CP tire inflation systems help maximise tyre life and maintain peak fuel mileage
- 420 x 180mm (16.5 x 7 in.) HXS® and 420 x 220mm (16.5 x 8.625 in.) HXS Hendrickson Extended Service™ brakes extend intervals between brake service
- 140 or 152mm (5.5 or 6 in.) auto slack adjusters and manual slack adjusters available
- Brake chambers in various configurations
- ABS sensor installation available
- Dura-Light Hub® and aluminum hubs available
- Dust shields available
- Spring seat installation available
- 12mm to 19mm (0.47 to 0.75 in.) axle wall thickness available

Specifications

Model	Suspension Capacities (tons)	Axle Diameter (millimeter)	Tracks (millimeter)	Base Model Weight (kilogram)
HTA	9t (20,000 lbs.)	127mm (5 in.)	1664 to 2229mm (65.5 to 87.75 in.)	234 to 384kg (516 to 847 lbs.)

All applications must comply with applicable Hendrickson specifications and must be approved by the respective vehicle manufacturer with the vehicle in its original, as-built configuration. For additional details regarding specifications, applications, capacities and service maintenance instructions, contact Hendrickson. Actual product performance may vary depending upon vehicle configuration, operation, service and other factors.

Call Hendrickson or visit our global websites for additional information.



500 Park Boulevard, Suite 450
Itasca, IL 60143-1285 USA
+1.630.874.9700

Hendrickson Commercial Vehicle Systems Europe

Hendrickson Austria GmbH
Gussstahlwerkstraße 21
A-8750 Judenburg, Austria
+43 3572 44011 400
eu.hendrickson-intl.com

Hendrickson Truck Commercial Vehicle Systems

800 South Frontage Road
Woodridge, IL 60517-4904 USA
+1.855.743.3733
+1.630.910.2800
www.hendrickson-intl.com

Hendrickson Trailer Commercial Vehicle Systems

2070 Industrial Place SE
Canton, OH 44707-2641 USA
+1.866.743.3247
+1.330.489.0045
www.hendrickson-intl.com

Hendrickson Commercial Vehicle Systems Australia

32-44 Letcon Drive
Dandenong South, Victoria,
3175 Australia
+61 3 8792 3600
aus.hendrickson-intl.com

Hendrickson Commercial Vehicle Systems China

No. 1668
North Section of Chunbo Road
East New Dist of Jinan High-Tech
Industrial Development Zone,
Jinan City, Shandong Province,
China, 250104
+86 531 8880 9055
china.hendrickson-intl.com

Hendrickson Commercial Vehicle Systems India

Plot No. 4 & 5, Gat. No. 679/2
Behind Hotel Gandharva
Alandi Kuruli Road, Kuruli (Chakan)
Taluka Khed, Pune 410501, India
+91 2135 662600
india.hendrickson-intl.com

Hendrickson Commercial Vehicle Systems UK

1-9 Booth Drive
Park Farm Industrial Estate
Wellingborough, NN8 6GR,
England
+44(0) 1604 493161
uk.hendrickson-intl.com