

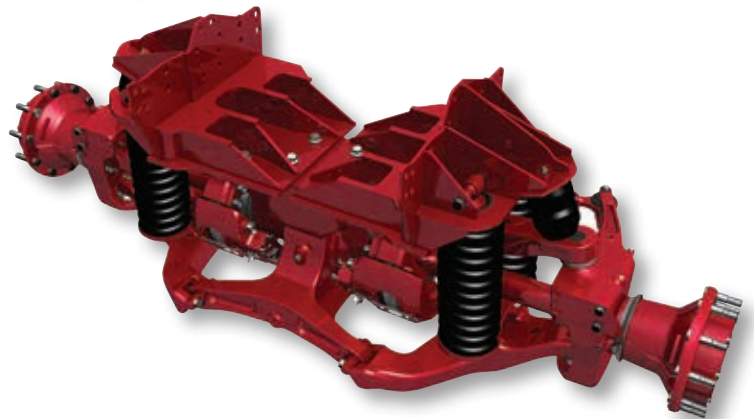

HENDRICKSON

Military Suspension Product Line

- Rugged
- Durable
- Reliable
- Versatile

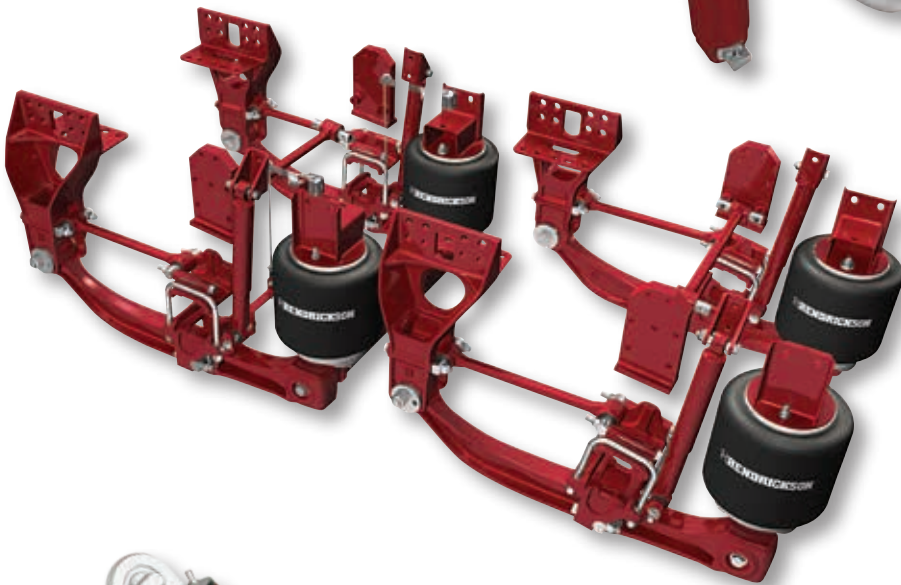
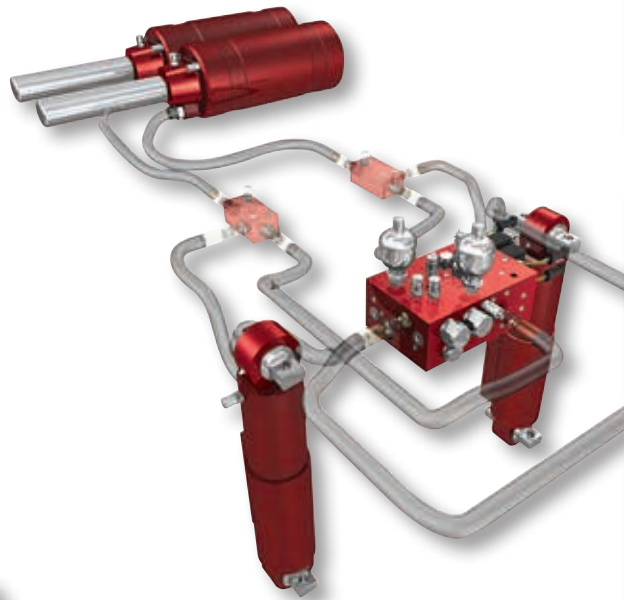

To learn more about Military Suspension Products, call 630.910.2800 or visit www.hendrickson-defense.com

H HENDRICKSON
The World Rides On Us®



Across the globe, Hendrickson is known as a proven manufacturer of reliable, heavy-duty suspensions that feature best-in-class ride and handling characteristics for severe military and commercial applications. Our legacy embodies over 100 years as the leading innovator and manufacturer of suspension systems and components for the global heavy-duty vehicle industry. Hendrickson products are designed and developed to meet stringent durability requirements and outpace the competition in regards to performance, maneuverability and quality. The robust, technologically-advanced systems designed by our engineers have proven time and time again to excel in harsh environments. In addition, our technical expertise allows us the ability to partner with customers on rapid vehicle integration projects and customization for specific applications. Over the past century, Hendrickson has built a strong reputation for reliable, durable products, and it is precisely this reputation that drives us to continually exceed the expectations of our customers.

Testing and Validation Capabilities

In 1926, Hendrickson introduced our first walking-beam suspension, a concept that is still widely used in commercial vehicle and military applications today. Since that time, we have continued to drive the industry with breakthrough suspension designs, manufacturing strength and rigorous testing and analysis techniques. Hendrickson uses advanced engineering software to model specific components, identify stress points and simulate suspension performance in different terrain and load conditions.

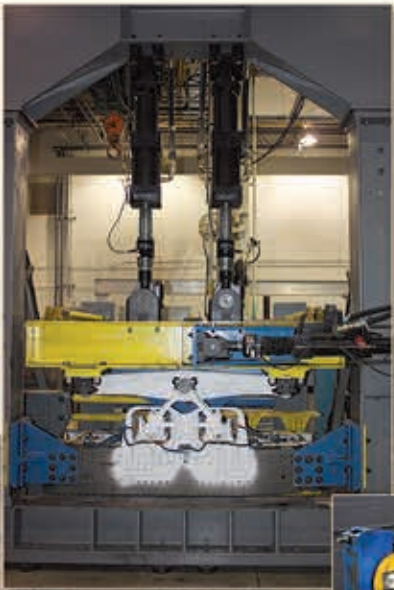
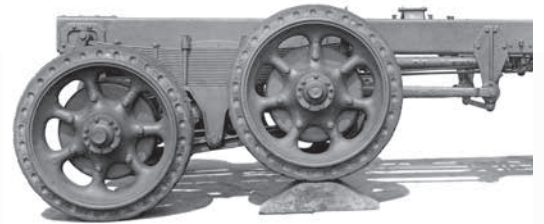

In addition, our sophisticated in-house research and development facility houses numerous test rigs designed to simulate real-world scenarios. This allows Hendrickson to achieve rapid development and increase truck manufacturers' speed-to-market with on time-sensitive government projects, while still maintaining the quality and reliability that are synonymous with Hendrickson products. Through our dedication to rigorous testing and validation, our goal remains the same — to provide the most technologically advanced and robust products available.



Independent Suspension and Axle System

The Independent Suspension combines Hendrickson's chassis integration experience, manufacturing excellence, vehicle dynamics experience and history of heavy-duty suspension design with AxleTech's expertise in high-speed planetary axle technology. The system features superior mobility, steering, ride and handling characteristics to help protect the chassis, cargo and passengers in treacherous environments. Available as a production option for new military vehicles or as an upgrade to existing vehicles in theater, the independent suspension and axle system offers advanced technology that is proven to thrive under challenging conditions.

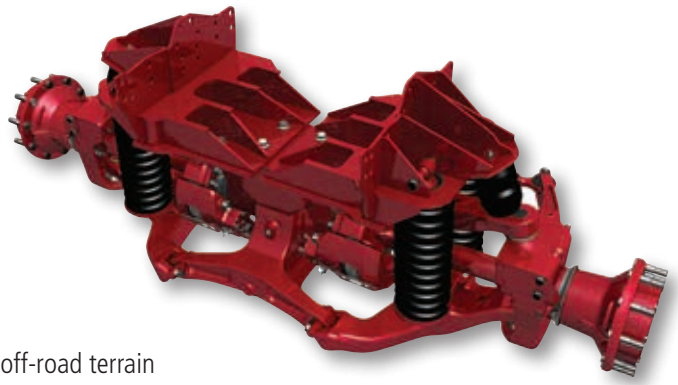

- Superior mobility and maneuverability to help maintain traction in rugged, off-road terrain
- Modular design and multiple premium options allow for customization of ride quality, stability and handling characteristics
- Capable of mating with Hendrickson's HHP™ hydro-pneumatic suspension for unparalleled ride quality, maneuverability and performance
- Highly-engineered and validated sub-frame for field retrofits offers ease of installation while providing the durability required in severe environments
- Advanced shocks and coil springs designed to offer optimal ride and vehicle performance with ease of serviceability and minimal down time
- Axle capacities ranging from 6,000 to 29,000 lbs. (2.7 to 13.2 t)

HHP™ System Hydro-Pneumatic™ Suspension System

The patented technology in Hendrickson's HHP™ Hydro-Pneumatic™ Suspension provides severe off-road vehicles with superior ride quality, handling, stability and durability with low maintenance requirements. The use of hydraulic spring cylinders combined with advanced hydraulic piston accumulators reduces vibration and harshness to the chassis and body equipment, providing a smooth ride and helping extend the life of the vehicle. The HHP system has proven to provide premium performance and rugged durability in a variety of demanding military applications.

- Hydraulic valves provide controlled, load-dependent damping for superior ride quality in demanding load conditions
- Cross-plumbing between spring cylinders provides high stability and handling characteristics to accommodate uneven terrain, NATO double lane changes and evasive maneuvers
- Advanced triple chamber piston accumulators provide a low spring rate regardless of load conditions, and equalize the load to help provide continuous tire contact with the ground for increased traction
- System provides raising and lowering capabilities and the ability to achieve multiple ride heights
- Optional blocking system automatically locks the ride height in situations where movement of the vehicle platform is not desired, such as loading, unloading, towing or satellite communications
- Power only used to level vehicle due to changes in load; no power / fuel consumption while vehicle is in motion due to closed system
- Adaptable to multiple axle combinations and load range requirements

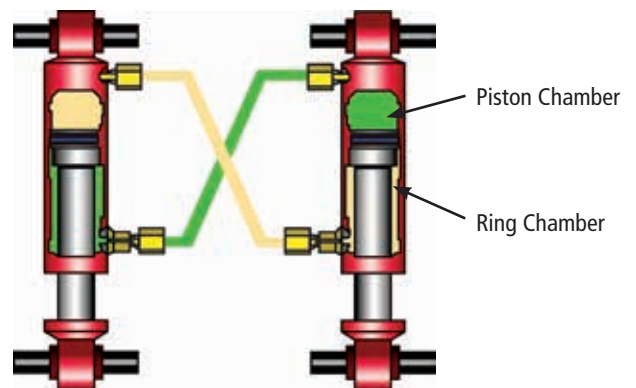
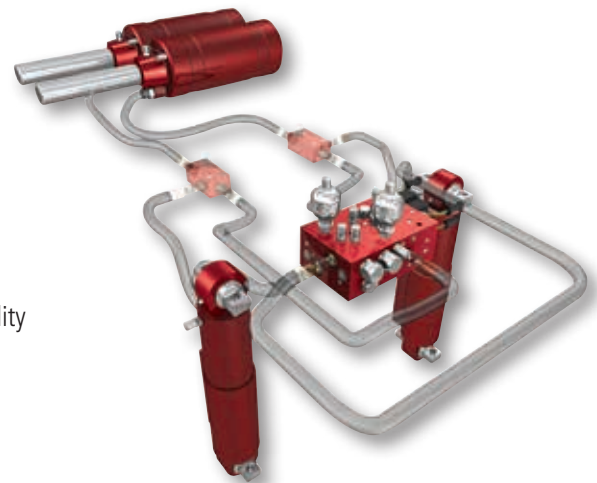

Cross Plumbing between Spring Cylinders

HPAS™ High-Performance Air Suspension

Hendrickson's HPAS™ is designed for flexibility and performance for today's economically minded military customers. The HPAS replaces traditional coil springs, air bags and damper technology while increasing performance in to one package. Our comprehensive offering includes air struts and a customizable ride height control system including manual or remote control. The HPAS can reduce suspension weight by up to 50 percent over systems with conventional coil springs and dampers, while providing a 60 percent packaging OD reduction over traditional air struts and air bags. The reduced packaging size allows for suspension resets for increased capacity, large tires and increased protection.

- Complete ride height with spring damper control system
- Reduced packaging size
- Debris and environmental resistance
- Improves vehicle handling
- Increases roll stability
- Easy vehicle retrofit packages
- Provides raising and lowering capabilities
- Multiple ride height capability
- Adaptable to multiple axle combinations
- Adaptable to multiple load range requirements, increasing payload capability while maintaining ride quality at all load ranges



Leaf Spring Capabilities

With experience, expertise and vision, Hendrickson continues to redefine leaf spring and suspension engineering for military and commercial vehicle applications around the world. Hendrickson's innovations in exclusive manufacturing and materials technology have revolutionized leaf spring performance. This proprietary technology allowed Hendrickson engineers to produce more efficient springs that reduce weight and improve ride performance and durability.

Parabolic Taper-leaf – Front

- Hendrickson is the leading manufacturer of parabolic taper-leaf springs, custom designed for a variety of applications. The parabolic taper spring is constructed using our proprietary process and materials.

Parabolic Taper-leaf – Rear

- Hendrickson has revolutionized the design of rear heavy-section parabolic springs for various military and vocational applications.

Multi-leaf

- Hendrickson designs and produces multi-leaf springs for a variety of demanding applications. Rugged yet efficient, the multi-leaf is subject to all of Hendrickson's stringent design and quality assurance standards.



RT™ Durable Steel Leaf Spring Suspension

RT™ is a robust steel spring suspension with a legacy of over 80 years of reliability in some of the most severe applications. Hendrickson-designed springs provide a consistent spring rate for longer life, as the equalizing beams distribute load equally between both axles for improved traction. The suspension provides exceptional durability, stability and traction, making RT well-suited for many military applications.

- Genuine Hendrickson springs are made from high-strength steel and are heat-treated and shot-peened for exceptional fatigue life
- Equalizing beams utilize a central pivot point to help keep tire contact with the ground for improved traction
- Suspension design provides a low center of gravity for increased stability
- Up to 15 inches (381 mm) of diagonal articulation for outstanding traction and mobility
- Rugged beam-to-axle connection extends bushing life and allows easy axle alignment
- Optional shock kit available for improved ride
- Tandem capacities up to 65,000 pounds (29.5 t)

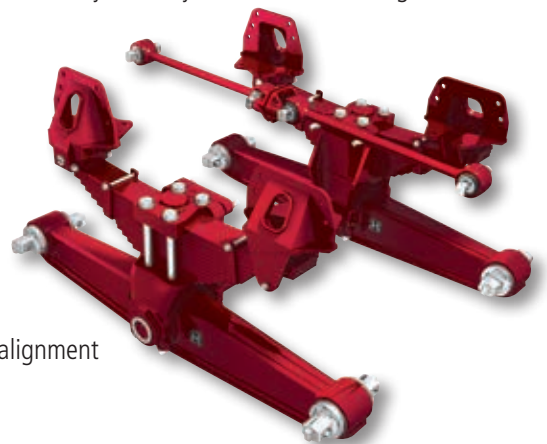

PRIMAAX® EX Severe-duty Vocational Air or Coil Spring Suspension

With its rugged, weight-efficient design, PRIMAAX® EX is a severe-duty vocational air or coil suspension that delivers advanced suspension technology for the rigorous demands of severe applications. PRIMAAX EX offers a premium ride and optimal performance by adjusting to both the load and road conditions, while demonstrating outstanding articulation for superior off-road mobility. The system features a robust structural design with optimized suspension geometry for superior stability, handling and ride quality.

- Optimized geometry contributes to high roll stiffness characteristics
- Axle connection and torque rods help reduce torsional axle stress and driveline vibration
- Option to use large-volume, low frequency air springs or heavy-duty coil springs to help smooth the ride in rugged off-road conditions
- Up to 12.5 inches (318 mm) of diagonal wheel articulation for superior mobility
- Capacities of 23,000 and 26,000 pounds (10.4, 11.8 t) single-axle, 46,000 and 52,000 pounds (20.9, 23.6 t) tandem-axle and 69,000 and 78,000 pounds (31.3, 35.4 t) tridem-axle

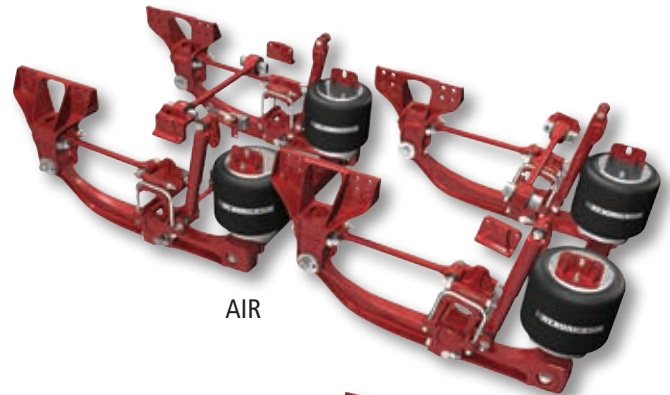

AIR

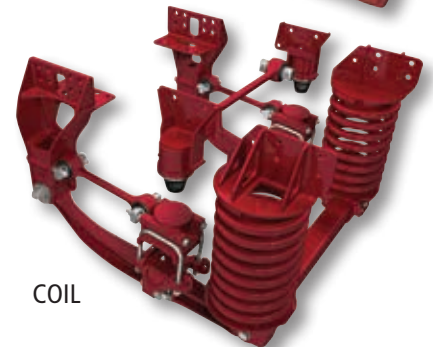

COIL

HAULMAAX® / HN® / ULTIMAAX™ Heavy-duty Rubber Suspensions

Providing an ideal combination of stability, ride quality, light weight and articulation, HAULMAAX®, HN® and ULTIMAAX™ heavy-duty rubber suspensions deliver the exceptional performance required to meet the challenges of various demanding military and vocational applications. Diagonally-mounted rubber bolster springs act in compression and shear to deliver superior ride quality by dissipating road shock, while auxiliary springs provide outstanding stability in rugged conditions.

- Auxiliary springs offer tremendous roll stability for vehicles traveling in harsh environments and are adjustable to help improve ride quality for different body and equipment configurations
- Up to 17 inches (432 mm) of diagonal articulation help keep the axle in traction for greater off-road mobility
- Reduced maintenance with fewer bushings and no lubrication requirements
- Systems can be tailored to meet the specific requirements for frame width, ride height and axle spacing for unique vehicle applications
- HAULMAAX available in tandem capacities of 40,000 and 46,000 pounds (18.1, 20.9 t), HN available in tandem capacities of 40,000, 46,000 and 52,000 pounds (18.1, 20.9, 23.6 t) and ULTIMAAX available in tandem capacities of 46,000, 52,000 and 60,000 pounds (20.9, 23.6, 26.7 t)

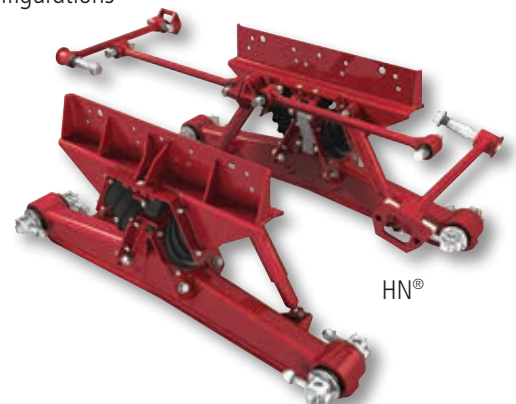

HN®

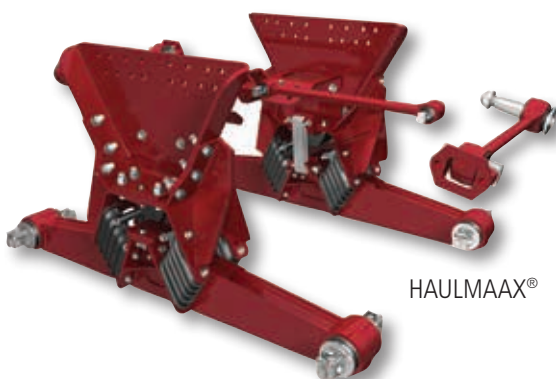

HAULMAAX®

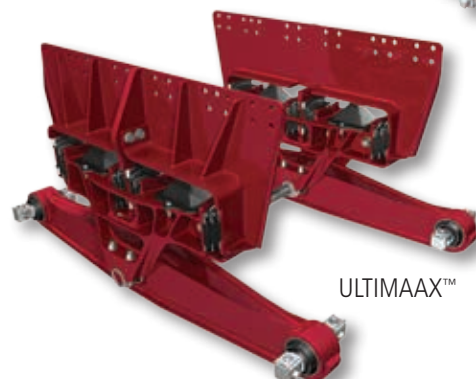

ULTIMAAX™

Hendrickson's products, while often unseen, are involved in many areas of life — from the trucks that deliver groceries and other goods to retail outlets, to construction vehicles that carry goods to build homes and improve our country's infrastructure. Hendrickson is also just as involved with supplying product for robust military vehicles that support and protect our armed forces around the world.

Hendrickson has supported the military for over 80 years through various programs including the M915 and M916 tractors. For more than four decades, we have continued to expand our involvement with the military through numerous vehicle programs including the HMTT, HETS, PLS, MVT, MTRV, LVS and MRAP vehicles.

Through our experience and our strengths in design and development, Hendrickson clearly understands that each military application is unique, and thus requires a unique solution. Our involvement early in the process enables Hendrickson to deliver reliable, durable and innovative suspension systems to help support and protect our troops, as they serve and protect our country.

At Hendrickson, INNOVATION NEVER RESTS...



Sustaining Member



Hendrickson Genuine Parts are the same quality components installed in Hendrickson original equipment suspensions — consisting of the same design, construction, performance and durability. There's only one way to maintain and protect your suspension's original performance. Ask for the name that is synonymous with the finest manufactured suspensions in the world.

Call Hendrickson at **630.910.2800** for additional information.



TRUCK COMMERCIAL VEHICLE SYSTEMS
800 South Frontage Road
Woodridge, IL 60517-4904 USA
630.910.2800
Fax 630.910.2899

www.hendrickson-defense.com