

Army Heavy Dump Truck Suspension

- MAAximize durability
- MAAximize driver comfort
- MAAximize performance

Across the globe, Hendrickson is known as a proven manufacturer of reliable, heavy-duty suspensions that feature best-in-class ride and handling characteristics for severe military and commercial applications.



To learn more about Military Suspension Products, call 630.910.2800 or visit www.hendrickson-defense.com

LEAF SPRING Capabilities

With experience, expertise and vision, Hendrickson continues to redefine leaf spring and suspension engineering for military and commercial vehicle applications around the world. Hendrickson's innovations in exclusive manufacturing and materials technology have revolutionized leaf spring performance. This proprietary technology has allowed Hendrickson engineers to produce more efficient springs that reduce weight and improve ride performance and durability.

Parabolic Taper-leaf – Front

- Hendrickson is the leading manufacturer of parabolic taper-leaf springs, custom designed for a variety of applications. The parabolic taper spring is constructed using our proprietary process and materials.

Multi-leaf

- Hendrickson designs and produces multi-leaf springs for a variety of demanding applications. Rugged yet efficient, the multi-leaf is subject to all of Hendrickson's stringent design and quality assurance standards.

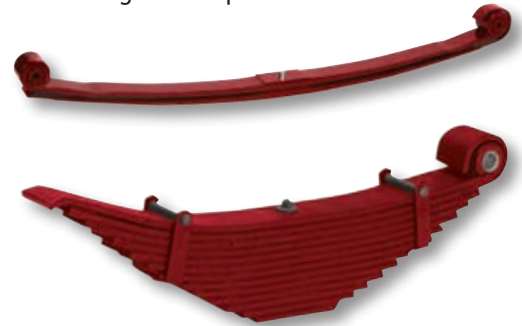

ULTIMAAX™ Advanced Severe-Duty Rubber Suspension

Through development and testing in Hendrickson's state-of-the-art lab and demanding high-articulation events on challenging proving grounds courses, the ULTIMAAX™ system has withstood extensive test environments. In addition, early versions of the ULTIMAAX system have been field proven to provide extreme durability in harsh terrain. Aside from providing a reliable system for maximum uptime, ULTIMAAX is a low maintenance system that contributes to reduced life cycle costs and less down time in the following ways:

- Superior ride results in reduced road shock and vibration to the vehicle, which contributes to longer service life of the cab, chassis and body equipment
- No lubrication requirements
- Progressive rate springs provide long service life and are easy to replace
- Bar pin end bushings designed to extend service life and reduce re-bush time
- Hendrickson parts and service available at thousands of locations worldwide
- Comprehensive technical support and training available

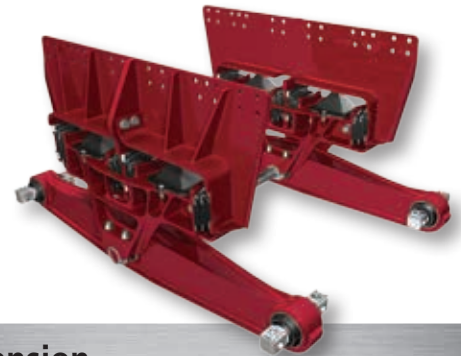

PRIMAAX® EX Severe-duty Vocational Air or Coil Spring Suspension

With its rugged, weight-efficient design, PRIMAAX® EX is a severe-duty vocational air or coil suspension that delivers advanced suspension technology for the rigorous demands of severe applications. PRIMAAX EX offers a premium ride and optimal performance by adjusting to both the load and road conditions, while demonstrating outstanding articulation for superior off-road mobility. The system features a robust structural design with optimized suspension geometry for superior stability, handling and ride quality.

- Optimized geometry contributes to high roll stiffness characteristics
- Axle connection and torque rods help reduce torsional axle stress and driveline vibration
- Option to use large-volume, low frequency air springs or heavy-duty coil springs to help smooth the ride in rugged off-road conditions
- Up to 12.5 inches (318 mm) of diagonal wheel articulation for superior mobility
- Capacities of 23,000 and 26,000 pounds (10.4, 11.8 t) single-axle, 46,000 and 52,000 pounds (20.9, 23.6 t) tandem-axle and 69,000 and 78,000 pounds (31.3, 35.4 t) tridem-axle

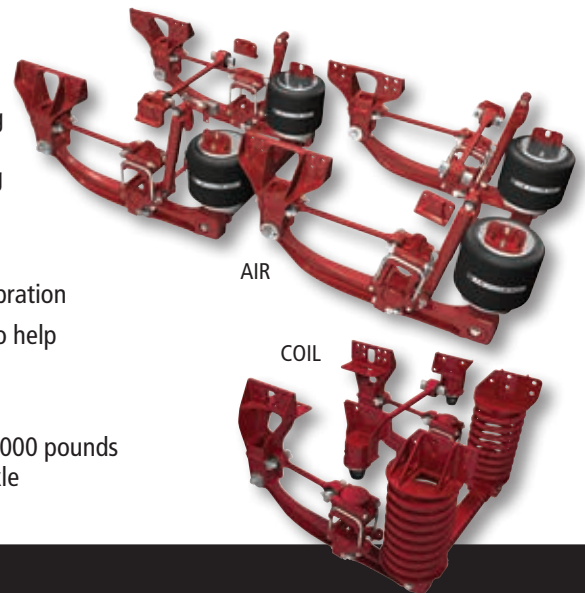

Call Hendrickson at **630.910.2800** for additional information.



TRUCK COMMERCIAL VEHICLE SYSTEMS
800 South Frontage Road
Woodridge, IL 60517-4904 USA
630.910.2800
Fax 630.910.2899

www.hendrickson-defense.com