

- Extreme durability
- Premium ride quality
- Low life cycle costs
- Lighter than mechanical suspensions in the same class

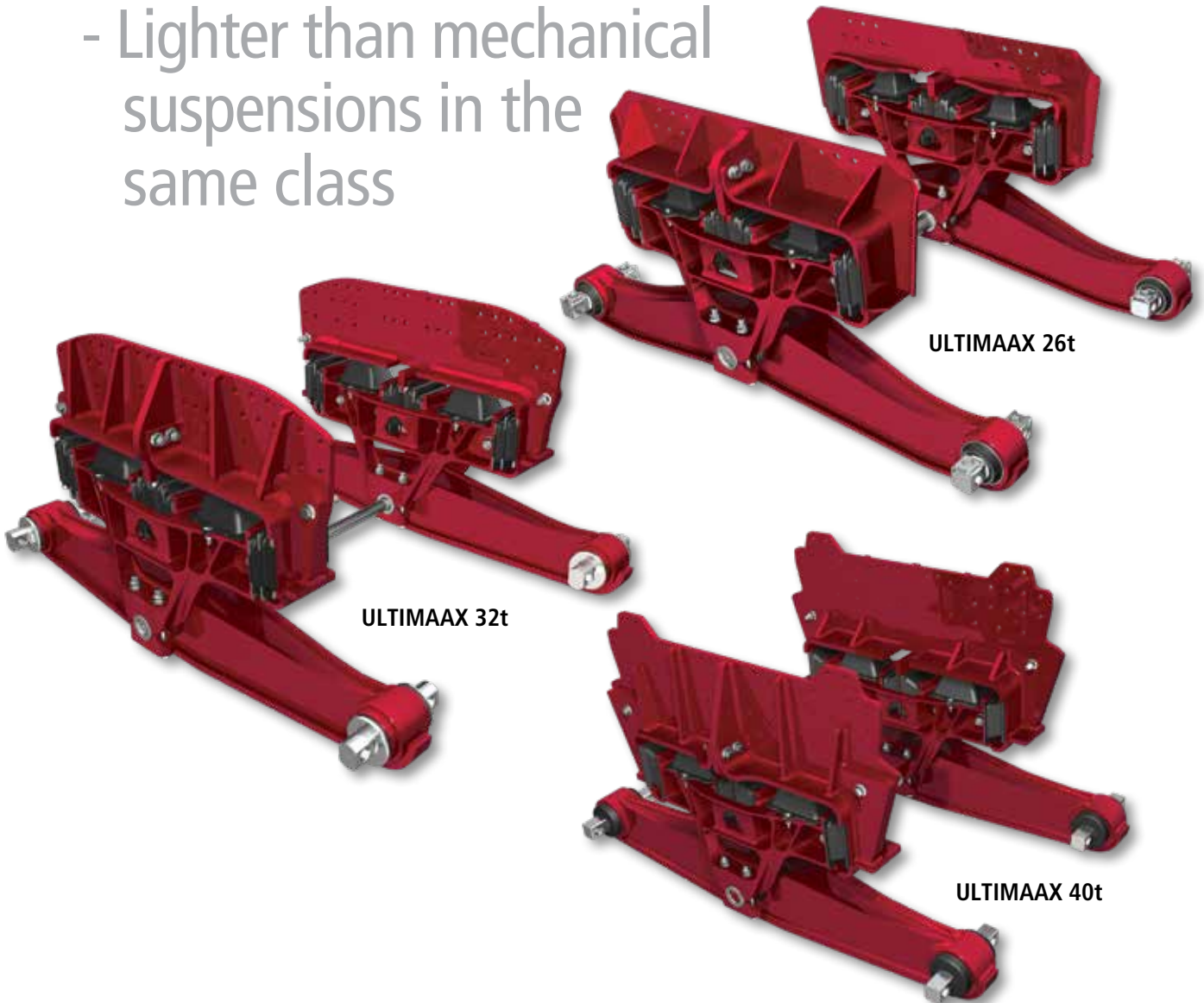

ULTIMAAX 26t

ULTIMAAX 32t

ULTIMAAX 40t



Hendrickson's ULTIMAAX[®] advanced severe-duty rubber suspension, balances outstanding durability, ride quality, mobility and stability. The efficient design is engineered to reduce complexity for truck manufacturers in supply chain, assembly and warranty management as well as to help lower life cycle costs for fleets in daily operation. ULTIMAAX is designed and recommended for severe-duty truck applications such as tippers, mining and refuse trucks.

To learn more about ULTIMAAX, call Hendrickson or visit our global websites for additional information.

ULTIMAAX® Features and Benefits

Increase Durability

- Demanding job-site conditions
- Designed and tested to provide extreme durability in harsh terrain

Lower Life Cycle Costs

- Higher payload — for increased productivity
- Reduced maintenance — no lubrication points

Improve Driveability

- Premium ride quality in laden and unladen conditions
- Progressive roll stability — improves road contact during cornering manoeuvres
- Excellent articulation and traction — up to 400mm (laden)



ULTIMAAX 26t

- Continuous operating loads up to 29t
- Up to 250kg lighter than comparable mechanical suspension

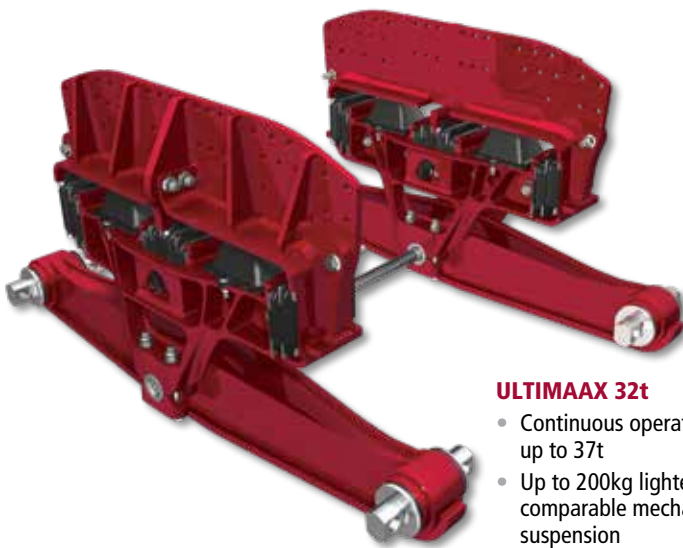

ULTIMAAX 32t

- Continuous operating loads up to 37t
- Up to 200kg lighter than comparable mechanical suspension

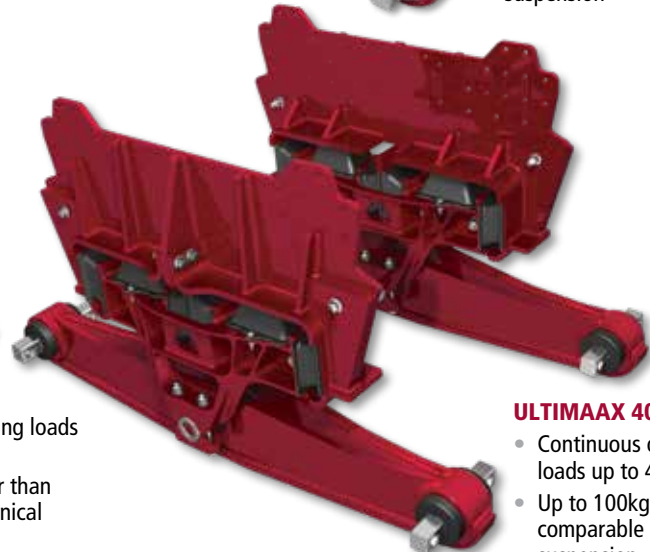

ULTIMAAX 40t

- Continuous operating loads up to 48t
- Up to 100kg lighter than comparable mechanical suspension

ULTIMAAX Specifications

	26t	32t	40t
Suspension Rating	26 to 29t	32 to 37t	40 to 48t
Ride Heights¹	200 to 300mm	250 to 350mm	250 to 350mm
Axle Spacing¹	1,350 - 1,500mm	1,350 - 1,500mm	1,400 - 1,500mm

1. For different ride heights or axle spacing options, contact Hendrickson for further information.

All applications must comply with applicable Hendrickson specifications and must be approved by the respective vehicle manufacturer with the vehicle in its original as-built configuration. Contact Hendrickson for additional details regarding specifications, applications, capacities, and operation, service and maintenance instructions.

For additional details regarding specifications, applications, capacities, and operating, service and maintenance instructions, refer to applicable Hendrickson technical literature (available at www.hendrickson-intl.com) or contact Hendrickson.

Shock absorbers are required in tractor and logging applications. Ride and traction may be improved in other applications with shock absorbers. Ride performance can be subjective and may be dependent on many factors beyond the suspension design such as cab suspension, road conditions, body/auxiliary equipment, frame specifications, etc. Contact Hendrickson or your truck manufacturer/dealer for further information.

Actual product performance may vary depending upon vehicle configuration, operation, service and other factors.



This product is covered by at least one or more U.S. and/or foreign patents and/or pending U.S. foreign patent applications.

Actual product performance may vary depending upon vehicle configuration, operation, service and other factors.

All applications must comply with applicable Hendrickson specifications and must be approved by the respective vehicle manufacturer with the vehicle in its original, as-built configuration. Contact Hendrickson for additional details regarding specifications, applications, capacities, and operation, service and maintenance instructions.

Call Hendrickson or visit our global websites for additional information.



HENDRICKSON TÜRKİYE
A.O.S.B 10016 Sokak, No:8
Çiğli - İzmir, Türkiye
Tel: +90.232.328.22.80
Faks: +90.232.328.02.80

www.eu.hendrickson-intl.com

45745-591 Rev A 12-23

© 2023 Hendrickson USA, L.L.C. All Rights Reserved. All trademarks shown are owned by Hendrickson USA, L.L.C., or one of its affiliates, in one or more countries. Information contained in this literature was accurate at the time of publication. Product changes may have been made after the copyright date that are not reflected.